



LISTINO  
**2025**

## **Le nostre certificazioni / Our certifications:**

I prodotti inseriti nel presente catalogo sono progettati e costruiti a regola d'arte in materia di sicurezza e nel rispetto dei requisiti delle seguenti norme e direttive / The products included in this catalogue are designed and built following all safety regulations and in accordance with the requirements of the following norms and directives:

**2014/30/UE:** Direttiva Compatibilità elettromagnetica / electromagnetic compatibility directive.

**2016/426/UE:** Regolamento sicurezza impiego gas combustibile / regulation appliances burning gaseous fuels.

**2014/35/UE:** Direttiva bassa tensione / Low voltage directive.

**1935/2004/CE 2023/2006/CE:** Regolamento riguardante materiali e oggetti destinati a venire a contatto con i prodotti alimentari (MOCA) / Regulation on materials and articles intended to come into contact with food.

**2011/65/UE:** Restrizione dell'uso di sostanze pericolose nelle apparecchiature elettriche ed elettroniche I RoHS / Restriction of the use of certain hazardous substances in electrical and electronic equipment I RoHS.

**2012/19/UE:** Rifiuti di apparecchiature elettriche ed elettroniche I RAEE / Waste on electric and electronic equipment I RAEE.

Le apparecchiature sono inoltre conformi ai seguenti standard:

**EN 60335-1 EN 60335-2:** Apparecchiature elettriche / electric appliances

**EN 203:** Apparecchiature a gas / gas appliances

**CASTA SRL** è in possesso della certificazione del sistema gestione qualità **ISO 9001 : 2015** / **CASTA SRL** has the quality management system certification **ISO 9001 : 2015**



# INDICE - INDEX - INHALT - INDEX - INDICE

Listino prezzi 2023 - Price list 2023 - Preisliste 2023 - Tarif 2023 - Lista de precios 2023

Pag.

Cucine semi-professionali 700 - Semi-professional ranges 700 - Semi-Professionelle Gasherde 700 - Cuisinières semi-professionnelles 700 - Cocinas semi-profesionales 700

**FAST** 1

**SMART** 4

**FRIGGITRICI PER PASTICCERIA - PASTRY FRYERS - FRITEUSES POUR PÂTISSERIE - FREIDORAS PARA PASTELERÍA** 7

Cottura modulare 700 - Modular cooking line 700 - Modul Kochlinie 700 -  
Ligne de cuisson modulaire 700 - Linea de cocción modular 700

**PRIME700** 11

**EASY 700** 19

Cucine - Ranges - Herde - Cuisinières - Cocinas	16
Scaldapatate - Chip scuttle - Kartoffelwärmer - Chauffe frites - Calienta patatas	19
Friggitrici - Fryers - Fritteusen - Friteuses - Freidoras	20
Cuocipasta - Pasta-cookers - Nudelkocher - Cuisèur à pâtes- Cuece-pastas	22
Bagnomaria - Bains-marie - Wasserbäder - Bains-marie - Baños María	24
Griglie a pietra lavica - Lavastone grill - Lavastein-grill - Grilles pierre volcanique - Parrillas de piedra volcanica	25
Fry top - Griddle plates - Grillplatten - Fry-top - Fry-top	26
Elementi neutri - Neutral units - Arbeitselemente - Elements neutres - Muebles neutros	30
Accessori - Accessories - Zubehöre - Accessoires - Accesorios	31

**LADY 700** 33

Cucine - Ranges - Herde - Cuisinières - Cocinas	34
Scaldapatate - Chip scuttle - Kartoffelwärmer - Chauffe frites - Calienta patatas	42
Friggitrici - Fryers - Fritteusen - Friteuses - Freidoras	43
Cuocipasta - Pasta-cookers - Nudelkocher - Cuisèur à pâtes- Cuece-pastas	46
Bagnomaria - Bains-marie - Wasserbäder - Bains-marie - Baños María	50
Vaporiera Dim Sum - Dim Sum steamer - Dim Sum Dampfgerar - Cuiseur vapeur pour Dim Sum - Vaporera Dim Sum	51
Griglie a pietra lavica - Lavastone grill - Lavastein-grill - Grilles pierre volcanique - Parrillas de piedra volcanica	52
Fry top - Griddle plates - Grillplatten - Fry-top - Fry-top	53
Elementi neutri - Neutral units - Arbeitselemente - Elements neutres - Muebles neutros	57
Pentole - Boiling pans - Kochkessel - Marmites - Marmitas	58
Brasiere - Tilting bratt pans - Kippbratpfannen - Sauteuses basculantes - Sartenes basculantes	59
Accessori - Accessories - Zubehöre - Accessoires - Accesorios	60

# INDICE - INDEX - INHALT - INDEX - INDICE

Listino prezzi 2023 - Price list 2023 - Preisliste 2023 - Tarif 2023 - Lista de precios 2023

Pag.

## Cottura modulare 900 - Modular cooking line 900 - Modul Kochlinie 900 - Ligne de cuisson modulaire 900 - Linea de cocción modular 900

### LADYQ900 61

Cucine - Ranges - Herde - Cuisinières - Cocinas	62
Scaldapatate - Chip scuttle - Kartoffelwärmer - Chauffe frites - Calienta patatas	75
Friggitrici - Fryers - Fritteusen - Friteuses - Freidoras	76
Cuocipasta - Pasta-cookers - Nudelkocher - Cuisèur à pâtes- Cuece-pastas	78
Bagnomaria - Bains-marie - Wasserbäder - Bains-marie - Baños María	82
Vaporiera Dim Sum - Dim Sum steamer - Dim Sum Dampfgarer - Cuiseur vapeur pour Dim Sum - Vaporera Dim Sum	83
Griglie a pietra lavica - Lavastone grill - Lavastein-grill - Grilles pierre volcanique - Parrillas de piedra volcanica	84
Fry top - Griddle plates - Grillplatten - Fry-top - Fry-top	85
Elementi neutri - Neutral units - Arbeitselemente - Elements neutres - Muebles neutros	89
Pentole - Boiling pans - Kochkessel - Marmites - Marmitas	90
Brasiere - Tilting bratt pans - Kippbratpfannen - Sauteuses basculantes - Sartenes basculantes	92
Accessori - Accessories - Zubehöre - Accessoires - Accesorios	93

### AÏSHA - AÏSHA - AÏSHA - AÏSHA- AÏSHA 95

### DROP-IN ELEMENTS - EINBAUELEMENTE - ELEMENTS ENCASTRABLES - ELEMENTOS ENCASTRABLES 97

### JUST COOK 105

### COTTURA ETNICA - ETHNIC COOKING LINE - ETHNISCH KOCHLINIE - LIGNE DE CUISSON ETHNIQUE - Linea de cocción étnico

Cucine wok - Wok stoves - Wok Herde - Cuisinières wok - Cocinas wok	107
Piastra per cottura giapponese - Japanese hot plate - Japanische bratplatte - Plaque japonais - Placas japonesas	159
Yakitori gas - Gas yakitori - Gas yakitori - Yakitori a gaz - Yakitori a gas	177

### LINEA FASTFOOD - FASTFOOD LINE - FASTFOOD-LINIE - LIGNE FAST FOOD - LINEA FASTFOOD

Piastra fry-top cuocipiadina e salsiccia - Fry-top for piadina and sausages - Grillplatte für piadina und Hackfleischwurst - Plaque fry-top pour cuisson de piadina et saucisse - Plancha fry-top para piadina e salchicha	179
--	-----

### BROILYGRILL - BROILYGRILL - BROILYGRILL - BROILYGRILL - BROILYGRILL 185

BroilyGrill Gas - Gas BroilyGrill - Gas BroilyGrill - BroilyGrill Gaz - BroilyGrill a Gas	
BroilyGrill Elettrica - Electric BroilyGrill - Elektro BroilyGrill - BroilyGrill Électrique - BroilyGrill Eléctricas	

### TEPP-ICE 195

### TEPP-TWIN 197

### FLEXIBLE COOKING 201



**fast** **smart**



**CUCINE GAS SEMI-PROFESSIONALI**

 SEMI-PROFESSIONAL GAS RANGES - SEMI-PROFESSIONELLE GASHERDE -  
 CUISINIÈRES GAZ SEMI-PROFESSIONNELLES - COCINAS GAS SEMI  
 PROFESIONALES

**FAST**

















	Model	 (A x B x C) mm	kW	Burners	Oven	€
senza fiamma pilota - without pilot flame - ohne Pilotflamme - sans veilleuse flamme - sin llama piloto						
<b>GRIGLIA IN GHISA - CAST IRON GRID - GUSSEISENGITTER - GRILLE EN FONTE - PARILLA EN HIERRO FUNDIDO</b>						
	<b>F7/KUG4BA</b>	800x700x850h	19,0			<b>2.027,00</b>
	<b>F7/KUG6BA</b>	1.200x700x850h	28,5			<b>2.670,00</b>
	<b>F7/KUG4LO</b>	800x700x850h	26,9		 GN 2/1 mm.685x550x310h	<b>2.999,00</b>
	<b>F7/KUG4LE</b>	800x700x850h	19,0 5,48		 400V3N~ 50/60Hz GN 2/1 mm.685x550x310h	<b>3.190,00</b>
	<b>F7/KUG6LN</b>	1.200x700x850h	36,4		 GN 2/1 mm.685x550x310h	<b>3.876,00</b>
	<b>F7/KUG6LE</b>	1.200x700x850h	28,5 5,48		 400V3N~ 50/60Hz GN 2/1 mm.685x550x310h	<b>4.068,00</b>

Accessori in dotazione nr.1 griglia interna forno - Accessories included nr.1 internal grid for oven - Zubehöre inbegriffen nr.1 Rost für Ofen - Accessoires inclus nr.1 grille pour four - Accesorios incluidos nr.1 parilla para horno

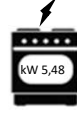
<b>ACCESSORI - ACCESSORIES - ZUBEHÖRE - ACCESSOIRES - ACCESORIOS</b>						
	<b>21/GX2/1</b>	530x650			Griglia cromata interna forno - Chrome plated grid for oven - Verchromte Rost für Ofen - Grille chromée pour four - Parilla cromada para horno	<b>75,00</b>

**CUCINE GAS SEMI-PROFESSIONALI**

 SEMI-PROFESSIONAL GAS RANGES - SEMI-PROFESSIONELLE GASHERDE -  
 CUISINIÈRES GAZ SEMI-PROFESSIONNELLES - COCINAS GAS SEMI  
 PROFESIONALES

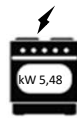



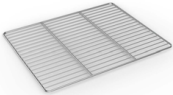

















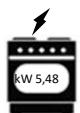

	Model	 (A x B x C) mm	kW	Burners	Oven	€
senza fiamma pilota - without pilot flame - ohne Pilotflamme - sans veilleuse flamme - sin llama piloto						
<b>GRIGLIA FILO - WIRE GRID - DRAHTGITTER - GRILLE EN FIL - PARILLA EN REDONDOS</b>						
	<b>F7/FUG4BA</b>	800x700x850h	19,0			<b>1.808,00</b>
	<b>F7/FUG6BA</b>	1.200x700x850h	28,5			<b>2.356,00</b>
	<b>F7/FUG4LO</b>	800x700x850h	26,9		 GN 2/1 mm.685x550x310h	<b>2.752,00</b>
	<b>F7/FUG4LE</b>	800x700x850h	19,0 5,48		 400V3N~ 50/60Hz GN 2/1 mm.685x550x310h	<b>2.939,00</b>
	<b>F7/FUG6LN</b>	1.200x700x850h	36,4		 GN 2/1 mm.685x550x310h	<b>3.527,00</b>
	<b>F7/FUG6LE</b>	1.200x700x850h	28,5 5,48		 400V3N~ 50/60Hz GN 2/1 mm.685x550x310h	<b>3.712,00</b>

Accessori in dotazione nr.1 griglia interna forno - Accessories included nr.1 internal grid for oven - Zubehöre inbegriffen nr.1 Rost für Ofen - Accessoires inclus nr.1 grille pour four - Accesorios incluidos nr.1 parilla para horno

<b>ACCESSORI - ACCESSORIES - ZUBEHÖRE - ACCESSOIRES - ACCESORIOS</b>				
	<b>21/GX2/1</b>	530x650	Griglia cromata interna forno - Chrome plated grid for oven - Verchromte Rost für Ofen - Grille chromée pour four - Parilla cromada para horno	<b>75,00</b>

**CUCINE GAS SEMI-PROFESSIONALI**

 SEMI-PROFESSIONAL GAS RANGES - SEMI-PROFESSIONELLE GASHERDE -  
 CUISINIÈRES GAZ SEMI-PROFESSIONNELLES - COCINAS GAS SEMI  
 PROFESIONALES

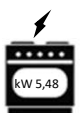
	Model	 (A x B x C) mm	kW	Burners	Oven	€
senza fiamma pilota - without pilot flame - ohne Pilotflamme - sans veilleuse flamme - sin llama piloto						
GRIGLIA FILO - WIRE GRID - DRAHTGITTER - GRILLE EN FIL - PARILLA EN REDONDOS						
	S7/FUG4BA	800x700x850h	 15,4			1.838,00
	S7/FUG6BA	1.200x700x850h	 23,1			2.389,00
	S7/FUG4LO	800x700x850h	 23,3		 GN 2/1 mm.685x550x310h	2.787,00
	S7/FUG4LE	800x700x850h	 15,4  5,48		 400V3N~ 50/60Hz GN 2/1 mm.685x550x310h	2.975,00
	S7/FUG6LN	1.200x700x850h	 31,0		 GN 2/1 mm.685x550x310h	3.570,00
	S7/FUG6LE	1.200x700x850h	 23,1  5,48		 400V3N~ 50/60Hz GN 2/1 mm.685x550x310h	3.756,00





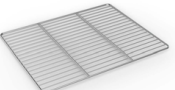













Accessori in dotazione nr.1 griglia interna forno - Accessories included nr.1 internal grid for oven - Zubehöre inbegriffen nr.1 Rost für Ofen - Accessoires inclus nr.1 grille pour four - Accesorios incluidos nr.1 parilla para horno

**ACCESSORI - ACCESSORIES - ZUBEHÖRE - ACCESSOIRES - ACCESORIOS**

	21/GX2/1	530x650	Griglia cromata interna forno - Chrome plated grid for oven - Verchromte Rost für Ofen - Grille chromée pour four - Parilla cromada para horno	75,00
---	----------	---------	--	-------

**CUCINE GAS SEMI-PROFESSIONALI**

 SEMI-PROFESSIONAL GAS RANGES - SEMI-PROFESSIONELLE GASHERDE -  
 CUISINIÈRES GAZ SEMI-PROFESSIONNELLES - COCINAS GAS SEMI  
 PROFESIONALES

	<b>Model</b>	 (A x B x C) mm	<b>kW</b>	<b>Burners</b>	<b>Oven</b>	<b>€</b>
<b>GRIGLIA IN GHISA - CAST IRON GRID - GUSSEISENGITTER - GRILLE EN FONTE - PARILLA EN HIERRO FUNDIDO</b>						
	<b>S7/KUG4BA</b>	800x700x850h	15,4			1.995,00
	<b>S7/KUG6BA</b>	1.200x700x850h	23,1			2.625,00
	<b>S7/KUG4LO</b>	800x700x850h	23,3		 GN 2/1 mm.685x550x310h	2.947,00
	<b>S7/KUG4LE</b>	800x700x850h	15,4 5,48		 400V3N~ 50/60Hz GN 2/1 mm.685x550x310h	3.132,00
	<b>S7/KUG6LN</b>	1.200x700x850h	31,0		 GN 2/1 mm.685x550x310h	3.807,00
	<b>S7/KUG6LE</b>	1.200x700x850h	23,1 5,48		 400V3N~ 50/60Hz GN 2/1 mm.685x550x310h	3.993,00
Accessori in dotazione nr.1 griglia interna forno - Accessories included nr.1 internal grid for oven - Zubehöre inbegriffen nr.1 Rost für Ofen - Accessoires inclus nr.1 grille pour four - Accesorios incluidos nr.1 parilla para horno						

**ACCESSORI - ACCESSORIES - ZUBEHÖRE - ACCESSOIRES - ACCESORIOS**

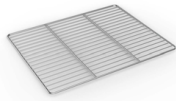
	<b>21/GX2/1</b>	530x650	Griglia cromata interna forno - Chrome plated grid for oven - Verchromte Rost für Ofen - Grille chromée pour four - Parilla cromada para horno	75,00
---	-----------------	---------	--	-------



# FRIGGITRICI PER PASTICCERIA *PASTRY FRYERS*



### FRIGGITRICI PER PASTICCERIA

PASTRY FRYERS - FRITEUSES POUR PÂTISSERIE - FREIDORAS PARA PASTELERÍA

FRIGGITRICI PER PASTICCERIA

	Model	 (A x B x C) mm	Capacity lt	Dim. Tank	Dim. Basket	Power kW	€
<i>FRIGGITRICI ELETTRICHE DA BANCO CON RESISTENZE INTERNE ELECTRIC COUNTER TOP FRYERS WITH INSIDE ELEMENTS</i>							
	<b>FPI070E21</b>	700x650x290h	21	640x380	605x329x70h	 6,0/9,0  380/415V 50/60 Hz	<b>3.037,00</b>
	<b>FPI105E32</b>	1050x650x290h	32	985x380	955x329x70h	 12,0/18,0  380/415V 50/60 Hz	<b>4.466,00</b>
<i>FRIGGITRICI ELETTRICHE DA BANCO CON RESISTENZE ESTERNE ELECTRIC COUNTER TOP FRYERS WITH OUTSIDE ELEMENTS</i>							
	<b>FPE035E05</b>	350x650x290h	5	290x380	255x330x70h	 4,5  380/415V 50/60 Hz	<b>2.594,00</b>
	<b>FPE070E10</b>	700x650x290h	10	640x380	605x330x70h	 9,0  380/415V 50/60 Hz	<b>3.281,00</b>
	<b>FPE105E15</b>	1050x650x290h	15	990x380	955x330x70h	 13,5  380/415V 50/60 Hz	<b>4.777,00</b>
<i>FRIGGITRICI A GAS DA BANCO CON BRUCIATORE INTERNO GAS COUNTER TOP FRYER WITH BURNER INSIDE OF THE TANK</i>							
	<b>FPI070G21</b>	700x650x290h	21	610x343	575x302x70h	 18,0	<b>3.823,00</b>

**FRIGGITRICI PER  
PASTICCERIA**  
*PASTRY FRYERS*

PRICE LIST 2025

**FRIGGITRICI PER PASTICCERIA**  
PASTRY FRYERS - FRITEUSES POUR PÂTISSERIE - FREIDORAS PARA PASTELERÍA

**FRIGGITRICI PER PASTICCERIA**





# PRIME 700

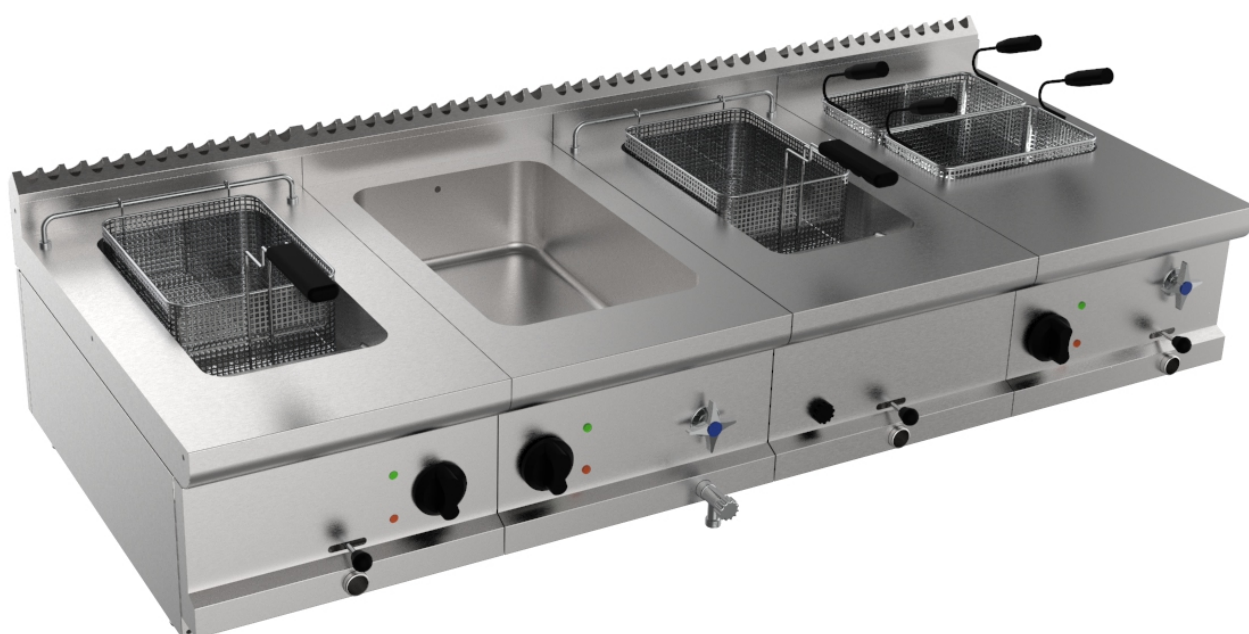





# PRIME 700

## CUCINE GAS





GAS RANGES - GASHERDE - CUISINIÈRES GAZ - COCINAS GAS

PRIME700

	Model	 (A x B x C) mm	kW	Burners	Oven	€
	P7/CUPG2BB.2M	350x700x305h	🔥 9,0	4,5		1.338,00
	P7/KUPG2BB.2M	400x700x305h	🔥 9,0	4,5		1.373,00
	P7/CUPG2BB.1M1G	350x700x305h	🔥 12,0	4,5		1.352,00
	P7/KUPG2BB.1M1G	400x700x305h	🔥 12,0	7,5		1.387,00
	P7/CUPG4BB.4M	700x700x305h	🔥 18,0	4,5 4,5		2.071,00
	P7/KUPG4BB.4M	800x700x305h	🔥 18,0	4,5 4,5		2.139,00
	P7/CUPG4BB.2M2G	700x700x305h	🔥 24,0	4,5 4,5		2.099,00
	P7/KUPG4BB.2M2G	800x700x305h	🔥 24,0	7,5 7,5		2.169,00
	P7/CUPG6BB.6M	1.050x700x305h	🔥 27,0	4,5 4,5 4,5		2.860,00
	P7/KUPG6BB.6M	1.200x700x305h	🔥 27,0	4,5 4,5 4,5		2.914,00
	P7/CUPG6BB.3M3G	1.050x700x305h	🔥 36,0	4,5 4,5 4,5		2.903,00
	P7/KUPG6BB.3M3G	1.200x700x305h	🔥 36,0	7,5 7,5 7,5		2.957,00

## CUCINE ELETTRICHE









ELECTRIC RANGES- ELEKTROHERDE - CUISINIÈRES ÉLECTRIQUES - COCINAS ELÉCTRICAS

	Model	 (A x B x C) mm	kW	Burners	Oven	€
	P7/CUET2BB	400x700x305h	⚡ 5,2 400V3N~ 50/60Hz	2,6 2,6 Ø mm.220		1.194,00
	P7/CUET4BB	800x700x305h	⚡ 10,4 400V3N~ 50/60Hz	2,6 2,6 2,6 2,6 Ø mm.220		1.706,00
	P7/CUET6BB	1.200x700x305h	⚡ 15,6 400V3N~ 50/60Hz	2,6 2,6 2,6 2,6 2,6 2,6 Ø mm.220		2.235,00

# PRIME 700

## FRIGGITRICI A GAS

GAS FRYERS - GAS FRITTEUSEN - FRITEUSES GAZ - FREIDORAS A GAS

	Model	 (A x B x C) mm	kW	Baskets included	Lt.	€
Scambiatori di calore ESTERNI, vasca pulita - EXTERNAL heat exchangers, clean tank - Brenner an der AUßENSEITE des Beckens - Échangeurs de chaleur EXTÉRIEUR à la cuve - Intercambiadores de calor EXTERNOS a la cuba						
 	P7/FRG1V8	400x700x305h	6,6		7	2.528,00
 	P7/FRG2V8	800x700x305h	13,2		7+7	4.304,00
Cestelli e coperchio in dotazione - Equipped with baskets and lid - Inkl. Körbe und Deckel - Paniers et couvercle inclus - Cestas y tapa en dotación						









PRIME700

### ACCESSORI- ACCESSORIES- ZUBEHÖRE- ACCESSOIRES- ACCESORIOS



	21/99600148	228x278x105h	cestello 1/1 per vasca cap.Lt 7 Mod. FRG - basket 1/1 for tank cap. 7 lt. Mod. FRG	116,00
---	-------------	--------------	--	--------

### FRIGGITRICI ELETTRICHE

ELECTRIC FRYERS - ELEKTRO FRITTEUSEN - FRITEUSES ÉLECTRIQUE - FREIDORAS ELÉCTRICAS

	Model	 (A x B x C) mm	kW	Baskets included	Lt.	€
Resistenze rotanti in vasca - Rotating resistors in the tank - Heizkörper mit Dreh-System in Öl getaucht - Résistances immergées rotatives aux bacs - Resistencias rodantes en el tanque						
 	P7/FRE1V8	400x700x305h	6,5 400V3N~ 50/60Hz		7	2.451,00
 	P7/FRE2V8	800x700x305h	13,0 400V3N~ 50/60Hz		7+7	3.960,00
Cestelli e coperchio in dotazione - Equipped with baskets and lid - Inkl. Körbe und Deckel - Paniers et couvercle inclus - Cestas y tapa en dotación						



### ACCESSORI- ACCESSORIES- ZUBEHÖRE- ACCESSOIRES- ACCESORIOS

	21/99600132	109x300x120h	cestello 1/2 per vasca cap.Lt 7 Mod. FRE - basket 1/2 for tank cap. lt.7 Mod. FRE	107,00
	21/99600131	220x300x120h	cestello 1/1 per vasca cap.Lt 7 Mod. FRE - basket 1/1 for tank cap. lt.7 Mod. FRE	118,00





# PRIME 700

## SCALDAPATATE

CHIP SCUTTLE - KARTOFFELWÄRMER - CHAUFFE FRITES - CALIENTA PATATAS

	Model	 (A x B x C) mm	kW	Cap.		€
	P7/SPE40BB	400x700x305h	1,0 230V~ 50/60Hz	GN 1/1	1/1	1.722,00

## CUOCIPASTA PASTA COOKERS - NUDELKOCHER - CUISEUR À PÂTES - CUECE-PASTAS





	Model	 (A x B x C) mm	kW	Lt.	Cap.	€
	P7/KPE1V40BB	400x700x305h	5,52 400V3N~ 50/60Hz	12		2.593,00
	P7/KPE2V80BB	800x700x305h	11,04 400V3N~ 50/60Hz	12+12		4.339,00

Cestelli e coperchi non in dotazione - Baskets and lids are not included - Körbe und Deckeln im Preis nicht imbegriffen - Paniers et couvercles pas compris dans le prix - Cestas y la tapas no incluidas en el precio

## ACCESSORI- ACCESSORIES- ZUBEHÖRE- ACCESSOIRES- ACCESORIOS

	21/99900189	288x140x125h	cestello inox 1/3 con due manici s/s basket 1/3 with two handles		160,00
---	-------------	--------------	---	--	--------

## BAGNOMARIA ELETTRICI ELECTRIC BAINS-MARIE- ELEKTRO WASSERBÄDER- BAINS-MARIE ÉLECTRIQUE - BAÑOS MARÍA ELÉCTRICO







	Model	 (A x B x C) mm	kW	Cap.		€
	P7/KME1BB	400x700x305h	1,5 230V~ 50/60Hz	GN 1/1	1/1	1.599,00
	P7/KME2BB	800x700x305h	3,0 230V~ 50/60Hz	GN 2/1	2/1	2.105,00

GN e coperchi non in dotazione - GN and lids are not included - GN und Deckeln im Preis nicht imbegriffen - Bacs GN et couvercles pas compris dans le prix - Cubetas GN y la tapas no incluidas en el precio

# PRIME 700

## FRY-TOP GAS

GAS GRIDDLE PLATES - GAS GRILLPLATTEN - FRY-TOP GAZ - FRY-TOP A GAS

	Model	F K	 (A x B x C) mm	Kw	UE	Extra UE	Dim.cooking plate mm.	€
	P7/KTG1BBL	F	400x700x305h	6,0		•	400x530	1.926,00
	P7/KTG1BBLK	K						•
	P7/KTG1BBR	F	400x700x305h	6,0		•	400x530	1.960,00
	P7/KTG1BBRK	K						•
	P7/FTG2BBL	F	700x700x305h	12,0		•	700x530	2.509,00
	P7/FTG2BBLK	K						•
	P7/KTG2BBL	F	800x700x305h	12,0		•	800x530	2.559,00
	P7/KTG2BBLK	K						•
	P7/FTG2BBR	F	700x700x305h	12,0		•	700x530	2.715,00
	P7/FTG2BBRK	K						•
	P7/KTG2BBR	F	800x700x305h	12,0		•	800x530	2.773,00
	P7/KTG2BBRK	K						•
	P7/FTG2BBM	F	700x700x305h	12,0		•	700x530	2.602,00
	P7/FTG2BBMK	K						•
	P7/KTG2BBM	F	800x700x305h	12,0		•	800x530	2.655,00
	P7/KTG2BBMK	K						•

Placa - Semi-mild steel plate - Halbweiche Stahlplatte - Plaque en acier demi-doux - Plancha de acero semi-

suave







K - Piastra conforme a normativa CE 1935/2004-MOCA - Plate in compliance with EC 1935/2004 Regulation-FCM - LKM-Platte konform mit CE 1935/2004 - Plaque en ligne avec le règlement CE 1935/2004-MCDA - Plancha conforme al reglamento CE 1935/2004-MOCA

# PRIME 700

## FRY-TOP ELETTRICO

ELECTRIC GRIDDLE PLATES - ELEKTRO GRILLPLATTEN - FRY-TOP ÉLECTRIQUE - FRY-TOP ELÉCTRICOS

PRIME700

	Model	F K	 (A x B x C) mm	kW	UE	Extra UE	Dim.cooking plate mm.	€
	P7/KTE1BBL	F	400x700x305h	5,4 400V3N~ 50/60Hz		•	400x530	2.013,00
	P7/KTE1BBLK	K						•
	P7/KTE1BBR	F	400x700x305h	5,4 400V3N~ 50/60Hz		•	400x530	2.046,00
	P7/KTE1BBRK	K						•
	P7/FTE2BBL	F	700x700x305h	10,8 400V3N~ 50/60Hz		•	700x530	2.620,00
	P7/FTE2BBLK	K						•
	P7/KTE2BBL	F	800x700x305h	10,8 400V3N~ 50/60Hz		•	800x530	2.674,00
	P7/KTE2BBLK	K						•
	P7/FTE2BBR	F	700x700x305h	10,8 400V3N~ 50/60Hz		•	700x530	2.836,00
	P7/FTE2BBRK	K						•
	P7/KTE2BBR	F	800x700x305h	10,8 400V3N~ 50/60Hz		•	800x530	2.895,00
	P7/KTE2BBRK	K						•
	P7/FTE2BBM	F	700x700x305h	10,8 400V3N~ 50/60Hz		•	700x530	2.720,00
	P7/FTE2BBMK	K						•
	P7/KTE2BBM	F	800x700x305h	10,8 400V3N~ 50/60Hz		•	800x530	2.775,00
	P7/KTE2BBMK	K						•







**F** - Piastra in acciaio semi-dolce - Semi-mild steel plate - Halbweiche Stahlplatte - Plaque en acier demi-doux - Plancha de acero semi-suave

**K** - Piastra conforme a normativa CE 1935/2004-MOCA - Plate in compliance with EC 1935/2004 Regulation-FCM - LKM-Platte konform mit CE 1935/2004 - Plaque en ligne avec le règlement CE 1935/2004-MCDA - Plancha conforme al reglamento CE 1935/2004-MOCA

# PRIME 700

## GRIGLIE A PIETRA LAVICA



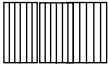

LAVASTONE GRILL - LAVASTEIN-GRILL - GRILLES PIERRE VOLCANIQUE -  
PARRILLAS DE PIEDRA VOLCÁNICA

	Model	 (A x B x C) mm	kW	Grid	Kg. Lava rock	€
	P7/BS1BB	400x700x305h	8,0		5	2.274,00
	P7/BS2BB	800x700x305h	16,0		10	3.386,00
	P7/BS3BB	1200x700x305h	24,0		18	5.121,00

PRIME700

### ELEMENTI NEUTRI

NEUTRAL UNITS- ARBEITSELEMENTE - ELEMENTS NEUTRES - MUEBLES NEUTROS







	Model	 (A x B x C) mm		€
	P7/ENN1BB	350x700x305h		645,00
	P7/ENN1CB	350x700x305h	con 1 cassetto - with 1 drawer - mit 1 Schublade - avec 1 tiroir - con 1 cajón	1.112,00
	P7/KNN1BB	400x700x305h		681,00
	P7/KNN1CB	400x700x305h	con 1 cassetto GN 1/1 - with 1 drawer GN 1/1- mit 1 Schublade GN 1/1 - avec 1 tiroir GN 1/1 - con 1 cajón GN 1/1	1.150,00
	P7/ENN2BB	700x700x305h		811,00
	P7/ENN2CB	700x700x305h	con 1 cassetto - with 1 drawer - mit 1 Schublade - avec 1 tiroir - con 1 cajón	1.317,00
	P7/KNN2BB	800x700x305h		857,00
	P7/KNN2CB	800x700x305h	con 1 cassetto GN 2/1 - with 1 drawer GN 2/1- mit 1 Schublade GN 2/1 - avec 1 tiroir GN 2/1 - con 1 cajón GN 2/1	1.364,00

# PRIME 700

## ACCESSORI

ACCESSORIES- ZUBEHÖRE- ACCESSOIRES- ACCESORIOS

PRIME700

	Model	 (A x B x C) mm	Description	€
<b>ACCESSORI- ACCESSORIES- ZUBEHÖRE- ACCESSOIRES- ACCESORIOS</b>				
	<b>P7/EX035</b>	350x50x100h	Prolunga camino - Flue extentions	<b>149,00</b>
	<b>P7/EX040</b>	400x50x100h	Prolunga camino - Flue extentions	<b>158,00</b>
	<b>P7/EX070</b>	700x50x100h	Prolunga camino - Flue extentions	<b>215,00</b>
	<b>P7/EX080</b>	800x50x100h	Prolunga camino - Flue extentions	<b>234,00</b>
	<b>P7/EX105</b>	1.050x50x100h	Prolunga camino - Flue extentions	<b>284,00</b>
	<b>P7/EX120</b>	1.200x50x100h	Prolunga camino - Flue extentions	<b>309,00</b>
	<b>15/99901029</b>		Riduzione per griglia - Reduction grid for grid - Reduzierrost für Rost - Grille de reduction pour support poele -Rejilla reductore para parrilla	<b>50,00</b>
<b>ACCESSORI- ACCESSORIES- ZUBEHÖRE- ACCESSOIRES- ACCESORIOS</b>				
	<b>56/89900004</b>	530x325x100h	Vaschetta inox - S/s GN 1/1 cap. lt 21,3	<b>61,00</b>
	<b>56/89900064</b>	354x325x100h	Vaschetta inox - S/s GN 2/3 cap. lt 13,2	<b>49,00</b>
	<b>56/89900031</b>	265x325x100h	Vaschetta inox - S/s GN 1/2 cap. lt 9,7	<b>41,00</b>
	<b>56/89900011</b>	176x325x100h	Vaschetta inox - S/s GN 1/3 cap. lt 5,8	<b>29,00</b>
	<b>56/89900041</b>	162x265x100h	Vaschetta inox - S/s GN 1/4 cap. lt 4,1	<b>25,00</b>
	<b>56/89900021</b>	162x176x100h	Vaschetta inox - S/s GN 1/6 cap. lt 2,4	<b>20,00</b>
	<b>56/89901002</b>	530x325	Coperchio inox - S/s lid GN 1/1	<b>28,00</b>
	<b>56/89901006</b>	354x325	Coperchio inox - S/s lid GN 2/3	<b>26,00</b>
	<b>56/89901001</b>	265x325	Coperchio inox - S/s lid GN 1/2	<b>21,00</b>
	<b>56/89901007</b>	176x325	Coperchio inox - S/s lid GN 1/3	<b>17,00</b>
	<b>56/89901003</b>	162x265	Coperchio inox - S/s lid GN 1/4	<b>14,00</b>
	<b>56/89901000</b>	162x176	Coperchio inox - S/s lid GN 1/6	<b>15,00</b>
	<b>23/99600003</b>		Divisorio bacinelle - Dividing element for GN	<b>30,00</b>



# Easy700



# Easy700

## CUCINE GAS

GAS RANGES - GASHERDE - CUISINIÈRES GAZ - COCINAS GAS

	Model	 (A x B x C) mm	kW	Burners	Oven	€
	Versione da banco - Bench model - Auf Tischmodell - Modèle à poser - Modelo de sobremesa					
	E7/CUPG2BB.2M	350x700x275h	9,0	4,5		1.318,00
	E7/KUPG2BB.2M	400x700x275h	9,0	4,5		1.352,00
	E7/CUPG2BB.1M1G	350x700x275h	12,0	4,5		1.333,00
	E7/KUPG2BB.1M1G	400x700x275h	12,0	7,5		1.367,00
	E7/CUPG4BB.4M	700x700x275h	18,0	4,5 4,5		2.040,00
	E7/KUPG4BB.4M	800x700x275h	18,0	4,5 4,5		2.107,00
	E7/CUPG4BB.2M2G	700x700x275h	24,0	4,5 4,5		2.067,00
	E7/KUPG4BB.2M2G	800x700x275h	24,0	7,5 7,5		2.136,00
	E7/CUPG6BB.6M	1.050x700x275h	27,0	4,5 4,5 4,5		2.817,00
	E7/KUPG6BB.6M	1.200x700x275h	27,0	4,5 4,5 4,5		2.870,00
	E7/CUPG6BB.3M3G	1.050x700x275h	36,0	4,5 4,5 4,5		2.859,00
	E7/KUPG6BB.3M3G	1.200x700x275h	36,0	7,5 7,5 7,5		2.913,00
	Modello su vano a giorno - Model on open cabinet - Modell mit offenem Unterbau - Modèle sur meuble ouvert - Modelo abierto					
	E7/CUPG2BA.2M	350x700x850h	9,0	4,5		1.533,00
	E7/KUPG2BA.2M	400x700x850h	9,0	4,5		1.566,00
	E7/CUPG2BA.1M1G	350x700x850h	12,0	4,5		1.546,00
	E7/KUPG2BA.1M1G	400x700x850h	12,0	7,5		1.581,00
	E7/CUPG4BA.4M	700x700x850h	18,0	4,5 4,5		2.296,00
	E7/KUPG4BA.4M	800x700x850h	18,0	4,5 4,5		2.362,00
	E7/CUPG4BA.2M2G	700x700x850h	24,0	4,5 4,5		2.323,00
	E7/KUPG4BA.2M2G	800x700x850h	24,0	7,5 7,5		2.391,00
	E7/CUPG6BA.6M	1.050x700x850h	27,0	4,5 4,5 4,5		3.056,00
	E7/KUPG6BA.6M	1.200x700x850h	27,0	4,5 4,5 4,5		3.136,00
	E7/CUPG6BA.3M3G	1.050x700x850h	36,0	4,5 4,5 4,5		3.098,00
	E7/KUPG6BA.3M3G	1.200x700x850h	36,0	7,5 7,5 7,5		3.178,00

EASY700

# Easy700

## CUCINE GAS

GAS RANGES - GASHERDE - CUISINIÈRES GAZ - COCINAS GAS

	Model		kW	Burners	Oven	€
Modello con forno - Model with oven - Modell mit Backofen - Modèle avec four - Modelo con horno						
	E7/CUPG4FO.4M	700x700x850h	25,9		 mm.585x550x310h	3.519,00
	E7/CUPG4FO.2M2G	700x700x850h	31,9		 mm.585x550x310h	3.548,00
	E7/KUPG4LO.4M	800x700x850h	25,9		 GN 2/1 mm.685x550x310h	3.589,00
	E7/KUPG4LO.2M2G	800x700x850h	31,9		 GN 2/1 mm.685x550x310h	3.618,00
	E7/CUPG4FE.4M	700x700x850h	18,0 5,48		 400V3N~ 50/60Hz mm.585x550x310h	3.711,00
	E7/CUPG4FE.2M2G	700x700x850h	24,0 5,48		 400V3N~ 50/60Hz mm.585x550x310h	3.738,00
	E7/KUPG4LE.4M	800x700x850h	18,0 5,48		 400V3N~ 50/60Hz GN 2/1 mm.685x550x310h	3.778,00
	E7/KUPG4LE.2M2G	800x700x850h	24,0 5,48		 400V3N~ 50/60Hz GN 2/1 mm.685x550x310h	3.806,00
	E7/CUPG6FN.6M	1.050x700x850h	34,9		 mm.585x550x310h	4.570,00
	E7/CUPG6FN.3M3G	1.050x700x850h	43,9		 mm.585x550x310h	4.612,00
	E7/KUPG6LN.6M	1.200x700x850h	34,9		 GN 2/1 mm.685x550x310h	4.652,00
	E7/KUPG6LN.3M3G	1.200x700x850h	43,9		 GN 2/1 mm.685x550x310h	4.693,00
	E7/CUPG6FE.6M	1.050x700x850h	27,0 5,48		 400V3N~ 50/60Hz mm.585x550x310h	4.845,00
	E7/CUPG6FE.3M3G	1.050x700x850h	36,0 5,48		 400V3N~ 50/60Hz mm.585x550x310h	4.888,00
	E7/KUPG6LE.6M	1.200x700x850h	27,0 5,48		 400V3N~ 50/60Hz GN 2/1 mm.685x550x310h	4.845,00
	E7/KUPG6LE.3M3G	1.200x700x850h	36,0 5,48		 400V3N~ 50/60Hz GN 2/1 mm.685x550x310h	4.888,00

EASY700

## CUCINE GAS

GAS RANGES - GASHERDE - CUISINIÈRES GAZ - COCINAS GAS

	Model	 A B C (A x B x C) mm	kW	Burners	Oven	€
	E7/CUPG6FM.6M	1.050x700x850h	39,0		 MAXI mm.935x550x310h	4.954,00
	E7/CUPG6FM.3M3G	1.050x700x850h	48,0		 MAXI mm.935x550x310h	4.997,00
	E7/KUPG6FM.6M	1.200x700x850h	39,0		 MAXI mm.935x550x310h	5.039,00
	E7/KUPG6FM.3M3G	1.200x700x850h	48,0		 MAXI mm.935x550x310h	5.080,00

Accessori in dotazione nr.1 griglia interna forno e nr. 1 riduzione fuoco - Accessories included nr.1 internal grid for oven and nr.1 reduction for burner - Zubehöre  
inbegriffen nr.1 Rost für Ofen und nr.1 Reduzierrost für Brenner - Accessoires inclus nr.1 grille pour four et nr.1 grille de réduction pour brûleur - Accesorios incluidos  
nr.1 parilla para horno y nr.1 rejilla reductora para quemador

### CUCINE ELETTRICHE









#### ELECTRIC RANGES- ELEKTROHERDE - CUISINIÈRES ÉLECTRIQUES - COCINAS ELÉCTRICAS

	Model	 A B C (A x B x C) mm	kW	Burners	Oven	€
Versione da banco - Bench model - Aufschischmodell - Modèle à poser - Modelo de sobremesa						
	E7/CUET2BB	400x700x275h	5,2 400V3N~ 50/60Hz	 Ø mm.220		1.174,00
	E7/CUET4BB	800x700x275h	10,4 400V3N~ 50/60Hz	 Ø mm.220		1.679,00
	E7/CUET6BB	1.200x700x275h	15,6 400V3N~ 50/60Hz	 Ø mm.220		2.202,00
Modello su vano a giorno - Model on open cabinet - Modell mit offenem Unterbau - Modèle sur meuble ouvert - Modelo abierto						
	E7/CUET2BA	400x700x850h	5,2 400V3N~ 50/60Hz	 Ø mm.220		1.448,00
	E7/CUET4BA	800x700x850h	10,4 400V3N~ 50/60Hz	 Ø mm.220		2.054,00
	E7/CUET6BA	1.200x700x850h	15,6 400V3N~ 50/60Hz	 Ø mm.220		2.743,00

# Easy700

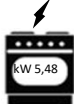
## CUCINE ELETTRICHE

ELECTRIC RANGES- ELEKTROHERDE - CUISINIÈRES ÉLECTRIQUES - COCINAS ELÉCTRICAS

	Model	 (A x B x C) mm	kW	Burners	Oven	€
Modello con forno elettrico - Model with electric oven - Modell mit Elektro-Backofen - Modèle avec four électrique - Modelo con horno eléctrico						
	E7/CUET4LE	800x700x850h	⚡ 15,88 400V3N~ 50/60Hz	 Ø mm.220	 kW 5,48 400V3N~ 50/60Hz GN 2/1 mm.685x550x310h	3.775,00
	E7/CUET6LE	1.200x700x850h	⚡ 21,08 400V3N~ 50/60Hz	 Ø mm.220	 kW 5,48 400V3N~ 50/60Hz GN 2/1 mm.685x550x310h	4.715,00

Accessori in dotazione nr.1 griglia interna forno - Accessories included nr.1 internal grid for oven - Zubehörte inbegriffen nr.1 Rost für Ofen - Accessoires inclus nr.1 grille pour four - Accesorios incluidos nr.1 parilla para horno

## SCALDAPATATE CHIP SCUTTLE - KARTOFFELWÄRMER - CHAUFFE FRITES - CALIENTA PATATAS

	Model	 (A x B x C) mm	kW	Cap.	€
	E7/SPE40BB	400x700x275h	⚡ 1,0 230V~ 50/60Hz	GN 1/1 	1.697,00
	E7/SPE40BA	400x700x850h	⚡ 1,0 230V~ 50/60Hz	GN 1/1 	1.908,00
	E7/SPE40BC	400x700x850h	⚡ 1,0 230V~ 50/60Hz	GN 1/1 	2.087,00

		Model	 A B C (A x B x C) mm	kW	Baskets included	Lt.	€
Scambiatori di calore INTERNI - INTERNAL heat exchangers - Wärmetauschbrenner INNERHALB des Beckens - Échangeurs de chaleur INTERNES à la cuve - Intercambiadores de calor EN el tanque							
		E7/FLG1V13	400x700x850h	11,2		13	3.215,00
		E7/FLG1V17	400x700x850h	16,5		17	3.614,00
		E7/FLG2V8	400x700x850h	11,6		8+8	4.868,00
		E7/FLG2V13	800x700x850h	22,4		13+13	5.563,00
		E7/FLG2V17	800x700x850h	33,0		17+17	6.304,00

Cestelli, coperchio e n.1 vasca raccogli olio in dotazione - Equipped with baskets, lid and n.1 s/s oil draining tank - Inkl. Körbe, Deckel und n.1 Ölauffangbecken aus Edelstahl - Paniers, couvercle et n.1 bac de récupération huile en acier inoxydable inclus - Cestas, la tapa y n.1 barreño recoge aceite en acero inoxidable en dotación

## ACCESSORI- ACCESSORIES- ZUBEHÖRE- ACCESSOIRES- ACCESORIOS

	21/99600132	109x300x120h	cestello 1/2 per vasca cap.Lt 13 Mod. FLG/FRE - basket 1/2 for tank cap. lt.13 Mod. FLG/FRE	107,00
	21/99600133	140x300x120h	cestello 1/2 per vasca cap.Lt 17 Mod. FLG/FRE - basket 1/2 for tank cap. lt.17 Mod. FLG/FRE	110,00
	21/99600131	220x300x120h	cestello 1/1 per vasca cap.Lt 13 Mod. FLG/FRE - basket 1/1 for tank cap. lt.13 Mod. FLG/FRE	118,00
	21/99600134	290x300x120h	cestello 1/1 per vasca cap.Lt 17 Mod. FLG/FRE - basket 1/1 for tank cap. lt.17 Mod. FLG/FRE	121,00
	21/99600130	120x300x120h	cestello per vasca cap.Lt 8 Mod. FLG/FRE - basket for tank cap. lt.8 Mod. FLG/FRE	110,00
	WD/99600001		vasca raccogli olio supplementare - additional oil draining tank	246,00

## FRIGGITRICI ELETTRICHE

ELECTRIC FRYERS - ELEKTRO FRITTEUSEN - FRITEUSES ÉLECTRIQUE - FREIDORAS ELÉCTRICAS

	Model	 (A x B x C) mm	kW	Baskets included	Lt.	€
	Resistenze rotanti in vasca - Rotating resistors in the tank - Heizkörper mit Dreh-System in Öl getaucht - Résistances immergées rotatives aux bacs - Resistencias rodantes en el tanque					
	<b>E7/FRE1V13</b>	400x700x850h	⚡ 12,0 400V3N~ 50/60Hz		13	<b>2.862,00</b>
	<b>E7/FRE1V17</b>	400x700x850h	⚡ 16,5 400V3N~ 50/60Hz		17	<b>3.047,00</b>
	<b>E7/FRE2V8</b>	400x700x850h	⚡ 14,0 400V3N~ 50/60Hz		8+8	<b>3.815,00</b>
	<b>E7/FRE2V13</b>	800x700x850h	⚡ 24,0 400V3N~ 50/60Hz		13+13	<b>4.581,00</b>
	<b>E7/FRE2V17</b>	800x700x850h	⚡ 33,0 400V3N~ 50/60Hz		17+17	<b>4.668,00</b>

EASY700

Cestelli, coperchio e n.1 vasca raccogli olio in dotazione - Equipped with baskets, lid and n.1 s/s oil draining tank - Inkl. Körbe, Deckel und n.1 Ölauffangbecken aus Edelstahl - Paniers, couvercle et n.1 bac de récupération huile en acier inoxydable inclus - Cestas, la tapa y n.1 barreño recoge aceite en acero inoxidable en dotación









## ACCESSORI- ACCESSORIES- ZUBEHÖRE- ACCESSOIRES- ACCESORIOS

	<b>21/99600132</b>	109x300x120h	cestello 1/2 per vasca cap.Lt 13 Mod. FLG/FRE - basket 1/2 for tank cap. lt.13 Mod. FLG/FRE	<b>107,00</b>
	<b>21/99600133</b>	140x300x120h	cestello 1/2 per vasca cap.Lt 17 Mod. FLG/FRE - basket 1/2 for tank cap. lt.17 Mod. FLG/FRE	<b>110,00</b>
	<b>21/99600131</b>	220x300x120h	cestello 1/1 per vasca cap.Lt 13 Mod. FLG/FRE - basket 1/1 for tank cap. lt.13 Mod. FLG/FRE	<b>118,00</b>
	<b>21/99600134</b>	290x300x120h	cestello 1/1 per vasca cap.Lt 17 Mod. FLG/FRE - basket 1/1 for tank cap. lt.17 Mod. FLG/FRE	<b>121,00</b>
	<b>21/99600130</b>	120x300x120h	cestello per vasca cap.Lt 8 Mod. FLG/FRE - basket for tank cap. lt.8 Mod. FLG/FRE	<b>110,00</b>
	<b>WD/99600001</b>		vasca raccogli olio supplementare - additional oil draining tank	<b>246,00</b>







# Easy700

## CUOCIPASTA

PASTA COOKERS - NUDELKOCHER - CUISEUR À PÂTES - CUECE-PASTAS

	Model	 (A x B x C) mm	kW	Lt.	Cap.	€
Versione gas - Gas model - Gasmodell - Modèle à gaz - Modelo gas						
	<b>E7/KPG1V40</b>	400x700x850h	 11,0	28		<b>3.061,00</b>
	<b>E7/KPG2V80</b>	800x700x850h	 22,0	28+28	 	<b>5.133,00</b>

Cestelli e coperchi non in dotazione - Baskets and lids are not included - Körbe und Deckeln im Preis nicht imbegriffen - Paniers et couvercles pas compris dans le prix - Cestas y la tapas no incluidas en el precio















Versione elettrica - Electric model - Elektromodell - Modèle électrique - Modelo eléctricos						
	<b>E7/KPE1V40</b>	400x700x850h	 7,0  400V3N~ 50/60Hz	28		<b>3.344,00</b>
	<b>E7/KPE2V80</b>	800x700x850h	 14,0  400V3N~ 50/60Hz	28+28	 	<b>5.598,00</b>

Cestelli e coperchi non in dotazione - Baskets and lids are not included - Körbe und Deckeln im Preis nicht imbegriffen - Paniers et couvercles pas compris dans le prix - Cestas y la tapas no incluidas en el precio

# Easy700

## ACCESSORI PER CUOCIPASTA

ACCESSORIES FOR PASTA COOKERS - ZUBEHÖRE FÜR NUDELKOCHER - ACCESSOIRES  
POUR CUISEUR À PÂTES - ACCESORIOS PARA CUECE-PASTAS







	Model		kW	Lt.	Cap.	€
<b>ACCESSORI- ACCESSORIES- ZUBEHÖRE- ACCESSOIRES- ACCESORIOS</b>						
	<b>SET 700CESA</b> 2 X 21/99900147 2 X 21/99900148	nr.4 x 143x163x215h			nr.4 cestelli inox 1/6 nr.4 s/s baskets 1/6	<b>527,00</b>
	<b>SET 700CESB</b> 2 X 21/99900148 1 X 21/99900000	nr.2 x 143x163x215h + nr.1 x 290x143x215h			nr.2 cestelli inox 1/6 + nr.1 cestello inox 1/3 con un manico nr.2 s/s baskets 1/6 + nr.1 s/s basket 1/3 with one handle	<b>420,00</b>
	<b>SET 700CESC</b> 2 X 21/99900000	nr.2 x 290x143x215h			nr.2 cestelli inox 1/3 con un manico nr.2 s/s baskets 1/3 with one handle	<b>313,00</b>
	<b>SET 700CESD</b> 1 X 21/99900159	nr.1 x 325x290x215h			nr.1 cestello inox 2/3 con due manici nr.1 s/s basket 2/3 with two handles	<b>219,00</b>
	<b>SET 700CESE</b> 2 X 21/99900081	nr.2 x 288x163x215h			nr.2 cestelli inox 1/3 con due manici nr.2 s/s baskets 1/3 with two handles	<b>336,00</b>
	<b>SET 700CESF</b> 1 X 21/99900147 1 X 21/99900148 1 X 21/99900081	nr.2 x 143x163x215h + nr.1 x 288x163x215h			nr.2 cestelli inox 1/6 + nr.1 cestello inox 1/3 con due manici nr.2 s/s baskets 1/6 + nr.1 s/s basket 1/3 with two handles	<b>431,00</b>
	21/99900147	143x163x215h			cestello 1/6 con manico a destra s/s basket 1/6 with right-hand side handle	<b>132,00</b>
	21/99900148	143x163x215h			cestello inox 1/6 con manico a sinistra s/s basket 1/6 with left-hand side handle	<b>132,00</b>
	21/99900000	290x143x215h			cestello inox 1/3 con un manico s/s basket 1/3 with one handle	<b>157,00</b>
	21/99900081	288x163x215h			cestello inox 1/3 con due manici s/s basket 1/3 with two handles	<b>168,00</b>
	23/99600128	380x270			coperchio inox per vasca lt. 28 s/s 304 lid for tank lt. 28	<b>103,00</b>
	21/99900179	d. 145x200h			cestello tondo d. 145 mm - round s/s basket d. 145 mm	<b>136,00</b>
	<b>SET700CESG</b> 4 X 21/99900179	nr. 4 x d. 145x200h			nr. 4 cestelli tondi d. 145 mm - nr. 4 round s/s baskets d. 145 mm	<b>543,00</b>
	23/99909200				supporto cestelli tondi per vasca GN 1/1 - support for round baskets - tank GN 1/1	<b>112,00</b>

EASY700

# Easy700

## BAGNOMARIA ELETTRICI

ELECTRIC BAINS-MARIE- ELEKTRO WASSERBÄDER- BAINS-MARIE ÉLECTRIQUE - BAÑOS MARÍA ELÉCTRICO

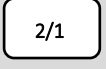
	Model	 (A x B x C) mm	kW	Cap.	€
	E7/KME1BA	400x700x850h	 1,5 230V~ 50/60Hz	GN 1/1 	<b>1.830,00</b>
	E7/KME2BA	800x700x850h	 3,0 230V~ 50/60Hz	GN 2/1 	<b>2.385,00</b>



GN e coperchi non in dotazione - GN and lids are not included - GN und Deckeln im Preis nicht imbegriffen - Bacs GN et couvercles pas compris dans le prix - Cubetas GN y la tapas no incluidas en el precio

EASY700

### ACCESSORI- ACCESSORIES- ZUBEHÖRE- ACCESSOIRES- ACCESORIOS





















	56/89900006	530x325x150h	Vaschetta inox - S/s GN 1/1 cap. lt 21,3	<b>84,00</b>
	56/89900060	354x325x150h	Vaschetta inox - S/s GN 2/3 cap. lt 13,2	<b>60,00</b>
	56/89900030	265x325x150h	Vaschetta inox - S/s GN 1/2 cap. lt 9,7	<b>50,00</b>
	56/89900010	176x325x150h	Vaschetta inox - S/s GN 1/3 cap. lt 5,8	<b>41,00</b>
	56/89900040	162x265x150h	Vaschetta inox - S/s GN 1/4 cap. lt 4,1	<b>32,00</b>
	56/89900020	162x176x150h	Vaschetta inox - S/s GN 1/6 cap. lt 2,4	<b>31,00</b>
	56/89901002	530x325	Coperchio inox - S/s lid GN 1/1	<b>28,00</b>
	56/89901006	354x325	Coperchio inox - S/s lid GN 2/3	<b>26,00</b>
	56/89901001	265x325	Coperchio inox - S/s lid GN 1/2	<b>21,00</b>
	56/89901007	176x325	Coperchio inox - S/s lid GN 1/3	<b>17,00</b>
	56/89901003	162x265	Coperchio inox - S/s lid GN 1/4	<b>14,00</b>
	56/89901000	162x176	Coperchio inox - S/s lid GN 1/6	<b>15,00</b>
	23/99600003		Divisorio bacinelle - Dividing element for GN	<b>30,00</b>

### ACCESSORI- ACCESSORIES- ZUBEHÖRE- ACCESSOIRES- ACCESORIOS

	15/99901889		Pietra lavica - Lava rock - Lavastein - Lave volcanique - Lava Volcànica	<b>12,00 al Kg</b>
	21/99600004	375x461	Griglia inox a canaletto per carne - S/s "V" shape cooking grid for meat	<b>192,00</b>
	21/99600003	775x461	Griglia inox a canaletto per carne - S/s "V" shape cooking grid for meat	<b>310,00</b>
	21/99600002	375x461	Griglia inox in tondino Ø mm.8 per pesce - S/s round cooking grid Ø mm.8 for fish	<b>302,00</b>
	21/99600001	775x461	Griglia inox in tondino Ø mm.8 per pesce - S/s round cooking grid Ø mm.8 for fish	<b>464,00</b>

# Easy700

## GRIGLIE A PIETRA LAVICA LAVASTONE GRILL - LAVASTEIN-GRILL - GRILLES PIERRE VOLCANIQUE - PARRILLAS DE PIEDRA VOLCÁNICA

	Model	 (A x B x C) mm	kW	Grid	Kg. Lava rock	€
	E7/BS1BB	400x700x275h	8,0		5	2.307,00
	E7/BS2BB	800x700x275h	16,0		10	3.435,00
	E7/BS3BB	1200x700x275h	24,0		18	5.197,00
	E7/BS1BA	400x700x850h	8,0		5	2.529,00
	E7/BS2BA	800x700x850h	16,0		10	3.711,00
	E7/BS3BA	1200x700x850h	24,0		18	5.490,00
	E7/BS1BC	400x700x850h	8,0		5	2.705,00
	E7/BS2BC	800x700x850h	16,0		10	4.061,00
	E7/BS3BC2	1200x700x850h	24,0		18	5.982,00

EASY700

# Easy700

## FRY-TOP GAS

GAS GRIDDLE PLATES - GAS GRILLPLATTEN - FRY-TOP GAZ - FRY-TOP A GAS

	Model	F K	 (A x B x C) mm	Kw	UE	Extra UE	Dim.cooking plate mm.	€
	E7/KTG1BBL	F	400x700x275h	6,0		•	396x530	1.896,00
	E7/KTG1BBLK	K						•
	E7/KTG1BBR	F	400x700x275h	6,0		•	396x530	1.930,00
	E7/KTG1BBRK	K						•
	E7/FTG2BBL	F	700x700x275h	12,0		•	696x530	2.470,00
	E7/FTG2BBLK	K						•
	E7/KTG2BBL	F	800x700x275h	12,0		•	796x530	2.521,00
	E7/KTG2BBLK	K						•
	E7/FTG2BBR	F	700x700x275h	12,0		•	696x530	2.676,00
	E7/FTG2BBRK	K						•
	E7/KTG2BBR	F	800x700x275h	12,0		•	796x530	2.731,00
	E7/KTG2BBRK	K						•
	E7/FTG2BBM	F	700x700x275h	12,0		•	696x530	2.562,00
	E7/FTG2BBMK	K						•
	E7/KTG2BBM	F	800x700x275h	12,0		•	796x530	2.616,00
	E7/KTG2BBMK	K						•



**F** - Piastra in acciaio semi-dolce - Semi-mild steel plate - Halbweiche Stahlplatte - Plaque en acier demi-doux - Plancha de acero semi-suave

**K** - Piastra conforme a normativa CE 1935/2004-MOCA - Plate in compliance with EC 1935/2004 Regulation-FCM - LKM-Platte konform mit CE 1935/2004 - Plaque en ligne avec le règlement CE 1935/2004-MCDA - Plancha conforme al reglamento CE 1935/2004-MOCA

# Easy700

## FRY-TOP GAS

GAS GRIDDLE PLATES - GAS GRILLPLATTEN - FRY-TOP GAZ - FRY-TOP A GAS

	Model	F K	 (A x B x C) mm	kW	UE	Extra UE	Dim.cooking plate mm.	€
	E7/KTG1BAL	F	400x700x850h	6,0		•	396x530	2.118,00
	E7/KTG1BALK	K						•
	E7/KTG1BAR	F	400x700x850h	6,0		•	396x530	2.170,00
	E7/KTG1BARK	K						•
	E7/FTG2BAL	F	700x700x850h	12,0		•	696x530	2.757,00
	E7/FTG2BALK	K						•
	E7/KTG2BAL	F	800x700x850h	12,0		•	796x530	2.815,00
	E7/KTG2BALK	K						•
	E7/FTG2BAR	F	700x700x850h	12,0		•	696x530	2.961,00
	E7/FTG2BARK	K						•
	E7/KTG2BAR	F	800x700x850h	12,0		•	796x530	3.024,00
	E7/KTG2BARK	K						•
	E7/FTG2BAM	F	700x700x850h	12,0		•	696x530	2.852,00
	E7/FTG2BAMK	K						•
	E7/KTG2BAM	F	800x700x850h	12,0		•	796x530	2.910,00
	E7/KTG2BAMK	K						•

EASY700

F - Piastra in acciaio semi-dolce - Semi-mild steel plate - Halbweiche Stahlplatte - Plaque en acier demi-doux - Plancha de acero semi-suave

K - Piastra conforme a normativa CE 1935/2004-MOCA - Plate in compliance with EC 1935/2004 Regulation-FCM - LKM-Platte konform mit CE 1935/2004 - Plaque en ligne avec le règlement CE 1935/2004-MCDA - Plancha conforme al reglamento CE 1935/2004-MOCA

### ACCESSORI- ACCESSORIES- ZUBEHÖRE- ACCESSOIRES- ACCESORIOS

	E7/CH035	mm.350	Anta - Door - Tür - Porte - Puerta	172,00
	E7/CH040	mm.400	Anta - Door - Tür - Porte - Puerta	181,00

# Easy700

## FRY-TOP ELETTRICO

ELECTRIC GRIDDLE PLATES - ELEKTRO GRILLPLATTEN - FRY-TOP ÉLECTRIQUE - FRY-TOP ELÉCTRICOS

EASY700

	Model	F K		kW	UE	Extra UE	Dim.cooking plate mm.	€
	E7/KTE1BBL	F	400x700x275h	5,4 400V3N~ 50/60Hz		•	396x530	1.982,00
	E7/KTE1BBLK	K						•
	E7/KTE1BBR	F	400x700x275h	5,4 400V3N~ 50/60Hz		•	396x530	2.015,00
	E7/KTE1BBRK	K						•
	E7/FTE2BBL	F	700x700x275h	10,8 400V3N~ 50/60Hz		•	696x530	2.580,00
	E7/FTE2BBLK	K						•
	E7/KTE2BBL	F	800x700x275h	10,8 400V3N~ 50/60Hz		•	796x530	2.634,00
	E7/KTE2BBLK	K						•
	E7/FTE2BBR	F	700x700x275h	10,8 400V3N~ 50/60Hz		•	696x530	2.794,00
	E7/FTE2BBRK	K						•
	E7/KTE2BBR	F	800x700x275h	10,8 400V3N~ 50/60Hz		•	796x530	2.852,00
	E7/KTE2BBRK	K						•
	E7/FTE2BBM	F	700x700x275h	10,8 400V3N~ 50/60Hz		•	696x530	2.679,00
	E7/FTE2BBMK	K						•
	E7/KTE2BBM	F	800x700x275h	10,8 400V3N~ 50/60Hz		•	796x530	2.733,00
	E7/KTE2BBMK	K						•







**F** - Piastra in acciaio semi-dolce - Semi-mild steel plate - Halbweiche Stahlplatte - Plaque en acier demi-doux - Plancha de acero semi-suave

**K** - Piastra conforme a normativa CE 1935/2004-MOCA - Plate in compliance with EC 1935/2004 Regulation-FCM - LKM-Platte konform mit CE 1935/2004 - Plaque en ligne avec le règlement CE 1935/2004-MCDA - Plancha conforme al reglamento CE 1935/2004-MOCA

# Easy700

## FRY-TOP ELETTRICO

ELECTRIC GRIDDLE PLATES - ELEKTRO GRILLPLATTEN - FRY-TOP ÉLECTRIQUE - FRY-TOP ELÉCTRICOS

	Model	F K	 (A x B x C) mm	kW	UE	Extra UE	Dim.cooking plate mm.	€
	E7/KTE1BAL	F	400x700x850h	5,4 400V3N~ 50/60Hz		•	396x530	2.204,00
	E7/KTE1BALK	K						•
	E7/KTE1BAR	F	400x700x850h	5,4 400V3N~ 50/60Hz		•	396x530	2.255,00
	E7/KTE1BARK	K						•
	E7/FTE2BAL	F	700x700x850h	10,8 400V3N~ 50/60Hz	•	•	696x530	2.868,00
	E7/FTE2BALK	K						•
	E7/KTE2BAL	F	800x700x850h	10,8 400V3N~ 50/60Hz	•	•	796x530	2.926,00
	E7/KTE2BALK	K						•
	E7/FTE2BAR	F	700x700x850h	10,8 400V3N~ 50/60Hz	•	•	696x530	3.080,00
	E7/FTE2BARK	K						•
	E7/KTE2BAR	F	800x700x850h	10,8 400V3N~ 50/60Hz	•	•	796x530	3.144,00
	E7/KTE2BARK	K						•
	E7/FTE2BAM	F	700x700x850h	10,8 400V3N~ 50/60Hz	•	•	696x530	2.964,00
	E7/FTE2BAMK	K						•
	E7/KTE2BAM	F	800x700x850h	10,8 400V3N~ 50/60Hz	•	•	796x530	3.026,00
	E7/KTE2BAMK	K						•

EASY700

F - Piastra in acciaio semi-dolce - Semi-mild steel plate - Halbweiche Stahlplatte - Plaque en acier demi-doux - Plancha de acero semi-suave

K - Piastra conforme a normativa CE 1935/2004-MOCA - Plate in compliance with EC 1935/2004 Regulation-FCM - LKM-Platte konform mit CE 1935/2004 - Plaque en ligne avec le règlement CE 1935/2004-MCDA - Plancha conforme al reglamento CE 1935/2004-MOCA



### ACCESSORI- ACCESSORIES- ZUBEHÖRE- ACCESSOIRES- ACCESORIOS

	E7/CH035	mm.350	Anta - Door - Tür - Porte - Puerta	172,00
	E7/CH040	mm.400	Anta - Door - Tür - Porte - Puerta	181,00

## ELEMENTI NEUTRI

NEUTRAL UNITS- ARBEITSELEMENTE - ELEMENTS NEUTRES - MUEBLES  
NEUTROS

EASY700

	Model	 (A x B x C) mm		€
	E7/ENN1BB	350x700x275h		<b>636,00</b>
	E7/ENN1CB	350x700x275h	con 1 cassetto - with 1 drawer - mit 1 Schublade - avec 1 tiroir - con 1 cajón	<b>1.094,00</b>
	E7/KNN1BB	400x700x275h		<b>670,00</b>
	E7/KNN1CB	400x700x275h	con 1 cassetto GN 1/1 - with 1 drawer GN 1/1- mit 1 Schublade GN 1/1 - avec 1 tiroir GN 1/1 - con 1 cajón GN 1/1	<b>1.132,00</b>
	E7/ENN2BB	700x700x275h		<b>798,00</b>
	E7/ENN2CB	700x700x275h	con 1 cassetto - with 1 drawer - mit 1 Schublade - avec 1 tiroir - con 1 cajón	<b>1.297,00</b>
	E7/KNN2BB	800x700x275h		<b>843,00</b>
	E7/KNN2CB	800x700x275h	con 1 cassetto GN 2/1 - with 1 drawer GN 2/1- mit 1 Schublade GN 2/1 - avec 1 tiroir GN 2/1 - con 1 cajón GN 2/1	<b>1.342,00</b>
	E7/ENN1BA	350x700x850h		<b>843,00</b>
	E7/ENN1CA	350x700x850h	con 1 cassetto - with 1 drawer - mit 1 Schublade - avec 1 tiroir - con 1 cajón	<b>1.301,00</b>
	E7/KNN1BA	400x700x850h		<b>890,00</b>
	E7/KNN1CA	400x700x850h	con 1 cassetto GN 1/1 - with 1 drawer GN 1/1- mit 1 Schublade GN 1/1 - avec 1 tiroir GN 1/1 - con 1 cajón GN 1/1	<b>1.346,00</b>
	E7/ENN2BA	700x700x850h		<b>1.018,00</b>
	E7/ENN2CA	700x700x850h	con 1 cassetto - with 1 drawer - mit 1 Schublade - avec 1 tiroir - con 1 cajón	<b>1.518,00</b>
	E7/KNN2BA	800x700x850h		<b>1.064,00</b>
	E7/KNN2CA	800x700x850h	con 1 cassetto GN 2/1 - with 1 drawer GN 2/1- mit 1 Schublade GN 2/1 - avec 1 tiroir GN 2/1 - con 1 cajón GN 2/1	<b>1.566,00</b>

## ACCESSORI- ACCESSORIES- ZUBEHÖRE- ACCESSOIRES- ACCESORIOS

	E7/CH035	mm.350	Anta - Door - Tür - Porte - Puerta	<b>172,00</b>
	E7/CH040	mm.400	Anta - Door - Tür - Porte - Puerta	<b>181,00</b>

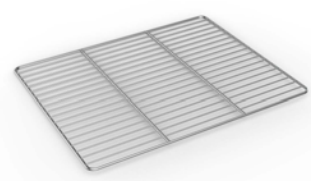
	Model	 (A x B x C) mm	Description	€
<b>ACCESSORI- ACCESSORIES- ZUBEHÖRE- ACCESSOIRES- ACCESORIOS</b>				
	<b>E7/CH035</b>	mm.350	Anta - Door - Tür - Porte - Puerta	<b>172,00</b>
	<b>E7/CH040</b>	mm.400	Anta - Door - Tür - Porte - Puerta	<b>181,00</b>
	<b>E7/EX035</b>	350x50x170h	Prolunga camino - Flue extentions	<b>156,00</b>
	<b>E7/EX040</b>	400x50x170h	Prolunga camino - Flue extentions	<b>166,00</b>
	<b>E7/EX070</b>	700x50x170h	Prolunga camino - Flue extentions	<b>227,00</b>
	<b>E7/EX080</b>	800x50x170h	Prolunga camino - Flue extentions	<b>245,00</b>
	<b>E7/EX105</b>	1.050x50x170h	Prolunga camino - Flue extentions	<b>299,00</b>
	<b>E7/EX120</b>	1.200x50x170h	Prolunga camino - Flue extentions	<b>324,00</b>
	<b>15/99901029</b>		Riduzione per griglia Reduction grid for grid Reduzierrost für Rost Grille de reduction pour support poele Rejilla reductore para parrilla	<b>50,00</b>
	<b>21/99600079</b>	535x450	Griglia cromata interna forno - Chromed grid for oven <b>Mod. FO/FE</b>	<b>66,00</b>
	<b>21/GX2/1</b>	530x650	Griglia cromata interna forno - Chromed grid for oven <b>Mod. LO/LE</b>	<b>75,00</b>
	<b>21/99600089</b>	885x450	Griglia cromata interna forno - Chromed grid for oven <b>Mod. FM</b>	<b>110,00</b>
	<b>SET4RUOTE</b> <b>2 X 63/99000143</b> <b>2 X 63/99000144</b>	∅ mm.100	Set nr.4 ruote ∅ mm.100 (nr.2 con freno) Set of nr.4 castors ∅ mm.100 (nr.2 with breaks) Set von nr.4 Räder ∅ mm.100 (nr.2 mit Bremse) Set de 4 roues ∅ mm.100 (nr.2 avec freins) Set de 4 ruedas ∅ mm.100 (nr.1 con frenos)	<b>400,00</b>
	<b>COP.PIE</b>	H. mm.110	Zoccolo inox copertura piedi Cover for feet in stainless steel Fußbende für Füße aus Edelstahl Couverture pour les pieds en acier inox Sueco para patas en acero inoxidable	<b>292,00</b>  <small>AL METRO LINEARE - FOR LINEAR METER - FÜR LINEARMETER - AU METRE LINÉAIRE - POR METRO LINEAR</small>



# 700 farchy 700





## CUCINE GAS











GAS RANGES - GASHERDE - CUISINIÈRES GAZ - COCINAS GAS

	Model		kW	Burners	Oven	€
Versione da banco - Bench model - Auf Tischmodell - Modèle à poser - Modelo de sobremesa						
	<b>L7/KUPG2BB.2M</b>	400x700x275h	9,0			<b>1.463,00</b>
	<b>L7/KUPG2BB.1M1G</b>	400x700x275h	12,0			<b>1.477,00</b>
	<b>L7/KUPG2BB.2G</b>	400x700x275h	15,0			<b>1.515,00</b>
	<b>L7/KUPG4BB.4M</b>	800x700x275h	18,0			<b>2.281,00</b>
	<b>L7/KUPG4BB.2M2G</b>	800x700x275h	24,0			<b>2.309,00</b>
	<b>L7/KUPG4BB.4G</b>	800x700x275h	30,0			<b>2.386,00</b>
	<b>L7/KUPG6BB.6M</b>	1.200x700x275h	27,0			<b>3.101,00</b>
	<b>L7/KUPG6BB.3M3G</b>	1.200x700x275h	36,0			<b>3.143,00</b>
	<b>L7/KUPG6BB.6G</b>	1.200x700x275h	45,0			<b>3.257,00</b>

LADY700

## CUCINE GAS GAS RANGES - GASHERDE - CUISINIÈRES GAZ - COCINAS GAS

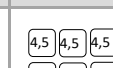
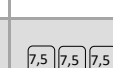

	Model	 (A x B x C) mm	kW	Burners	Oven	€
	Modello su vano a giorno - Model on open cabinet - Modell mit offenem Unterbau - Modèle sur meuble ouvert - Modelo abierto					
	L7/KUPG2BA.2M	400x700x850h	9,0			1.714,00
	L7/KUPG2BA.1M1G	400x700x850h	12,0			1.729,00
	L7/KUPG2BA.2G	400x700x850h	15,0			1.768,00
	L7/KUPG4BA.4M	800x700x850h	18,0			2.592,00
	L7/KUPG4BA.2M2G	800x700x850h	24,0			2.620,00
	L7/KUPG4BA.4G	800x700x850h	30,0			2.696,00
	L7/KUPG6BA.6M	1.200x700x850h	27,0			3.432,00
	L7/KUPG6BA.3M3G	1.200x700x850h	36,0			3.473,00
	L7/KUPG6BA.6G	1.200x700x850h	45,0			3.588,00







LADY700

	Model	 (A x B x C) mm	kW	Burners	Oven	€
	L7/KUPG4LO.4M	800x700x850h	25,9			4.173,00
	L7/KUPG4LO.2M2G	800x700x850h	31,9			4.199,00
	L7/KUPG4LO.4G	800x700x850h	37,9			4.276,00
	L7/KUPG4LE.4M	800x700x850h	18,0 5,48			4.359,00
	L7/KUPG4LE.2M2G	800x700x850h	24,0 5,48			4.387,00
	L7/KUPG4LE.4G	800x700x850h	30,0 5,48			4.464,00
	L7/KUPG6LN.6M	1.200x700x850h	34,9			5.259,00
	L7/KUPG6LN.3M3G	1.200x700x850h	43,9			5.301,00
	L7/KUPG6LN.6G	1.200x700x850h	52,9			5.415,00
	L7/KUPG6LE.6M	1.200x700x850h	27,0 5,48			5.450,00
	L7/KUPG6LE.3M3G	1.200x700x850h	36,0 5,48			5.492,00
	L7/KUPG6LE.6G	1.200x700x850h	45,0 5,48			5.606,00
	L7/KUPG6FM.6M	1.200x700x850h	39,0			5.598,00
	L7/KUPG6FM.3M3G	1.200x700x850h	48,0			5.641,00
	L7/KUPG6FM.6G	1.200x700x850h	57,0			5.755,00

Accessori in dotazione nr.1 griglia interna forno e nr. 1 riduzione fuoco - Accessories included nr.1 internal grid for oven and nr.1 reduction for burner - Zubehöre inbegriffen nr.1 Rost für Ofen und nr.1 Reduzierrost für Brenner - Accessoires inclus nr.1 grille pour four et nr.1 grille de réduction pour brûleur - Accesorios incluidos nr.1 parilla para horno y nr.1 rejilla reductora para quemador

**CUCINE WOK A GAS**

 GAS WOK RANGES - WOK GASHERDE - CUISINIÈRES WOK À GAZ -  
 COCINAS WOK A GAS

	Model	 (A x B x C) mm	kW	Burners	€
	Bruciatori a scelta tra: - Burners available on request: - Brennern auf Anfrage von: - Brûleurs sur demande: - Quemadores bajo pedido:				
		Mod. "C" kW 9,5 - Ø mm.175			
		Mod. "T" kW 14,0 - Ø mm.175			
Versione da banco - Bench model - Auf Tischmodell - Modèle à poser - Modelo de sobremesa					
	<b>L7/CC/01.BB</b>	400x700x275h	14,0	14	<b>2.200,00</b>
Modello su vano a giorno - Model on open cabinet - Modell mit offenem Unterbau - Modèle sur meuble ouvert - Modelo abierto					
	<b>L7/CC/01.BA</b>	400x700x850h	14,0	14	<b>2.677,00</b>
<b>ACCESSORI- ACCESSORIES- ZUBEHÖRE- ACCESSOIRES- ACCESORIOS</b>					
	<b>L7/CH040</b>	mm.400	Anta - Door - Tür - Porte - Puerta		<b>205,00</b>

## CUCINE TUTTAPIASTRA

SOLID TOPS GAS RANGES - GLÜHLPLATTENHERDE - CUISINIÈRES PLAQUE COUP DE FEU À GAZ - PLACA RADIANTE

LADY700

	Model		kW	Burners	Oven	€
	L7/TPG2BB.1M1G	800x700x275h	16,5			2.795,00
	L7/TPG2BA.1M1G	800x700x850h	16,5			3.298,00
	L7/TPG2LO.1M1G	800x700x850h	24,4		 GN 2/1 mm.685x550x310h	4.761,00
	L7/TPG2LE.1M1G	800x700x850h	16,5 5,48		 400V3N~ 50/60Hz GN 2/1 mm.685x550x310h	4.851,00
	L7/TPG4BB	800x700x275h	9,0			2.629,00
	L7/TPG4BA	800x700x850h	9,0			2.940,00
	L7/TPG4LO	800x700x850h	16,9		 GN 2/1 mm.685x550x310h	4.449,00
	L7/TPG4LE	800x700x850h	9,0 5,48		 400V3N~ 50/60Hz GN 2/1 mm.685x550x310h	4.566,00

## CUCINE TUTTAPIASTRA

SOLID TOPS GAS RANGES - GLÜHLPLATTENHERDE - CUISINIÈRES PLAQUE COUP  
DE FEU À GAZ - PLACA RADIANTE

	Model	 (A x B x C) mm	kW	Burners	Oven	€
	L7/TPG6BB.2M2G	1.200x700x275h	28,5			4.114,00
	L7/TPG6BA.2M2G	1.200x700x850h	28,5			4.401,00
	L7/TPG6LN.2M2G	1.200x700x850h	36,4		 GN 2/1 mm.685x550x310h	6.084,00
	L7/TPG6LE.2M2G	1.200x700x850h	28,5 5,48		 400V3N~ 50/60Hz GN 2/1 mm.685x550x310h	6.233,00
	L7/TPG6BB.1M1G	1.200x700x275h	21,0			4.055,00
	L7/TPG6BA.1M1G	1.200x700x850h	21,0			4.345,00
	L7/TPG6LN.1M1G	1.200x700x850h	28,9		 GN 2/1 mm.685x550x310h	6.057,00
	L7/TPG6LE.1M1G	1.200x700x850h	21,0 5,48		 400V3N~ 50/60Hz GN 2/1 mm.685x550x310h	6.226,00

**CUCINE ELETTRICHE**

ELECTRIC RANGES - ELEKTROHERDE - CUISINIÈRES ELECTRIQUES - COCINAS ELÉCTRICAS

**LADY700**

	Model	 (A x B x C) mm	kW	Burners	Oven	€
Versione da banco - Bench model - Aufschmodell - Modèle à poser - Modelo de sobremesa						
	L7/CUET2BB	400x700x275h	⚡ 5,2 400V3N~ 50/60Hz	⊙ 2,6 ⊙ 2,6 Ø mm.220		1.213,00
	L7/CUET4BB	800x700x275h	⚡ 10,4 400V3N~ 50/60Hz	⊙ 2,6 ⊙ 2,6 ⊙ 2,6 ⊙ 2,6 Ø mm.220		1.756,00
	L7/CUET6BB	1.200x700x275h	⚡ 15,6 400V3N~ 50/60Hz	⊙ 2,6 ⊙ 2,6 ⊙ 2,6 ⊙ 2,6 ⊙ 2,6 ⊙ 2,6 Ø mm.220		2.363,00
Modello su vano a giorno - Model on open cabinet - Modell mit offenem Unterbau - Modèle sur meuble ouvert - Modelo abierto						
	L7/CUET2BA	400x700x850h	⚡ 5,2 400V3N~ 50/60Hz	⊙ 2,6 ⊙ 2,6 Ø mm.220		1.521,00
	L7/CUET4BA	800x700x850h	⚡ 10,4 400V3N~ 50/60Hz	⊙ 2,6 ⊙ 2,6 ⊙ 2,6 ⊙ 2,6 Ø mm.220		2.215,00
	L7/CUET6BA	1.200x700x850h	⚡ 15,6 400V3N~ 50/60Hz	⊙ 2,6 ⊙ 2,6 ⊙ 2,6 ⊙ 2,6 ⊙ 2,6 ⊙ 2,6 Ø mm.220		2.909,00
Modello con forno elettrico / Model with electric oven / Modell mit Elektro-Backofen / Modèle avec four électrique / Modelo con horno eléctrico						
	L7/CUET4LE	800x700x850h	⚡ 15,88 400V3N~ 50/60Hz	⊙ 2,6 ⊙ 2,6 ⊙ 2,6 ⊙ 2,6 Ø mm.220	 kW 5,48 400V3N~ 50/60Hz GN 2/1 mm.685x550x310h	3.988,00
	L7/CUET6LE	1.200x700x850h	⚡ 21,08 400V3N~ 50/60Hz	⊙ 2,6 ⊙ 2,6 ⊙ 2,6 ⊙ 2,6 ⊙ 2,6 ⊙ 2,6 Ø mm.220	 kW 5,48 400V3N~ 50/60Hz GN 2/1 mm.685x550x310h	4.915,00

**CUCINE ELETTRICHE VETROCERAMICA**

ELECTRIC GLASS CERAMIC RANGES - GLASKERAMIK ELEKTROHERDE -

CUISINIÈRES ÉLECTRIQUES VITROCÉRAMIQUE - COCINAS ELÉCTRICAS EN

VITROCERÁMICA

	<b>Model</b>	 (A x B x C) mm	<b>kW</b>	<b>Burners</b>	<b>Oven</b>	<b>€</b>
Versione da banco - Bench model - Aufschmodell - Modèle à poser - Modelo de sobremesa						
	<b>L7/CVE2BB</b>	400x700x275h	⚡ 5,0  400V3N~ 50/60Hz			<b>2.301,00</b>
	<b>L7/CVE4BB</b>	800x700x275h	⚡ 10,0  400V3N~ 50/60Hz			<b>3.991,00</b>
Modello su vano a giorno - Model on open cabinet - Modell mit offenem Unterbau - Modèle sur meuble ouvert - Modelo abierto						
	<b>L7/CVE2BA</b>	400x700x850h	⚡ 5,0  400V3N~ 50/60Hz			<b>2.666,00</b>
	<b>L7/CVE4BA</b>	800x700x850h	⚡ 10,0  400V3N~ 50/60Hz			<b>4.479,00</b>
Modello con forno elettrico - Model with electric oven - Modell mit Elektro-Backofen - Modèle avec four électrique - Modelo con horno eléctrico						
	<b>L7/CVE4LE</b>	800x700x850h	⚡ 15,48  400V3N~ 50/60Hz		 400V3N~ 50/60Hz  GN 2/1 mm.685x550x310h	<b>6.229,00</b>





**CUCINE A INDUZIONE**

 INDUCTION RANGES - INDUKTIONHERDE - CUISINIÈRES À INDUCTION -  
 COCINAS ELÉCTRICAS A INDUCCIÓN

	Model	 (A x B x C) mm	kW	Burners	Oven	€
	Versione da banco - Bench model - Aufschmodell - Modèle à poser - Modelo de sobremesa					
	L7/CUI2BB.L	400x700x275h	⚡ 7,0 400V3N~ 50/60Hz	⊖3,5 ⊖3,5		7.963,00
	L7/CUI4BB.L	800x700x275h	⚡ 14,0 400V3N~ 50/60Hz	⊖3,5 ⊖3,5 ⊖3,5 ⊖3,5		14.245,00
Modello su vano a giorno - Model on open cabinet - Modell mit offenem Unterbau - Modèle sur meuble ouvert - Modelo abierto						
	L7/CUI2BA.L	400x700x850h	⚡ 7,0 400V3N~ 50/60Hz	⊖3,5 ⊖3,5		8.306,00
	L7/CUI4BA.L	800x700x850h	⚡ 14,0 400V3N~ 50/60Hz	⊖3,5 ⊖3,5 ⊖3,5 ⊖3,5		14.721,00

**LADY700**
**SCALDAPATATE**

CHIP SCUTTLE - KARTOFFELWÄRMER - CHAUFFE FRITES - CALIENTA PATATAS

	Model	 (A x B x C) mm	kW	Cap.	€
		L7/SPE40BB	400x700x275h	⚡ 1,0 230V~ 50/60Hz	GN 1/1 <span style="border: 1px solid black; border-radius: 10px; padding: 2px;">1/1</span>
	L7/SPE40BA	400x700x850h	⚡ 1,0 230V~ 50/60Hz	GN 1/1 <span style="border: 1px solid black; border-radius: 10px; padding: 2px;">1/1</span>	2.067,00

**FRIGGITRICI A GAS**

GAS FRYERS - GAS FRITTEUSEN - FRITEUSES GAZ - FREIDORAS A GAS













	Model	 (A x B x C) mm	kW	Baskets included	Lt.	€
Scambiatori di calore INTERNI - INTERNAL heat exchangers - Wärmetauschbrenner INNERHALB des Beckens - Échangeurs de chaleur INTERNES à la cuve - Intercambiadores de calor EN el tanque						
	L7/FLG1V13	400x700x850h	11,2		13	3.313,00
	L7/FLG1V17	400x700x850h	16,5		17	3.721,00
	L7/FLG2V8	400x700x850h	11,6		8+8	5.015,00
	L7/FLG2V13	800x700x850h	22,4		13+13	5.730,00
	L7/FLG2V17	800x700x850h	33,0		17+17	6.494,00
Cestelli, coperchio e n.1 vasca raccogli olio in dotazione - Equipped with baskets, lid and n.1 s/s oil draining tank - Inkl. Körbe, Deckel und n.1 Ölauffangbecken aus Edelstahl - Paniers, couvercle et n.1 bac de récupération huile en acier inoxydable inclus - Cestas, la tapa y n.1 barreño recoge aceite en acero inoxidable en dotación						
<b>ACCESSORI- ACCESSORIES- ZUBEHÖRE- ACCESSOIRES- ACCESORIOS</b>						
	21/99600132	109x300x120h	cestello 1/2 per vasca cap.Lt 13 Mod. FLG/FRG/FRE - basket 1/2 for tank cap. lt.13 Mod. FLG/FRG/FRE			107,00
	21/99600133	140x300x120h	cestello 1/2 per vasca cap.Lt 17 Mod. FLG/FRG/FRE - basket 1/2 for tank cap. lt.17 Mod. FLG/FRG/FRE			110,00
	21/99600131	220x300x120h	cestello 1/1 per vasca cap.Lt 13 Mod. FLG/FRG/FRE - basket 1/1 for tank cap. lt.13 Mod. FLG/FRG/FRE			118,00
	21/99600134	290x300x120h	cestello 1/1 per vasca cap.Lt 17 Mod. FLG/FRG/FRE - basket 1/1 for tank cap. lt.17 Mod. FLG/FRG/FRE			121,00
	21/99600130	120x300x120h	cestello per vasca cap.Lt 8 Mod. FLG/FRE - basket for tank cap. lt.8 Mod. FLG/FRE			110,00
	WD/99600001		vasca raccogli olio supplementare - additional oil draining tank			246,00

LADY700



## FRIGGITRICI A GAS GAS FRYERS - GAS FRITTEUSEN - FRITEUSES GAZ - FREIDORAS A GAS

LADY700

	Model	 (A x B x C) mm	kW	Baskets included	Lt.	€
Scambiatori di calore ESTERNI, vasca pulita - EXTERNAL heat exchangers, clean tank - Brenner an der AUßENSEITE des Beckens - Échangeurs de chaleur EXTÉRIEUR à la cuve - Intercambiadores de calor EXTERNOS a la cuba						
	L7/FRG1V13	400x700x850h	12,0		13	3.737,00
	L7/FRG1V17	400x700x850h	16,0		17	3.920,00
	L7/FRG2V13	800x700x850h	24,0		13+13	6.358,00
	L7/FRG2V17	800x700x850h	32,0		17+17	6.616,00

Cestelli, coperchio e n.1 vasca raccogli olio in dotazione - Equipped with baskets, lid and n.1 s/s oil draining tank - Inkl. Körbe, Deckel und n.1 Ölauffangbecken aus Edelstahl - Paniers, couvercle et n.1 bac de récupération huile en acier inoxydable inclus - Cestas, la tapa y n.1 barreño recoge aceite en acero inoxidable en dotación

### ACCESSORI- ACCESSORIES- ZUBEHÖRE- ACCESSOIRES- ACCESORIOS

	21/99600132	109x300x120h	cestello 1/2 per vasca cap.Lt 13 Mod. FLG/FRG/FRE - basket 1/2 for tank cap. Lt.13 Mod. FLG/FRG/FRE	107,00
	21/99600133	140x300x120h	cestello 1/2 per vasca cap.Lt 17 Mod. FLG/FRG/FRE - basket 1/2 for tank cap. Lt.17 Mod. FLG/FRG/FRE	110,00
	21/99600131	220x300x120h	cestello 1/1 per vasca cap.Lt 13 Mod. FLG/FRG/FRE - basket 1/1 for tank cap. Lt.13 Mod. FLG/FRG/FRE	118,00
	21/99600134	290x300x120h	cestello 1/1 per vasca cap.Lt 17 Mod. FLG/FRG/FRE - basket 1/1 for tank cap. Lt.17 Mod. FLG/FRG/FRE	121,00
	21/99600130	120x300x120h	cestello per vasca cap.Lt 8 Mod. FLG/FRE - basket for tank cap. Lt.8 Mod. FLG/FRE	110,00
	WD/99600001		vasca raccogli olio supplementare - additional oil draining tank	246,00

## FRIGGITRICI ELETTRICHE ELECTRIC FRYERS - ELEKTRO FRITTEUSEN - FRITEUSES ÉLECTRIQUE - FREIDORAS ELÉCTRICAS









		Model	 (A x B x C) mm	kW	Baskets included	Lt.	€
Resistenze rotanti in vasca - Rotating resistors in the tank - Heizkörper mit Dreh-System in Öl getaucht - Résistances immergées rotatives aux bacs - Resistencias rodantes en el tanque							
		L7/FRE1V13	400x700x850h	12,0 400V3N~ 50/60Hz		13	2.915,00
		L7/FRE1V17	400x700x850h	16,5 400V3N~ 50/60Hz		17	3.120,00
		L7/FRE2V8	400x700x850h	14,0 400V3N~ 50/60Hz		8+8	3.837,00
		L7/FRE2V13	800x700x850h	24,0 400V3N~ 50/60Hz		13+13	4.692,00
		L7/FRE2V17	800x700x850h	33,0 400V3N~ 50/60Hz		17+17	4.819,00
Cestelli, coperchio e n.1 vasca raccogli olio in dotazione - Equipped with baskets, lid and n.1 s/s oil draining tank - Inkl. Körbe, Deckel und n.1 Ölauffangbecken aus Edelstahl - Paniers, couvercle et n.1 bac de récupération huile en acier inoxydable inclus - Cestas, la tapa y n.1 barreño recoge aceite en acero inoxidable en dotación							
<b>ACCESSORI- ACCESSORIES- ZUBEHÖRE- ACCESSOIRES- ACCESORIOS</b>							
	21/99600132	109x300x120h	cestello 1/2 per vasca cap.Lt 13 Mod. FLG/FRG/FRE - basket 1/2 for tank cap. lt.13 Mod. FLG/FRG/FRE	107,00			
	21/99600133	140x300x120h	cestello 1/2 per vasca cap.Lt 17 Mod. FLG/FRG/FRE - basket 1/2 for tank cap. lt.17 Mod. FLG/FRG/FRE	110,00			
	21/99600131	220x300x120h	cestello 1/1 per vasca cap.Lt 13 Mod. FLG/FRG/FRE - basket 1/1 for tank cap. lt.13 Mod. FLG/FRG/FRE	118,00			
	21/99600134	290x300x120h	cestello 1/1 per vasca cap.Lt 17 Mod. FLG/FRG/FRE - basket 1/1 for tank cap. lt.17 Mod. FLG/FRG/FRE	121,00			
	21/99600130	120x300x120h	cestello per vasca cap.Lt 8 Mod. FLG/FRE - basket for tank cap. lt.8 Mod. FLG/FRE	110,00			
	WD/99600001		vasca raccogli olio supplementare - additional oil draining tank	246,00			

LADY700

## CUOCIPASTA

PASTA COOKERS - NUDELKOCHER - CUISEUR À PÂTES - CUECE-PASTAS

LADY700

	Model	 (A x B x C) mm	kW	Lt.	Cap.	€
Versione gas - Gas model - Gasmmodell - Modèle à gaz - Modelo gas						
	L7/KPG1V40	400x700x850h	 11,0	28	<div style="border: 1px solid black; border-radius: 10px; padding: 2px 5px; display: inline-block;">2/3</div>	3.163,00
	L7/KPG2V80	800x700x850h	 22,0	28+28	<div style="display: flex; gap: 5px;"> <div style="border: 1px solid black; border-radius: 10px; padding: 2px 5px;">2/3</div> <div style="border: 1px solid black; border-radius: 10px; padding: 2px 5px;">2/3</div> </div>	5.277,00
Cestelli e coperchi non in dotazione - Baskets and lids are not included - Körbe und Deckeln im Preis nicht imbegriffen - Paniers et couvercles pas compris dans le prix - Cestas y la tapas no incluidas en el precio						
Versione elettrica - Electric model - Elektromodell - Modèle électrique - Modelo eléctricos						
	L7/KPE1V40	400x700x850h	 7,0  400V3N~ 50/60Hz	28	<div style="border: 1px solid black; border-radius: 10px; padding: 2px 5px; display: inline-block;">2/3</div>	3.482,00
	L7/KPE2V80	800x700x850h	 14,0  400V3N~ 50/60Hz	28+28	<div style="display: flex; gap: 5px;"> <div style="border: 1px solid black; border-radius: 10px; padding: 2px 5px;">2/3</div> <div style="border: 1px solid black; border-radius: 10px; padding: 2px 5px;">2/3</div> </div>	5.796,00
Cestelli e coperchi non in dotazione - Baskets and lids are not included - Körbe und Deckeln im Preis nicht imbegriffen - Paniers et couvercles pas compris dans le prix - Cestas y la tapas no incluidas en el precio						

**ACCESSORI PER CUOCIPASTA**

 ACCESSORIES FOR PASTA COOKERS - ZUBEHÖRE FÜR NUDELKOCHER - ACCESSOIRES  
 POUR CUISEUR À PÂTES - ACCESORIOS PARA CUECE-PASTAS

	Model	 (A x B x C) mm	Description	€
<b>ACCESSORI- ACCESSORIES- ZUBEHÖRE- ACCESSOIRES- ACCESORIOS</b>				
	<b>SET 700CESA</b> 2 X 21/99900147 2 X 21/99900148	nr.4 x 143x163x215h	nr.4 cestelli inox 1/6 nr.4 s/s baskets 1/6	<b>528,00</b>
	<b>SET 700CESB</b> 2 X 21/99900148 1 X 21/99900000	nr.2 x 143x163x215h + nr.1 x 290x143x215h	nr.2 cestelli inox 1/6 + nr.1 cestello inox 1/3 con un manico nr.2 s/s baskets 1/6 + nr.1 s/s basket 1/3 with one handle	<b>421,00</b>
	<b>SET 700CESC</b> 2 X 21/99900000	nr.2 x 290x143x215h	nr.2 cestelli inox 1/3 con un manico nr.2 s/s baskets 1/3 with one handle	<b>314,00</b>
	<b>SET 700CESD</b> 1 X 21/99900159	nr.1 x 325x290x215h	nr.1 cestello inox 2/3 con due manici nr.1 s/s basket 2/3 with two handles	<b>219,00</b>
	<b>SET 700CESE</b> 2 X 21/99900081	nr.2 x 288x163x215h	nr.2 cestelli inox 1/3 con due manici nr.2 s/s baskets 1/3 with two handles	<b>336,00</b>
	<b>SET 700CESF</b> 1 X 21/99900147 1 X 21/99900148 1 X 21/99900081	nr.2 x 143x163x215h + nr.1 x 288x163x215h	nr.2 cestelli inox 1/6 + nr.1 cestello inox 1/3 con due manici nr.2 s/s baskets 1/6 + nr.1 s/s basket 1/3 with two handles	<b>432,00</b>
	21/99900147	143x163x215h	cestello 1/6 con manico a destra s/s basket 1/6 with right-hand side handle	<b>132,00</b>
	21/99900148	143x163x215h	cestello inox 1/6 con manico a sinistra s/s basket 1/6 with left-hand side handle	<b>132,00</b>
	21/99900000	290x143x215h	cestello inox 1/3 con un manico s/s basket 1/3 with one handle	<b>157,00</b>
	21/99900081	288x163x215h	cestello inox 1/3 con due manici s/s basket 1/3 with two handles	<b>168,00</b>
	23/99600128	380x270	coperchio inox per vasca lt. 28 s/s 304 lid for tank lt. 28	<b>103,00</b>
	21/99900179	d. 145x200h	cestello tondo d. 145 mm - round s/s basket d. 145 mm	<b>136,00</b>
	<b>SET700CESG</b> 4 X 21/99900179	nr. 4 x d. 145x200h	nr. 4 cestelli tondi d. 145 mm - nr. 4 round s/s baskets d. 145 mm	<b>544,00</b>
	23/99909200		supporto cestelli tondi per vasca GN 1/1 - support for round baskets - tank GN 1/1	<b>112,00</b>

**CUOCIPASTA ELETTRICO FASTPASTA**  
 ELECTRIC PASTA COOKERS FASTPASTA - ELEKTRO NUDELKOCHER FASTPASTA -  
 CUISEUR À PÂTES FASTPASTA ÉLECTRIQUE - CUECE-PASTAS FASTPASTA  
 ELÉCTRICOS

	<b>Model</b>		<b>kW</b>	<b>Set baskets included</b>	<b>€</b>
Con nr.2 sollevamenti per vasca - With nr.2 lifters for each tank - Mit nr.2 Körbeheber für jedes Becken - Avec nr.2 relevages pour chaque cuve - Con nr.2 levantamientos para cada cuba					
	<b>L7/CPE1V-1FP-A</b>	500x700x850h	⚡ 7,4  400V3N~ 50/60Hz	  Cap. Lt. 28	<b>8.065,00</b>
Con nr.4 sollevamenti per vasca - With nr.4 lifters for each tank - Mit nr.4 Körbeheber für jedes Becken - Avec nr.4 relevages pour chaque cuve - Con nr.4 levantamientos para cada cuba					
	<b>L7/CPE1V-2FP-C</b>	600x700x850h	⚡ 7,8  400V3N~ 50/60Hz	  Cap. Lt. 28	<b>11.837,00</b>
Con nr.2 sollevamenti per vasca - With nr.2 lifters for each tank - Mit nr.2 Körbeheber für jedes Becken - Avec nr.2 relevages pour chaque cuve - Con nr.2 levantamientos para cada cuba					
	<b>L7/CPE2V-2FP-AA</b>	1.000x700x850h	⚡ 14,8  400V3N~ 50/60Hz	  Cap. Lt. 28+28	<b>14.053,00</b>
Con nr.4 sollevamenti per vasca - With nr.4 lifters for each tank - Mit nr.4 Körbeheber für jedes Becken - Avec nr.4 relevages pour chaque cuve - Con nr.4 levantamientos para cada cuba					
	<b>L7/CPE2V-4FP-CC</b>	1.200x700x850h	⚡ 15,6  400V3N~ 50/60Hz	  Cap. Lt. 28+28	<b>21.450,00</b>







LADY700

**CUOCIPASTA ELETTRICO FASTPASTA**







ELECTRIC PASTA COOKERS FASTPASTA - ELEKTRO NUDELKOCHER FASTPASTA -

CUISEUR À PÂTES FASTPASTA ÉLECTRIQUE - CUECE-PASTAS FASTPASTA

ELÉCTRICOS



	Model		Description	€
<b>ACCESSORI- ACCESSORIES- ZUBEHÖRE- ACCESSOIRES- ACCESORIOS</b>				
	<b>SET 700CESA</b> 2 X 21/99900147 2 X 21/99900148	nr.4 x 143x163x215h	nr.4 cestelli inox 1/6 nr.4 s/s baskets 1/6	<b>528,00</b>
	<b>SET 700CESE</b> 2 X 21/99900081	nr.2 x 288x163x215h	nr.2 cestelli inox 1/3 con due manici nr.2 s/s baskets 1/3 with two handles	<b>336,00</b>
	<b>SET 700CESF</b> 1 X 21/99900147 1 X 21/99900148 1 X 21/99900081	nr.2 x 143x163x215h + nr.1 x 288x163x215h	nr.2 cestelli inox 1/6 + nr.1 cestello inox 1/3 con due manici nr.2 s/s baskets 1/6 + nr.1 s/s basket 1/3 with two handles	<b>432,00</b>
	21/99900147	143x163x215h	cestello 1/6 con manico a destra s/s basket 1/6 with right-hand side handle	<b>132,00</b>
	21/99900148	143x163x215h	cestello inox 1/6 con manico a sinistra s/s basket 1/6 with left-hand side handle	<b>132,00</b>
	21/99900081	288x163x215h	cestello inox 1/3 con due manici s/s basket 1/3 with two handles	<b>168,00</b>
	WA/99908659	155x304xØ6	Supporto per sollevatore per 2 GN 1/6 Lift support for 2 GN 1/6 Aufasatz für Hebevorrichtung für 2 GN 1/6 Support pour éleveur pour 2 GN 1/6 Suporte para levantador para 2 GN 1/6	<b>83,00</b>
	CPRAM		Riempimento e rabbocco automatico acqua in vasca Automatic water re-filling in tank Automatisches Füllen und Nachfüllen des Wassers in Wanne Remplissage et remise à niveau automatique de l'eau dans la cuve Llenado y relleno automático de agua en la cuba	<b>903,00</b>  ogni vasca each tank jeder Becken chaque cuve cada cuba

**BAGNOMARIA ELETTRICI**  
 ELECTRIC BAINS-MARIE- ELEKTRO WASSERBÄDER- BAINS-MARIE ÉLECTRIQUE -  
 BAÑOS MARÍA ELÉCTRICO

	Model	 (A x B x C) mm	kW	Cap.	€
	Modello su vano a giorno - Model on open cabinet - Modell mit offenem Unterbau - Modèle sur meuble ouvert - Modelo abierto				
	L7/KME1BA	400x700x850h	⚡ 1,5  230V~ 50/60Hz	GN 1/1	  1.974,00
	L7/KME2BA	800x700x850h	⚡ 3,0  230V~ 50/60Hz	GN 2/1	  2.614,00

Cestelli e coperchi non in dotazione - Baskets and lids are not included - Körbe und Deckeln im Preis nicht imbegriffen - Paniers et couvercles pas compris dans le prix -  
Cestas y la tapas no incluidas en el precio

**ACCESSORI- ACCESSORIES- ZUBEHÖRE- ACCESSOIRES- ACCESORIOS**





















	L7/CH040	mm.400	Anta - Door - Tür - Porte - Puerta	205,00
	56/89900006	530x325x150h	Vaschetta inox - S/s GN 1/1 cap. lt 21,3	84,00
	56/89900060	354x325x150h	Vaschetta inox - S/s GN 2/3 cap. lt 13,2	60,00
	56/89900030	265x325x150h	Vaschetta inox - S/s GN 1/2 cap. lt 9,7	50,00
	56/89900010	176x325x150h	Vaschetta inox - S/s GN 1/3 cap. lt 5,8	41,00
	56/89900040	162x265x150h	Vaschetta inox - S/s GN 1/4 cap. lt 4,1	32,00
	56/89900020	162x176x150h	Vaschetta inox - S/s GN 1/6 cap. lt 2,4	31,00
	56/89901002	530x325	Coperchio inox - S/s lid GN 1/1	28,00
	56/89901006	354x325	Coperchio inox - S/s lid GN 2/3	26,00
	56/89901001	265x325	Coperchio inox - S/s lid GN 1/2	21,00
	56/89901007	176x325	Coperchio inox - S/s lid GN 1/3	17,00
	56/89901003	162x265	Coperchio inox - S/s lid GN 1/4	14,00
	56/89901000	162x176	Coperchio inox - S/s lid GN 1/6	15,00
	23/99600003		Divisorio bacinelle - Dividing element for GN	30,00

**VAPORIERA DIM SUM ELETTRICA**

 ELECTRIC DIM SUM STEAMER - ELEKTRISCHER DIM SUM DAMPFGARER -  
 CUISEUR VAPEUR POUR DIM SUM ELECTRIQUE - VAPORRERA DIM SUM  
 ELÉCTRICA

	Model	 (A x B x C) mm	kW	Cap./Lt.	Baskets included	€
Modello su vano a giorno - Model on open cabinet - Modell mit offenem Unterbau - Modèle sur meuble ouvert - Modelo abierto						
	L7/DKE400BA	400x700x850h	⚡ 3,5  400V3N~ 50/60Hz	GN 1/1 Lt.24		4.011,00
	L7/DSE400BA	400x700x850h	⚡ 7,0  400V3N~ 50/60Hz	GN 1/1 Lt.24		4.123,00
	L7/DKE800BA	800x700x850h	⚡ 7,0  400V3N~ 50/60Hz	GN 2/1 Lt.55		5.423,00
	L7/DSE800BA	800x700x850h	⚡ 14,0  400V3N~ 50/60Hz	GN 2/1 Lt.55		5.579,00
Cestelli in bambù in dotazione - Equipped with bamboo containers - Inkl. Bambù Behälter - Bacs bambù compris dans le prix - Recipientes bambù en dotación						
<b>ACCESSORI- ACCESSORIES- ZUBEHÖRE- ACCESSOIRES- ACCESORIOS</b>						
	L7/CH040	mm.400	Anta - Door - Tür - Porte - Puerta			205,00
	21/99900369	Ø 150 mm	Set cestelli in bambù (3 cesti + 1 coperchio) Bambù set (3 baskets + 1 lid) Bambus Set (3 Körbe + 1 Deckel)			53,00
	21/99900379	Ø 180 mm	Set cestelli in bambù (3 cesti + 1 coperchio) Bambù set (3 baskets + 1 lid) Bambus Set (3 Körbe + 1 Deckel)			60,00
	21/99900389	Ø 210 mm	Set cestelli in bambù (3 cesti + 1 coperchio) Bambù set (3 baskets + 1 lid) Bambus Set (3 Körbe + 1 Deckel)			68,00

**IRIGLIE A PIETRA LAVICA**  
 AVASTONE GRILL - LAVASTEIN-GRILL - GRILLES PIERRE VOLCANIQUE -  
 PARRILLAS DE PIEDRA VOLCÁNICA







	Model	 (A x B x C) mm	kW	Grid	Kg. Lava rock	€
	L7/BS1BB	400x700x275h	8,0		5	2.500,00
	L7/BS2BB	800x700x275h	16,0		10	3.644,00
	L7/BS3BB	1200x700x275h	24,0		18	5.416,00
	L7/BS1BA	400x700x850h	8,0		5	2.688,00
	L7/BS2BA	800x700x850h	16,0		10	3.916,00
	L7/BS3BA	1200x700x850h	24,0		18	5.807,00
	L7/BS1BC	400x700x850h	8,0		5	2.890,00
	L7/BS2BC	800x700x850h	16,0		10	4.317,00
	L7/BS3BC2	1200x700x850h	24,0		18	6.358,00

ACCESSORI A PAG. 60 - ACCESSORIES SEE PG. 60

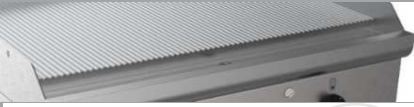
**FRY-TOP GAS**

GAS GRIDDLE PLATES - GAS GRILLPLATTEN - FRY-TOP GAZ - FRY-TOP A GAS

**LADY700**

	Model	F K C	 (A x B x C) mm	kW	UE	Extra UE	Dim.cooking plate mm.	€
	L7/KTG1BBL	F	400x700x275h	6,0	•	•	396x530	1.993,00
	L7/KTG1BBLK	K						2.307,00
	L7/KTG1BBLC	C						2.549,00
	L7/KTG1BBR	F	400x700x275h	6,0	•	•	396x530	2.045,00
	L7/KTG1BBRK	K						2.345,00
	L7/KTG1BBRC	C						2.617,00
	L7/FTG2BBL	F	700x700x275h	12,0	•	•	696x530	2.543,00
	L7/FTG2BBLK	K						3.211,00
	L7/FTG2BBLC	C						3.499,00
	L7/KTG2BBL	F	800x700x275h	12,0	•	•	796x530	2.696,00
	L7/KTG2BBLK	K						3.279,00
	L7/KTG2BBLC	C						3.632,00
	L7/FTG2BBR	F	700x700x275h	12,0	•	•	696x530	2.756,00
	L7/FTG2BBRK	K						3.381,00
	L7/FTG2BBRC	C						3.641,00
	L7/KTG2BBR	F	800x700x275h	12,0	•	•	796x530	2.909,00
	L7/KTG2BBRK	K						3.451,00
	L7/KTG2BBRC	C						3.774,00
	L7/FTG2BBM	F	700x700x275h	12,0	•	•	696x530	2.639,00
	L7/FTG2BBMK	K						3.293,00
	L7/FTG2BBMC	C						3.587,00
	L7/KTG2BBM	F	800x700x275h	12,0	•	•	796x530	2.794,00
	L7/KTG2BBMK	K						3.362,00
	L7/KTG2BBMC	C						3.753,00

**F** - Piastra in acciaio semi-dolce - Semi-mild steel plate - Halbweiche Stahlplatte - Plaque en acier demi-doux - Plancha de acero semi-suave

**K** - Piastra conforme a normativa CE 1935/2004-MOCA - Plate in compliance with EC 1935/2004 Regulation-FCM - LKM-Platte konform mit CE 1935/2004 - Plaque en ligne avec le règlement CE 1935/2004-MCDA - Plancha conforme al reglamento CE 1935/2004-MOCA

**C** - Piastra cromata - Chromium plate version - Ausführung mit verchromte Platte - Version chromée - Versión cromada

## FRY-TOP GAS

GAS GRIDDLE PLATES - GAS GRILLPLATTEN - FRY-TOP GAZ - FRY-TOP A GAS

LADY700

	Model	F K C	 (A x B x C) mm	kW	UE	Extra UE	Dim.cooking plate mm.	€
	L7/KTG1BAL	F	400x700x850h	6,0	•	•	396x530	2.345,00
	L7/KTG1BALK	K						2.530,00
	L7/KTG1BALC	C						2.899,00
	L7/KTG1BAR	F	400x700x850h	6,0	•	•	396x530	2.397,00
	L7/KTG1BARK	K						2.586,00
	L7/KTG1BARC	C						2.966,00
	L7/FTG2BAL	F	700x700x850h	12,0	•	•	696x530	2.839,00
	L7/FTG2BALK	K						3.503,00
	L7/FTG2BALC	C						3.797,00
	L7/KTG2BAL	F	800x700x850h	12,0	•	•	796x530	3.156,00
	L7/KTG2BALK	K						3.576,00
	L7/KTG2BALC	C						4.091,00
	L7/FTG2BAR	F	700x700x850h	12,0	•	•	696x530	3.051,00
	L7/FTG2BARK	K						3.670,00
	L7/FTG2BARC	C						3.938,00
	L7/KTG2BAR	F	800x700x850h	12,0	•	•	796x530	3.366,00
	L7/KTG2BARK	K						3.748,00
	L7/KTG2BARC	C						4.235,00
	L7/FTG2BAM	F	700x700x850h	12,0	•	•	696x530	2.937,00
	L7/FTG2BAMK	K						3.586,00
	L7/FTG2BAMC	C						3.884,00
	L7/KTG2BAM	F	800x700x850h	12,0	•	•	796x530	3.252,00
	L7/KTG2BAMK	K						3.659,00
	L7/KTG2BAMC	C						4.212,00

**F** - Piastra in acciaio semi-dolce - Semi-mild steel plate - Halbweiche Stahlplatte - Plaque en acier demi-doux - Plancha de acero semi-suave

**K** - Piastra conforme a normativa CE 1935/2004-MOCA - Plate in compliance with EC 1935/2004 Regulation-FCM - LKM-Platte konform mit CE 1935/2004 - Plaque en ligne avec le règlement CE 1935/2004-MCDA - Plancha conforme al reglamento CE 1935/2004-MOCA

**C** - Piastra cromata - Chromium plate version - Ausführung mit verchromte Platte - Version chromée - Versión cromada

**FRY-TOP ELETTRICO**

ELECTRIC GRIDDLE PLATES - ELEKTRO GRILLPLATTEN - FRY-TOP ÉLECTRIQUE - FRY-TOP ELÉCTRICOS

**LADY700**

	Model	F K C	 (A x B x C) mm	kW	UE	Extra UE	Dim.cooking plate mm.	€
	L7/KTE1BBL	F	400x700x275h	5,4 400V3N~ 50/60Hz	•	•	396x530	2.078,00
	L7/KTE1BBLK	K						2.392,00
	L7/KTE1BBLC	C						2.653,00
	L7/KTE1BBR	F	400x700x275h	5,4 400V3N~ 50/60Hz	•	•	4396x530	2.132,00
	L7/KTE1BBRK	K						2.432,00
	L7/KTE1BBRC	C						2.724,00
	L7/FTE2BBL	F	700x700x275h	10,8 400V3N~ 50/60Hz	•	•	696x530	2.657,00
	L7/FTE2BBLK	K						3.324,00
	L7/FTE2BBLC	C						3.614,00
	L7/KTE2BBL	F	800x700x275h	10,8 400V3N~ 50/60Hz	•	•	796x530	2.809,00
	L7/KTE2BBLK	K						3.392,00
	L7/KTE2BBLC	C						3.778,00
	L7/FTE2BBR	F	700x700x275h	10,8 400V3N~ 50/60Hz	•	•	696x530	2.878,00
	L7/FTE2BBRK	K						3.501,00
	L7/FTE2BBRC	C						3.763,00
	L7/KTE2BBR	F	800x700x275h	10,8 400V3N~ 50/60Hz	•	•	796x530	3.030,00
	L7/KTE2BBRK	K						3.574,00
	L7/KTE2BBRC	C						3.928,00
	L7/FTE2BBM	F	700x700x275h	10,8 400V3N~ 50/60Hz	•	•	696x530	2.758,00
	L7/FTE2BBMK	K						3.409,00
	L7/FTE2BBMC	C						3.746,00
	L7/KTE2BBM	F	800x700x275h	10,8 400V3N~ 50/60Hz	•	•	796x530	2.911,00
	L7/KTE2BBMK	K						3.480,00
	L7/KTE2BBMC	C						3.903,00

**F** - Piastra in acciaio semi-dolce - Semi-mild steel plate - Halbweiche Stahlplatte - Plaque en acier demi-doux - Plancha de acero semi-suave

**K** - Piastra conforme a normativa CE 1935/2004-MOCA - Plate in compliance with EC 1935/2004 Regulation-FCM - LKM-Platte konform mit CE 1935/2004 - Plaque en ligne avec le règlement CE 1935/2004-MCDA - Plancha conforme al reglamento CE 1935/2004-MOCA

**C** - Piastra cromata - Chromium plate version - Ausführung mit verchromte Platte - Version chromée - Versión cromada

## FRY-TOP ELETTRICO

ELECTRIC GRIDDLE PLATES - ELEKTRO GRILLPLATTEN - FRY-TOP ÉLECTRIQUE - FRY-TOP ELÉCTRICOS

LADY700

	Model	F K C	 (A x B x C) mm	kW	UE	Extra UE	Dim.cooking plate mm.	€
	L7/KTE1BAL	F	400x700x850h	5,4 400V3N~ 50/60Hz	•	•	396x530	2.430,00
	L7/KTE1BALK	K						2.616,00
	L7/KTE1BALC	C						3.004,00
	L7/KTE1BAR	F	400x700x850h	5,4 400V3N~ 50/60Hz	•	•	396x530	2.482,00
	L7/KTE1BARK	K						2.672,00
	L7/KTE1BARC	C						3.073,00
	L7/FTE2BAL	F	700x700x850h	10,8 400V3N~ 50/60Hz	•	•	696x530	2.955,00
	L7/FTE2BALK	K						3.614,00
	L7/FTE2BALC	C						3.911,00
	L7/KTE2BAL	F	800x700x850h	10,8 400V3N~ 50/60Hz	•	•	796x530	3.270,00
	L7/KTE2BALK	K						3.687,00
	L7/KTE2BALC	C						4.238,00
	L7/FTE2BAR	F	700x700x850h	10,8 400V3N~ 50/60Hz	•	•	696x530	3.173,00
	L7/FTE2BARK	K						3.792,00
	L7/FTE2BARC	C						4.101,00
	L7/KTE2BAR	F	800x700x850h	10,8 400V3N~ 50/60Hz	•	•	796x530	3.489,00
	L7/KTE2BARK	K						3.870,00
	L7/KTE2BARC	C						4.386,00
	L7/FTE2BAM	F	700x700x850h	10,8 400V3N~ 50/60Hz	•	•	696x530	3.053,00
	L7/FTE2BAMK	K						3.700,00
	L7/FTE2BAMC	C						4.042,00
	L7/KTE2BAM	F	800x700x850h	10,8 400V3N~ 50/60Hz	•	•	796x530	3.370,00
	L7/KTE2BAMK	K						3.775,00
	L7/KTE2BAMC	C						4.363,00

F - Piastra in acciaio semi-dolce - Semi-mild steel plate - Halbweiche Stahlplatte - Plaque en acier demi-doux - Plancha de acero semi-suave

K - Piastra conforme a normativa CE 1935/2004-MOCA - Plate in compliance with EC 1935/2004 Regulation-FCM - LKM-Platte konform mit CE 1935/2004 - Plaque en ligne avec le règlement CE 1935/2004-MCDA - Plancha conforme al reglamento CE 1935/2004-MOCA

C - Piastra cromata - Chromium plate version - Ausführung mit verchromte Platte - Version chromée - Versión cromada

**ELEMENTI NEUTRI**  
 NEUTRAL UNITS- ARBEITSELEMENTE - ELEMENTS NEUTRES - MUEBLES  
 NEUTROS

	Model	 (A x B x C) mm		€
	L7/ENN1BB	350x700x275h		<b>674,00</b>
	L7/ENN1CB	350x700x275h	con 1 cassetto - with 1 drawer - mit 1 Schublade - avec 1 tiroir - con 1 cajón	<b>1.144,00</b>
	L7/KNN1BB	400x700x275h		<b>710,00</b>
	L7/KNN1CB	400x700x275h	con 1 cassetto GN 1/1 - with 1 drawer GN 1/1- mit 1 Schublade GN 1/1 - avec 1 tiroir GN 1/1 - con 1 cajón GN 1/1	<b>1.182,00</b>
	L7/ENN2BB	700x700x275h		<b>935,00</b>
	L7/ENN2CB	700x700x275h	con 1 cassetto - with 1 drawer - mit 1 Schublade - avec 1 tiroir - con 1 cajón	<b>1.450,00</b>
	L7/KNN2BB	800x700x275h		<b>981,00</b>
	L7/KNN2CB	800x700x275h	con 1 cassetto GN 2/1 - with 1 drawer GN 2/1- mit 1 Schublade GN 2/1 - avec 1 tiroir GN 2/1 - con 1 cajón GN 2/1	<b>1.496,00</b>
	L7/ENN1BA	350x700x850h		<b>948,00</b>
	L7/ENN1CA	350x700x850h	con 1 cassetto - with 1 drawer - mit 1 Schublade - avec 1 tiroir - con 1 cajón	<b>1.414,00</b>
	L7/KNN1BA	400x700x850h		<b>985,00</b>
	L7/KNN1CA	400x700x850h	con 1 cassetto GN 1/1 - with 1 drawer GN 1/1- mit 1 Schublade GN 1/1 - avec 1 tiroir GN 1/1 - con 1 cajón GN 1/1	<b>1.456,00</b>
	L7/ENN2BA	700x700x850h		<b>1.258,00</b>
	L7/ENN2CA	700x700x850h	con 1 cassetto - with 1 drawer - mit 1 Schublade - avec 1 tiroir - con 1 cajón	<b>1.773,00</b>
	L7/KNN2BA	800x700x850h		<b>1.304,00</b>
	L7/KNN2CA	800x700x850h	con 1 cassetto GN 2/1 - with 1 drawer GN 2/1- mit 1 Schublade GN 2/1 - avec 1 tiroir GN 2/1 - con 1 cajón GN 2/1	<b>1.819,00</b>

LADY700







**ACCESSORI- ACCESSORIES- ZUBEHÖRE- ACCESSOIRES- ACCESORIOS**

	L7/CH035	mm.350	Anta - Door - Tür - Porte - Puerta	<b>196,00</b>
	L7/CH040	mm.400	Anta - Door - Tür - Porte - Puerta	<b>205,00</b>

## PENTOLE GAS





GAS BOILING PANS - GAS KOCHKESSEL - MARMITES À GAZ - MARMITAS A GAS

LADY700

	Model	 (A x B x C) mm	kW	Lt.	Tank dim.	€
Riscaldamento diretto - Direct heating - Direkte Beheizung - Chauffage direct - Calentamiento directo						
	L7/PDG501	800x700x850h	 15,5	55/60	∅ 400x475 mm	6.343,00
Riscaldamento indiretto - Indirect heating - Indirekte Beheizung - Chauffage indirect - Calentamiento indirecto						
	L7/PIG501	800x700x850h	 15,5	55/60	∅ 400x475 mm	8.245,00

## PENTOLE ELETTRICHE

ELECTRIC BOILING PANS - ELEKTRO KOCHKESSEL - MARMITES ÉLECTRIQUES - MARMITAS ÉLECTRICAS





	Model	 (A x B x C) mm	kW	Lt.	Tank dim.	€
Riscaldamento indiretto - Indirect heating - Indirekte Beheizung - Chauffage indirect - Calentamiento indirecto						
	L7/PIE501	800x700x850h	 9,0  400V3N~ 50/60Hz	55/60	∅ 400x475 mm	7.723,00

Cestelli non in dotazione - Baskets are not included - Körbe im Preis nicht imbegriffen - Paniers pas compris dans le prix - Cestas no incluidas en el precio

## ACCESSORI- ACCESSORIES- ZUBEHÖRE- ACCESSOIRES- ACCESORIOS

	CES10500	∅ 360x405h Lt. 50	Cestello per pentole ad 1 settore Basket for boiling pans 1 sector Körbe für Kochkesseln 1 Sektor Panier pour marmites 1 secteur Cesta para marmitas 1 sector			818,00
---	----------	----------------------	---	--	--	--------



**BRASIERE GAS**  
 GAS TILTING BRATT PANS - GAS KIPPBRATPFANNEN - SAUTEUSES  
 BASCULANTES À GAZ - SARTENES BASCULANTES A GAS

	Model	 (A x B x C) mm	kW	Lt.	Bottom type	€
Sollevamento manuale - Manual tilt - Manuelle Kippung - Renversement manuel - Elevación manual						
	<b>L7/BRG150M</b>	800x700x850h	12,0	40/52	AISI 304 mm.10	<b>6.870,00</b>
Sollevamento motorizzato - Electric tilt - Motorgetriebene Kippung - Renversement motorisé - Elevación motorizada						
	<b>L7/BRG150A</b>	800x700x850h	12,0	40/52	AISI 304 mm.10	<b>9.591,00</b>





**BRASIERE ELETTRICHE**

ELECTRIC TILTING BRATT PANS - ELEKTRO KIPPBRATPFANNEN - SAUTEUSES  
 BASCULANTES ÉLECTRIQUES - SARTENES BASCULANTES ELÉCTRICAS

Sollevamento manuale - Manual tilt - Manuelle Kippung - Renversement manuel - Elevación manual

	<b>L7/BRE150M</b>	800x700x850h	8,7	40/52	AISI 304 mm.10	<b>6.878,00</b>
Sollevamento motorizzato - Electric tilt - Motorgetriebene Kippung - Renversement motorisé - Elevación motorizada						
	<b>L7/BRE150A</b>	800x700x850h	8,7	40/52	AISI 304 mm.10	<b>8.369,00</b>

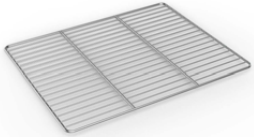
LADY700

	Model	 (A x B x C) mm	Description	€
<b>ACCESSORI- ACCESSORIES- ZUBEHÖRE- ACCESSOIRES- ACCESORIOS</b>				
	L7/EX035	350x50x170h	Prolunga camino - Flue extentions	<b>156,00</b>
	L7/EX040	400x50x170h	Prolunga camino - Flue extentions	<b>166,00</b>
	L7/EX070	700x50x170h	Prolunga camino - Flue extentions	<b>227,00</b>
	L7/EX080	800x50x170h	Prolunga camino - Flue extentions	<b>245,00</b>
	L7/EX105	1.050x50x170h	Prolunga camino - Flue extentions	<b>299,00</b>
	L7/EX120	1.200x50x170h	Prolunga camino - Flue extentions	<b>324,00</b>
	15/99901029		Riduzione per griglia - Reduction grid for grid - Reduzierrost für Rost - Grille de reduction pour support poele - Rejilla reductore para parrilla	<b>50,00</b>
	21/99600079	535x450	Griglia cromata interna forno - Chromed grid for oven <b>Mod. FO/FE</b>	<b>66,00</b>
	21/GX2/1	530x650	Griglia cromata interna forno - Chromed grid for oven <b>Mod. LO/LE</b>	<b>75,00</b>
	21/99600089	885x450	Griglia cromata interna forno - Chromed grid for oven <b>Mod. FM</b>	<b>110,00</b>
	SET4RUOTE 2 X 63/99000143 2 X 63/99000144	∅ mm.100	Set nr.4 ruote ∅ mm.100 (nr.2 con freno) Set of nr.4 castors ∅ mm.100 (nr.2 with breaks) Set von nr.4 Räder ∅ mm.100 (nr.2 mit Bremse) Set de 4 roues ∅ mm.100 (nr.2 avec freins) Set de 4 ruedas ∅ mm.100 (nr.1 con frenos)	<b>400,00</b>
	COP.PIE	H. mm.110	Zoccolo copertura piedi Cover for feet in stainless steel Fußbende für Füße aus Edelstahl Couverture pour les pieds en acier inox Sueco para patas en acero inoxidable	<b>292,00</b>
<small>AL METRO LINEARE - FOR LINEAR METER - FÜR LINEARMETER - AU METRE LINÉAIRE - POR METRO LINEAR</small>				

<b>ACCESSORI - ACCESSORIES- ZUBEHÖRE- ACCESSOIRES- ACCESORIOS</b>				
	15/99901889		Pietra lavica - Lava rock - Lavastein - Lave volcanique - Lava Volcànica	<b>12,00 / Kg</b>
	21/99600004	375x461	Griglia a canaletto per carne - Steel "V" shape cooking grid for meat	<b>192,00</b>
	21/99600003	775x461	Griglia a canaletto per carne	<b>310,00</b>
	21/99600002	375x461	Griglia in tondino ∅ mm.8 per pesce - Steel round cooking grid ∅ mm.8 for fish	<b>302,00</b>
	21/99600001	775x461	Griglia in tondino ∅ mm.8 per pesce - Steel round cooking grid ∅ mm.8 for fish	<b>464,00</b>

# Lady



## Lady Q serie 900



**CUCINE GAS**  
 GAS RANGES - GASHERDE - CUISINIÈRES GAZ - COCINAS GAS

	Model	 (A x B x C) mm	kW	Burners	Oven	€
Versione da banco - Bench model - Auf Tischmodell - Modèle à poser - Modelo de sobremesa						
	<b>LQ/CUG2BB.1P1M</b>	400x900x275h	9,0			<b>1.770,00</b>
	<b>LQ/CUG2BB.1M1G</b>	400x900x275h	12,9			<b>1.854,00</b>
	<b>LQ/CUG2BB.2G</b>	400x900x275h	14,8			<b>1.939,00</b>
A scelta tra - Choice among - Wahl zwischen Elegibles entre - Choisir entre kW 3,5 - kW 5,5 - kW 7,4 - kW 9,0	<b>LQ/CUG2BB....</b>	400x900x275h	A richiesta Upon request			.....
	<b>LQ/CUG4BB.2P1M1G</b>	800x900x275h	19,9			<b>2.852,00</b>
	<b>LQ/CUG4BB.1P1M2G</b>	800x900x275h	23,8			<b>2.936,00</b>
	<b>LQ/CUG4BB.4G</b>	800x900x275h	29,6			<b>3.106,00</b>
A scelta tra - Choice among - Wahl zwischen Elegibles entre - Choisir entre kW 3,5 - kW 5,5 - kW 7,4 - kW 9,0	<b>LQ/CUG4BB....</b>	800x900x275h	A richiesta Upon request			.....
	<b>LQ/CUG6BB.3P1M2G</b>	1.200x900x275h	30,8			<b>3.914,00</b>
	<b>LQ/CUG6BB.1P2M3G</b>	1.200x900x275h	36,7			<b>3.999,00</b>
	<b>LQ/CUG6BB.6G</b>	1.200x900x275h	44,4			<b>4.253,00</b>
A scelta tra - Choice among - Wahl zwischen Elegibles entre - Choisir entre kW 3,5 - kW 5,5 - kW 7,4 - kW 9,0	<b>LQ/CUG6BB....</b>	1.200x900x275h	A richiesta Upon request			.....
	<b>LQ/CUG8BB.3P3M2G</b>	1.600x900x275h	41,8			<b>5.229,00</b>
	<b>LQ/CUG8BB.2P2M4G</b>	1.600x900x275h	47,6			<b>5.399,00</b>
	<b>LQ/CUG8BB.8G</b>	1.600x900x275h	59,2			<b>5.715,00</b>
A scelta tra - Choice among - Wahl zwischen Elegibles entre - Choisir entre kW 3,5 - kW 5,5 - kW 7,4 - kW 9,0	<b>LQ/CUG8BB....</b>	1.600x900x275h	A richiesta Upon request			.....

**LADYQ900**

**CUCINE GAS**  
 GAS RANGES - GASHERDE - CUISINIÈRES GAZ - COCINAS GAS



















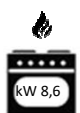

	Model	 A B C (A x B x C) mm	kW	Burners	Oven	€								
	Modello su vano a giorno - Model on open cabinet - Modell mit offenem Unterbau - Modèle sur meuble ouvert - Modelo abierto													
	LQ/CUG2BA.1P1M	400x900x850h	🔥 9,0	<table border="1"><tr><td>3,5</td></tr><tr><td>5,5</td></tr></table>	3,5	5,5		<b>2.200,00</b>						
	3,5													
	5,5													
LQ/CUG2BA.1M1G	400x900x850h	🔥 12,9	<table border="1"><tr><td>5,5</td></tr><tr><td>7,4</td></tr></table>	5,5	7,4		<b>2.286,00</b>							
5,5														
7,4														
LQ/CUG2BA.2G	400x900x850h	🔥 14,8	<table border="1"><tr><td>7,4</td></tr><tr><td>7,4</td></tr></table>	7,4	7,4		<b>2.370,00</b>							
7,4														
7,4														
A scelta tra - Choice among - Wahl zwischen Elegibles entre - Choisir entre kW 3,5 - kW 5,5 - kW 7,4 - kW 9,0	LQ/CUG2BA....	400x900x850h	A richiesta Upon request	<table border="1"><tr><td>?</td></tr><tr><td>?</td></tr></table>	?	?		.....						
?														
?														
	LQ/CUG4BA.2P1M1G	800x900x850h	🔥 19,9	<table border="1"><tr><td>3,5</td><td>7,4</td></tr><tr><td>5,5</td><td>3,5</td></tr></table>	3,5	7,4	5,5	3,5		<b>3.298,00</b>				
	3,5	7,4												
	5,5	3,5												
LQ/CUG4BA.1P1M2G	800x900x850h	🔥 23,8	<table border="1"><tr><td>3,5</td><td>5,5</td></tr><tr><td>7,4</td><td>7,4</td></tr></table>	3,5	5,5	7,4	7,4		<b>3.383,00</b>					
3,5	5,5													
7,4	7,4													
LQ/CUG4BA.4G	800x900x850h	🔥 29,6	<table border="1"><tr><td>7,4</td><td>7,4</td></tr><tr><td>7,4</td><td>7,4</td></tr></table>	7,4	7,4	7,4	7,4		<b>3.552,00</b>					
7,4	7,4													
7,4	7,4													
A scelta tra - Choice among - Wahl zwischen Elegibles entre - Choisir entre kW 3,5 - kW 5,5 - kW 7,4 - kW 9,0	LQ/CUG4BA....	800x900x850h	A richiesta Upon request	<table border="1"><tr><td>?</td><td>?</td></tr><tr><td>?</td><td>?</td></tr></table>	?	?	?	?		.....				
?	?													
?	?													
	LQ/CUG6BA.3P1M2G	1.200x900x850h	🔥 30,8	<table border="1"><tr><td>7,4</td><td>3,5</td><td>7,4</td></tr><tr><td>3,5</td><td>5,5</td><td>3,5</td></tr></table>	7,4	3,5	7,4	3,5	5,5	3,5		<b>4.574,00</b>		
	7,4	3,5	7,4											
	3,5	5,5	3,5											
LQ/CUG6BA.1P2M3G	1.200x900x850h	🔥 36,7	<table border="1"><tr><td>5,5</td><td>7,4</td><td>3,5</td></tr><tr><td>7,4</td><td>5,5</td><td>7,4</td></tr></table>	5,5	7,4	3,5	7,4	5,5	7,4		<b>4.659,00</b>			
5,5	7,4	3,5												
7,4	5,5	7,4												
LQ/CUG6BA.6G	1.200x900x850h	🔥 44,4	<table border="1"><tr><td>7,4</td><td>7,4</td><td>7,4</td></tr><tr><td>7,4</td><td>7,4</td><td>7,4</td></tr></table>	7,4	7,4	7,4	7,4	7,4	7,4		<b>4.912,00</b>			
7,4	7,4	7,4												
7,4	7,4	7,4												
A scelta tra - Choice among - Wahl zwischen Elegibles entre - Choisir entre kW 3,5 - kW 5,5 - kW 7,4 - kW 9,0	LQ/CUG6BA....	1.200x900x850h	A richiesta Upon request	<table border="1"><tr><td>?</td><td>?</td><td>?</td></tr><tr><td>?</td><td>?</td><td>?</td></tr></table>	?	?	?	?	?	?		.....		
?	?	?												
?	?	?												
	LQ/CUG8BA.3P3M2G	1.600x900x850h	🔥 41,8	<table border="1"><tr><td>7,4</td><td>3,5</td><td>7,4</td><td>5,5</td></tr><tr><td>3,5</td><td>5,5</td><td>3,5</td><td>5,5</td></tr></table>	7,4	3,5	7,4	5,5	3,5	5,5	3,5	5,5		<b>6.304,00</b>
	7,4	3,5	7,4	5,5										
	3,5	5,5	3,5	5,5										
LQ/CUG8BA.2P2M4G	1.600x900x850h	🔥 47,6	<table border="1"><tr><td>3,5</td><td>3,5</td><td>5,5</td><td>5,5</td></tr><tr><td>7,4</td><td>7,4</td><td>7,4</td><td>7,4</td></tr></table>	3,5	3,5	5,5	5,5	7,4	7,4	7,4	7,4		<b>6.474,00</b>	
3,5	3,5	5,5	5,5											
7,4	7,4	7,4	7,4											
LQ/CUG8BA.8G	1.600x900x850h	🔥 59,2	<table border="1"><tr><td>7,4</td><td>7,4</td><td>7,4</td><td>7,4</td></tr><tr><td>7,4</td><td>7,4</td><td>7,4</td><td>7,4</td></tr></table>	7,4	7,4	7,4	7,4	7,4	7,4	7,4	7,4		<b>6.812,00</b>	
7,4	7,4	7,4	7,4											
7,4	7,4	7,4	7,4											
A scelta tra - Choice among - Wahl zwischen Elegibles entre - Choisir entre kW 3,5 - kW 5,5 - kW 7,4 - kW 9,0	LQ/CUG8BA....	1.600x900x850h	A richiesta Upon request	<table border="1"><tr><td>?</td><td>?</td><td>?</td><td>?</td></tr><tr><td>?</td><td>?</td><td>?</td><td>?</td></tr></table>	?	?	?	?	?	?	?	?		.....
?	?	?	?											
?	?	?	?											

**CUCINE GAS**  
 GAS RANGES - GASHERDE - CUISINIÈRES GAZ - COCINAS GAS

	Model	 (A x B x C) mm	kW	Burners	Oven	€						
Modello con forno - Model with oven - Modell mit Backofen - Modèle avec four - Modelo con horno												
	LQ/CUG4NG.2P1M1G	800x900x850h	 28,5	<table border="1" data-bbox="1169 488 1241 555"> <tr><td>3,5</td><td>7,4</td></tr> <tr><td>5,5</td><td>8,5</td></tr> </table>	3,5	7,4	5,5	8,5		4.602,00		
3,5	7,4											
5,5	8,5											
	LQ/CUG4NG.1P1M2G	800x900x850h	 32,4	<table border="1" data-bbox="1169 577 1241 645"> <tr><td>3,5</td><td>5,5</td></tr> <tr><td>7,4</td><td>7,4</td></tr> </table>	3,5	5,5	7,4	7,4		4.687,00		
3,5	5,5											
7,4	7,4											
	LQ/CUG4NG.4G	800x900x850h	 38,2	<table border="1" data-bbox="1169 678 1241 745"> <tr><td>7,4</td><td>7,4</td></tr> <tr><td>7,4</td><td>7,4</td></tr> </table>	7,4	7,4	7,4	7,4		4.867,00		
7,4	7,4											
7,4	7,4											
A scelta tra - Choice among - Wahl zwischen Elegibles entre - Choisir entre kW 3,5 - kW 5,5 - kW 7,4 - kW 9,0	LQ/CUG4NG....	800x900x850h	A richiesta Upon request	<table border="1" data-bbox="1169 768 1241 835"> <tr><td>?</td><td>?</td></tr> <tr><td>?</td><td>?</td></tr> </table>	?	?	?	?	GN 2/1 mm.540x745x310h	.....		
?	?											
?	?											
	LQ/CUG4NE.2P1M1G	800x900x850h	 19,9	<table border="1" data-bbox="1169 857 1241 925"> <tr><td>3,5</td><td>7,4</td></tr> <tr><td>5,5</td><td>8,5</td></tr> </table>	3,5	7,4	5,5	8,5		5.138,00		
3,5	7,4											
5,5	8,5											
	LQ/CUG4NE.1P1M2G	800x900x850h	 23,8	<table border="1" data-bbox="1169 947 1241 1014"> <tr><td>3,5</td><td>5,5</td></tr> <tr><td>7,4</td><td>7,4</td></tr> </table>	3,5	5,5	7,4	7,4		5.223,00		
3,5	5,5											
7,4	7,4											
	LQ/CUG4NE.4G	800x900x850h	 29,6	<table border="1" data-bbox="1169 1048 1241 1115"> <tr><td>7,4</td><td>7,4</td></tr> <tr><td>7,4</td><td>7,4</td></tr> </table>	7,4	7,4	7,4	7,4	400V3N~ 50/60Hz	5.405,00		
7,4	7,4											
7,4	7,4											
A scelta tra - Choice among - Wahl zwischen Elegibles entre - Choisir entre kW 3,5 - kW 5,5 - kW 7,4 - kW 9,0	LQ/CUG4NE....	800x900x850h	A richiesta Upon request	<table border="1" data-bbox="1169 1137 1241 1205"> <tr><td>?</td><td>?</td></tr> <tr><td>?</td><td>?</td></tr> </table>	?	?	?	?	GN 2/1 mm.540x745x310h	.....		
?	?											
?	?											
	LQ/CUG6NG.3P1M2G	1.200x900x850h	 39,4	<table border="1" data-bbox="1169 1227 1241 1294"> <tr><td>7,4</td><td>3,5</td><td>7,4</td></tr> <tr><td>3,5</td><td>5,5</td><td>3,5</td></tr> </table>	7,4	3,5	7,4	3,5	5,5	3,5		6.457,00
7,4	3,5	7,4										
3,5	5,5	3,5										
	LQ/CUG6NG.1P2M3G	1.200x900x850h	 45,3	<table border="1" data-bbox="1169 1317 1241 1384"> <tr><td>5,5</td><td>7,4</td><td>3,5</td></tr> <tr><td>7,4</td><td>5,5</td><td>7,4</td></tr> </table>	5,5	7,4	3,5	7,4	5,5	7,4		6.542,00
5,5	7,4	3,5										
7,4	5,5	7,4										
	LQ/CUG6NG.6G	1.200x900x850h	 53,0	<table border="1" data-bbox="1169 1417 1241 1485"> <tr><td>7,4</td><td>7,4</td><td>7,4</td></tr> <tr><td>7,4</td><td>7,4</td><td>7,4</td></tr> </table>	7,4	7,4	7,4	7,4	7,4	7,4		6.723,00
7,4	7,4	7,4										
7,4	7,4	7,4										
A scelta tra - Choice among - Wahl zwischen Elegibles entre - Choisir entre kW 3,5 - kW 5,5 - kW 7,4 - kW 9,0	LQ/CUG6NG....	1.200x900x850h	A richiesta Upon request	<table border="1" data-bbox="1169 1507 1241 1574"> <tr><td>?</td><td>?</td><td>?</td></tr> <tr><td>?</td><td>?</td><td>?</td></tr> </table>	?	?	?	?	?	?	GN 2/1 mm.540x745x310h	.....
?	?	?										
?	?	?										
	LQ/CUG6NE.3P1M2G	1.200x900x850h	 30,8	<table border="1" data-bbox="1169 1597 1241 1664"> <tr><td>7,4</td><td>3,5</td><td>7,4</td></tr> <tr><td>3,5</td><td>5,5</td><td>3,5</td></tr> </table>	7,4	3,5	7,4	3,5	5,5	3,5		6.893,00
7,4	3,5	7,4										
3,5	5,5	3,5										
	LQ/CUG6NE.1P2M3G	1.200x900x850h	 36,7	<table border="1" data-bbox="1169 1686 1241 1753"> <tr><td>5,5</td><td>7,4</td><td>3,5</td></tr> <tr><td>7,4</td><td>5,5</td><td>7,4</td></tr> </table>	5,5	7,4	3,5	7,4	5,5	7,4		6.982,00
5,5	7,4	3,5										
7,4	5,5	7,4										
	LQ/CUG6NE.6G	1.200x900x850h	 44,4	<table border="1" data-bbox="1169 1787 1241 1854"> <tr><td>7,4</td><td>7,4</td><td>7,4</td></tr> <tr><td>7,4</td><td>7,4</td><td>7,4</td></tr> </table>	7,4	7,4	7,4	7,4	7,4	7,4	400V3N~ 50/60Hz	7.167,00
7,4	7,4	7,4										
7,4	7,4	7,4										
A scelta tra - Choice among - Wahl zwischen Elegibles entre - Choisir entre kW 3,5 - kW 5,5 - kW 7,4 - kW 9,0	LQ/CUG6NE....	1.200x900x850h	A richiesta Upon request	<table border="1" data-bbox="1169 1877 1241 1944"> <tr><td>?</td><td>?</td><td>?</td></tr> <tr><td>?</td><td>?</td><td>?</td></tr> </table>	?	?	?	?	?	?	GN 2/1 mm.540x745x310h	.....
?	?	?										
?	?	?										

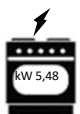
LADYQ900

**CUCINE GAS**  
 GAS RANGES - GASHERDE - CUISINIÈRES GAZ - COCINAS GAS

	Model	 (A x B x C) mm	kW	Burners	Oven	€
	LQ/CUG6FM.3P1M2G	1.200x900x850h	42,8		 kW 12	6.852,00
	LQ/CUG6FM.1P2M3G	1.200x900x850h	48,7			6.935,00
	LQ/CUG6FM.6G	1.200x900x850h	56,4			7.117,00
A scelta tra - Choice among - Wahl zwischen Elegibles entre - Choisir entre kW 3,5 - kW 5,5 - kW 7,4 - kW 9,0	LQ/CUG6FM....	1.200x900x850h	A richiesta Upon request		MAXI mm.935x550x310h	.....
	LQ/CUG8NG.3P3M2G	1.600x900x850h	59,0		2 X  kW 8,6	9.519,00
	LQ/CUG8NG.2P2M4G	1.600x900x850h	64,8			9.692,00
	LQ/CUG8NG.8G	1.600x900x850h	76,4			10.053,00
A scelta tra - Choice among - Wahl zwischen Elegibles entre - Choisir entre kW 3,5 - kW 5,5 - kW 7,4 - kW 9,0	LQ/CUG8NG....	1.600x900x850h	A richiesta Upon request		GN 2/1 mm.540x745x310h	.....
	LQ/CUG8NE.3P3M2G	1.600x900x850h	41,8		2 X  kW 5,48 400V3N~ 50/60Hz	10.128,00
	LQ/CUG8NE.2P2M4G	1.600x900x850h	47,6			10.299,00
	LQ/CUG8NE.8G	1.600x900x850h	59,2			10.662,00
A scelta tra - Choice among - Wahl zwischen Elegibles entre - Choisir entre kW 3,5 - kW 5,5 - kW 7,4 - kW 9,0	LQ/CUG8NE....	1.600x900x850h	A richiesta Upon request		GN 2/1 mm.540x745x310h	.....

LADYQ900

 Accessori in dotazione nr.1 griglia interna forno e nr. 1 riduzione fuoco - Accessories included nr.1 internal grid for oven and nr.1 reduction for burner - Zubehöre  
 inbegriffen nr.1 Rost für Ofen und nr.1 Reduzierrost für Brenner - Accessoires inclus nr.1 grille pour four et nr.1 grille de réduction pour brûleur - Accesorios incluidos  
 nr.1 parilla para horno y nr.1 rejilla reductora para quemador

**CUCINE GAS**  
 GAS RANGES - GASHERDE - CUISINIÈRES GAZ - COCINAS GAS

	Model	 (A x B x C) mm	kW	Burners	Oven	€
Versione da banco - Bench model - Auf Tischmodell - Modèle à poser - Modelo de sobremesa						
	<b>LQ/KUG2BB.1P1M</b>	450x900x275h	9,0			<b>1.813,00</b>
	<b>LQ/KUG2BB.1M1G</b>	450x900x275h	12,9			<b>1.898,00</b>
	<b>LQ/KUG2BB.2G</b>	450x900x275h	14,8			<b>1.990,00</b>
A scelta tra - Choice among - Wahl zwischen Elegibles entre - Choisir entre <b>kW 3,5 - kW 5,5 - kW 7,4 - kW 9,0</b>	<b>LQ/KUG2BB....</b>	450x900x275h	A richiesta Upon request			.....
	<b>LQ/KUG4BB.2P1M1G</b>	900x900x275h	19,9			<b>2.955,00</b>
	<b>LQ/KUG4BB.1P1M2G</b>	900x900x275h	23,8			<b>3.039,00</b>
	<b>LQ/KUG4BB.4G</b>	900x900x275h	29,6			<b>3.134,00</b>
A scelta tra - Choice among - Wahl zwischen Elegibles entre - Choisir entre <b>kW 3,5 - kW 5,5 - kW 7,4 - kW 9,0</b>	<b>LQ/KUG4BB....</b>	900x900x275h	A richiesta Upon request			.....
	<b>LQ/KUG6BB.3P1M2G</b>	1.350x900x275h	30,8			<b>4.059,00</b>
	<b>LQ/KUG6BB.1P2M3G</b>	1.350x900x275h	36,7			<b>4.143,00</b>
	<b>LQ/KUG6BB.6G</b>	1.350x900x275h	44,4			<b>4.325,00</b>
A scelta tra - Choice among - Wahl zwischen Elegibles entre - Choisir entre <b>kW 3,5 - kW 5,5 - kW 7,4 - kW 9,0</b>	<b>LQ/KUG6BB....</b>	1.350x900x275h	A richiesta Upon request			.....
	<b>LQ/KUG8BB.3P3M2G</b>	1.800x900x275h	41,8			<b>5.514,00</b>
	<b>LQ/KUG8BB.2P2M4G</b>	1.800x900x275h	47,6			<b>5.587,00</b>
	<b>LQ/KUG8BB.8G</b>	1.800x900x275h	59,2			<b>5.950,00</b>
A scelta tra - Choice among - Wahl zwischen Elegibles entre - Choisir entre <b>kW 3,5 - kW 5,5 - kW 7,4 - kW 9,0</b>	<b>LQ/KUG8BB....</b>	1.800x900x275h	A richiesta Upon request			.....

LADYQ900

**CUCINE GAS**  
 GAS RANGES - GASHERDE - CUISINIÈRES GAZ - COCINAS GAS

	Model	 A B C (A x B x C) mm	kW	Burners	Oven	€
	Modello su vano a giorno - Model on open cabinet - Modell mit offenem Unterbau - Modèle sur meuble ouvert - Modelo abierto					
	LQ/KUG2BA.1P1M	450x900x850h	9,0			2.256,00
	LQ/KUG2BA.1M1G	450x900x850h	12,9			2.341,00
	LQ/KUG2BA.2G	450x900x850h	14,8			2.433,00
A scelta tra - Choice among - Wahl zwischen Elegibles entre - Choisir entre kW 3,5 - kW 5,5 - kW 7,4 - kW 9,0	LQ/KUG2BA....	450x900x850h	A richiesta Upon request			.....
	LQ/KUG4BA.2P1M1G	900x900x850h	19,9			3.417,00
	LQ/KUG4BA.1P1M2G	900x900x850h	23,8			3.502,00
	LQ/KUG4BA.4G	900x900x850h	29,6			3.596,00
A scelta tra - Choice among - Wahl zwischen Elegibles entre - Choisir entre kW 3,5 - kW 5,5 - kW 7,4 - kW 9,0	LQ/KUG4BA....	900x900x850h	A richiesta Upon request			.....
	LQ/KUG6BA.3P1M2G	1.350x900x850h	30,8			4.739,00
	LQ/KUG6BA.1P2M3G	1.350x900x850h	36,7			4.823,00
	LQ/KUG6BA.6G	1.350x900x850h	44,4			4.917,00
A scelta tra - Choice among - Wahl zwischen Elegibles entre - Choisir entre kW 3,5 - kW 5,5 - kW 7,4 - kW 9,0	LQ/KUG6BA....	1.350x900x850h	A richiesta Upon request			.....
	LQ/KUG8BA.3P3M2G	1.800x900x850h	41,8			6.528,00
	LQ/KUG8BA.2P2M4G	1.800x900x850h	47,6			6.700,00
	LQ/KUG8BA.8G	1.800x900x850h	59,2			7.064,00
A scelta tra - Choice among - Wahl zwischen Elegibles entre - Choisir entre kW 3,5 - kW 5,5 - kW 7,4 - kW 9,0	LQ/KUG8BA....	1.800x900x850h	A richiesta Upon request			.....













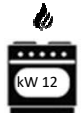

LADYQ900

**CUCINE GAS**  
 GAS RANGES - GASHERDE - CUISINIÈRES GAZ - COCINAS GAS

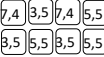
	Model	 (A x B x C) mm	kW	Burners	Oven	€
Modello con forno - Model with oven - Modell mit Backofen - Modèle avec four - Modelo con horno						
	LQ/KUG4NG.2P1M1G	900x900x850h	28,5			4.843,00
	LQ/KUG4NG.1P1M2G	900x900x850h	32,4			4.929,00
	LQ/KUG4NG.4G	900x900x850h	38,2			5.110,00
A scelta tra - Choice among - Wahl zwischen Elegibles entre - Choisir entre kW 3,5 - kW 5,5 - kW 7,4 - kW 9,0	LQ/KUG4NG....	900x900x850h	A richiesta Upon request		GN 2/1 mm.540x745x310h	.....
	LQ/KUG4NE.2P1M1G	900x900x850h	19,9			5.412,00
	LQ/KUG4NE.1P1M2G	900x900x850h	23,8			5.496,00
	LQ/KUG4NE.4G	900x900x850h	29,6		400V3N~ 50/60Hz	5.678,00
A scelta tra - Choice among - Wahl zwischen Elegibles entre - Choisir entre kW 3,5 - kW 5,5 - kW 7,4 - kW 9,0	LQ/KUG4NE....	900x900x850h	A richiesta Upon request		GN 2/1 mm.540x745x310h	.....
	LQ/KUG6NG.3P1M2G	1.350x900x850h	39,4			6.797,00
	LQ/KUG6NG.1P2M3G	1.350x900x850h	45,3			6.881,00
	LQ/KUG6NG.6G	1.350x900x850h	53,0			6.977,00
A scelta tra - Choice among - Wahl zwischen Elegibles entre - Choisir entre kW 3,5 - kW 5,5 - kW 7,4 - kW 9,0	LQ/KUG6LN....	1.350x900x850h	A richiesta Upon request		GN 2/1 mm.540x745x310h	.....
	LQ/KUG6NE.3P1M2G	1.350x900x850h	30,8			7.042,00
	LQ/KUG6NE.1P2M3G	1.350x900x850h	36,7			7.127,00
	LQ/KUG6NE.6G	1.350x900x850h	44,4		400V3N~ 50/60Hz	7.224,00
A scelta tra - Choice among - Wahl zwischen Elegibles entre - Choisir entre kW 3,5 - kW 5,5 - kW 7,4 - kW 9,0	LQ/KUG6NE....	1.350x900x850h	A richiesta Upon request		GN 2/1 mm.540x745x310h	.....

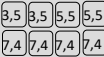
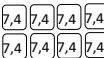
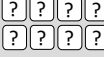
LADYQ900

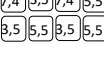
**CUCINE GAS**  
 GAS RANGES - GASHERDE - CUISINIÈRES GAZ - COCINAS GAS

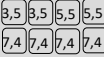
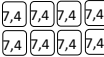
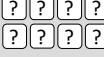
	Model	 (A x B x C) mm	kW	Burners	Oven	€
	LQ/KUG6FM.3P1M2G	1.350x900x850h	42,8		 kW 12	7.208,00
	LQ/KUG6FM.1P2M3G	1.350x900x850h	48,7			7.294,00
	LQ/KUG6FM.6G	1.350x900x850h	56,4			7.391,00
A scelta tra - Choice among - Wahl zwischen Elegibles entre - Choisir entre kW 3,5 - kW 5,5 - kW 7,4 - kW 9,0	LQ/KUG6FM....	1.350x900x850h	A richiesta Upon request		MAXI mm.935x550x310h	.....
	LQ/KUG8NG.3P3M2G	1.800x900x850h	59,0		2 X  kW 8,6	10.021,00
	LQ/KUG8NG.2P2M4G	1.800x900x850h	64,8			10.192,00
	LQ/KUG8NG.8G	1.800x900x850h	76,4			10.382,00
A scelta tra - Choice among - Wahl zwischen Elegibles entre - Choisir entre kW 3,5 - kW 5,5 - kW 7,4 - kW 9,0	LQ/KUG8NG....	1.800x900x850h	A richiesta Upon request		GN 2/1 mm.540x745x310h	.....
	LQ/KUG8NE.3P3M2G	1.800x900x850h	41,8		2 X  kW 5,48 400V3N~ 50/60Hz	10.661,00
	LQ/KUG8NE.2P2M4G	1.800x900x850h	47,6			10.834,00
	LQ/KUG8NE.8G	1.800x900x850h	59,2			11.023,00
A scelta tra - Choice among - Wahl zwischen Elegibles entre - Choisir entre kW 3,5 - kW 5,5 - kW 7,4 - kW 9,0	LQ/KUG8NE....	1.800x900x850h	A richiesta Upon request		GN 2/1 mm.540x745x310h	.....
Accessori in dotazione nr.1 griglia interna forno e nr. 1 riduzione fuoco - Accessories included nr.1 internal grid for oven and nr.1 reduction for burner - Zubehöre inbegriffen nr.1 Rost für Ofen und nr.1 Reduzierrost für Brenner - Accessoires inclus nr.1 grille pour four et nr.1 grille de réduction pour brûleur - Accesorios incluidos nr.1 parilla para horno y nr.1 rejilla reductora para quemador						

LADYQ900



## CUCINE WOK A GAS

GAS WOK RANGES - WOK GASHERDE - CUISINIÈRES WOK À GAZ - COCINAS WOK A GAS

LADYQ900

	Model	 C A B (A x B x C) mm	kW	Burners	Oven	€
	Bruciatori a scelta tra: - Burners available on request: - Brennern auf Anfrage von: - Brûleurs sur demande: - Quemadores bajo pedido:					
		Mod. "C" kW 9,5 - Ø mm.175				
Mod. "T" kW 14,0 - Ø mm.175						

Versione da banco - Bench model - Auf Tischmodell - Modèle à poser - Modelo de sobremesa

	LQ/CC/01.BB	400x900x275h	14,0	14		2.372,00
--	-------------	--------------	------	----	--	----------

Modello su vano a giorno - Model on open cabinet - Modell mit offenem Unterbau - Modèle sur meuble ouvert - Modelo abierto

	LQ/CC/01.BA	400x900x850h	14,0	14		2.850,00
--	-------------	--------------	------	----	--	----------

## PAELLERO GAS

PAELLERO - PAELLERO - PAELLERO - PAELLERO

	Model	 C A B (A x B x C) mm	kW	Burners	Oven	€
	LQ/PAE2BC	800x900x850h	27,0	27		5.433,00

## ACCESSORI- ACCESSORIES- ZUBEHÖRE- ACCESSOIRES- ACCESORIOS

	LQ/CH040	mm.400	Anta - Door - Tür - Porte - Puerta			205,00
--	----------	--------	------------------------------------	--	--	--------



**CUCINE TUTTAPIASTRA**

SOLID TOPS GAS RANGES - GLÜHLPLATTENHERDE - CUISINIÈRES PLAQUE COUP DE FEU À GAZ - PLACA RADIANTE

	Model	 A B C (A x B x C) mm	kW	Burners	Oven	€
	LQ/TPG4BB	800x900x275h	🔥 12,0			2.857,00
	LQ/TPG4BA	800x900x850h	🔥 12,0			3.519,00
	LQ/TPG4NG	800x900x850h	🔥 20,6		 GN 2/1 mm.540x745x310h	5.259,00
	LQ/TPG4NE	800x900x850h	🔥 12,0 ⚡ 5,48		 400V3N~ 50/60Hz GN 2/1 mm.540x745x310h	5.674,00
	LQ/TPG6BB	1.200x900x275h	🔥 24,9			3.853,00
	LQ/TPG6BA	1.200x900x850h	🔥 24,9			4.571,00
	LQ/TPG6NG	1.200x900x850h	🔥 33,5		 GN 2/1 mm.540x745x310h	6.421,00
	LQ/TPG6NE	1.200x900x850h	🔥 24,9 ⚡ 5,48		 400V3N~ 50/60Hz GN 2/1 mm.540x745x310h	6.912,00

LADYQ900



**CUCINE TUTTAPIASTRA**

SOLID TOPS GAS RANGES - GLÜHLPLATTENHERDE - CUISINIÈRES PLAQUE COUP  
DE FEU À GAZ - PLACA RADIANTE

LADYQ900

	Model	 (A x B x C) mm	kW	Burners	Oven	€
	LQ/TPG8BB	1.600x900x275h	37,8			7.332,00
	LQ/TPG8BA	1.600x900x850h	37,8			8.027,00
	LQ/TPG8NG	1.600x900x850h	55,0		2 X  GN 2/1 mm.540x745x310h	11.979,00
	LQ/TPG8NE	1.600x900x850h	37,8 10,96		2 X  kW 5,48 400V3N~ 50/60Hz GN 2/1 mm.540x745x310h	12.796,00



**CUCINE ELETTRICHE**

ELECTRIC RANGES - ELEKTROHERDE - CUISINIÈRES ELECTRIQUES - COCINAS ELÉCTRICAS

	Model	 A B C (A x B x C) mm	kW	Burners	Oven	€
	LQ/CQE2BB	400x900x275h	⚡ 8,0 400V3N~ 50/60Hz			2.523,00
	LQ/CQE4BB	800x900x275h	⚡ 16,0 400V3N~ 50/60Hz			4.134,00
	LQ/CQE6BB	1200x900x275h	⚡ 24,0 400V3N~ 50/60Hz			5.617,00
	LQ/CQE2BA	400x900x850h	⚡ 8,0 400V3N~ 50/60Hz			2.941,00
	LQ/CQE4BA	800x900x850h	⚡ 16,0 400V3N~ 50/60Hz			4.691,00
	LQ/CQE6BA	1200x900x850h	⚡ 24,0 400V3N~ 50/60Hz			6.601,00
	LQ/CQE4NE	800x900x850h	⚡ 21,48 400V3N~ 50/60Hz		 kW 5,48 400V3N~ 50/60Hz GN 2/1 mm.540x745x310h	6.662,00
	LQ/CQE6NE	1200x900x850h	⚡ 29,48 400V3N~ 50/60Hz		 kW 5,48 400V3N~ 50/60Hz GN 2/1 mm.540x745x310h	8.541,00

LADYQ900



**CUCINE ELETTRICHE VETROCERAMICA**  
 ELECTRIC GLASS CERAMIC RANGES - GLASKERAMIK ELEKTROHERDE -  
 CUISINIÈRES ÉLECTRIQUES VITROCÉRAMIQUE - COCINAS ELÉCTRICAS EN  
 VITROCERÁMICA

	Model	 (A x B x C) mm	kW	Burners	Oven	€
Versione da banco - Bench model - Auf Tischmodell - Modèle à poser - Modelo de sobremesa						
	LQ/CVE2BB	400x900x275h	6,0 400V3N~ 50/60Hz			3.244,00
	LQ/CVE4BB	800x900x275h	12,0 400V3N~ 50/60Hz			5.280,00
Modello su vano a giorno - Model on open cabinet - Modell mit offenem Unterbau - Modèle sur meuble ouvert - Modelo abierto						
	LQ/CVE2BA	400x900x850h	6,0 400V3N~ 50/60Hz			3.712,00
	LQ/CVE4BA	800x900x850h	12,0 400V3N~ 50/60Hz			5.888,00
Modello con forno elettrico - Model with electric oven - Modell mit Elektro-Backofen - Modèle avec four électrique - Modelo con horno eléctrico						
	LQ/CVE4NE	800x900x850h	17,48 400V3N~ 50/60Hz		 400V3N~ 50/60Hz GN 2/1 mm.540x745x310h	7.749,00

LADYQ900



## CUCINE A INDUZIONE







INDUCTION RANGES - INDUKTIONHERDE - CUISINIÈRES À INDUCTION -  
COCINAS ELÉCTRICAS A INDUCCIÓN

	Model	 A B C (A x B x C) mm	kW	Burners	Oven	€
Versione da banco - Bench model - Auf Tischmodell - Modèle à poser - Modelo de sobremesa						
	LQ/CUI2HBB	400x900x275h	⚡ 10,0 400V3N~ 50/60Hz			9.402,00
	LQ/CUI4HBB	800x900x275h	⚡ 20,0 400V3N~ 50/60Hz			16.404,00
Modello su vano a giorno - Model on open cabinet - Modell mit offenem Unterbau - Modèle sur meuble ouvert - Modelo abierto						
	LQ/CUI2HBA	400x900x850h	⚡ 10,0 400V3N~ 50/60Hz			9.795,00
	LQ/CUI4HBA	800x900x850h	⚡ 20,0 400V3N~ 50/60Hz			16.893,00























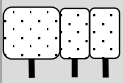





LADYQ900

## SCALDAPATATE

CHIP SCUTTLE - KARTOFFELWÄRMER - CHAUFFE FRITES - CALIENTA PATATAS

	Model	 A B C (A x B x C) mm	kW	Cap.	€
	LQ/SPE40BB	400x900x275h	⚡ 1,0 230V~ 50/60Hz	GN 1/1 	1.979,00
	LQ/SPE40BA	400x900x850h	⚡ 1,0 230V~ 50/60Hz	GN 1/1 	2.423,00

**FRIGGITRICI A GAS**  
 GAS FRYERS - GAS FRITTEUSEN - FRITEUSES GAZ - FREIDORAS A GAS















		Model	 (A x B x C) mm	kW	Baskets included	Lt.	€
Scambiatori di calore INTERNI / INTERNAL heat exchangers / Wärmetauschbrenner INNERHALB des Beckens / Échangeurs de chaleur INTERNES à la cuve / Intercambiadores de calor EN el tanque							
		LQ/FLG1V17	400x900x850h	16,5		17	3.810,00
		LQ/FLG1V22	400x900x850h	21,0		22	4.391,00
		LQ/FLG2V8	400x900x850h	11,6		8+8	5.139,00
		LQ/FLG2V17	800x900x850h	33,0		17+17	6.623,00
		LQ/FLG2V22	800x900x850h	42,0		22+22	7.513,00
Scambiatori di calore ESTERNI, vasca pulita / EXTERNAL heat exchangers, clean tank / Brenner an der AUßENSEITE des Beckens / Échangeurs de chaleur EXTÉRIEUR à la cuve / Intercambiadores de calor EXTERNOS a la cuba							
		LQ/FRG1V17	400x900x850h	16,0		17	4.104,00
		LQ/FRG1V21	400x900x850h	19,0		21	4.499,00
		LQ/FRG2V17	800x900x850h	32,0		17+17	6.914,00
		LQ/FRG2V21	800x900x850h	38,0		21+21	7.561,00
Cestelli, coperchio e n.1 vasca raccogli olio in dotazione - Equipped with baskets, lid and n.1 s/s oil draining tank - Inkl. Körbe, Deckel und n.1 Ölauffangbecken aus Edelstahl - Paniers, couvercle et n.1 bac de récupération huile en acier inoxydable inclus - Cestas, la tapa y n.1 barreño recoge aceite en acero inoxidable en dotación							

LADYQ900



## FRIGGITRICI ELETTRICHE

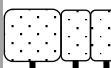

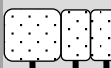

ELECTRIC FRYERS - ELEKTRO FRITTEUSEN - FRITEUSES ÉLECTRIQUE - FREIDORAS ELÉCTRICAS

		Model	 (A x B x C) mm	kW	Baskets included	Lt.	€
Resistenze rotanti in vasca / Rotating resistors in the tank / Heizkörper mit Dreh-System in Öl getaucht / Résistances immergées rotatives aux bacs / Resistencias rodantes en el tanque							
		LQ/FRE1V17	400x900x850h	16,5 400V3N~		17	3.282,00
		LQ/FRE1V21	400x900x850h	20,0 400V3N~		21	3.755,00
		LQ/FRE2V8	400x900x850h	14,0 400V3N~ 50/60Hz		8+8	4.080,00
		LQ/FRE2V17	800x900x850h	33,0 400V3N~ 50/60Hz		17+17	5.120,00
		LQ/FRE2V21	800x900x850h	40,0 400V3N~		21+21	5.852,00

LADYQ900

Cestelli, coperchio e n.1 vasca raccogli olio in dotazione - Equipped with baskets, lid and n.1 s/s oil draining tank - Inkl. Körbe, Deckel und n.1 Ölauffangbecken aus Edelstahl - Paniers, couvercle et n.1 bac de récupération huile en acier inoxydable inclus - Cestas, la tapa y n.1 barreño recoge aceite en acero inoxidable en dotación





## ACCESSORI- ACCESSORIES- ZUBEHÖRE- ACCESSOIRES- ACCESORIOS

	21/99600133	140x300x120h	cestello 1/2 per vasca cap.Lt 17 Mod. FLG/FRG/FRE - basket 1/2 for tank cap. Lt.17 Mod. FLG/FRG/FRE	110,00
	21/99600136	140x400x120h	cestello 1/2 per vasca cap.Lt 21/22 Mod. FLG/FRG/FRE - basket 1/2 for tank cap. Lt.21/22 Mod. FLG/FRG/FRE	125,00
	21/99600130	120x300x120h	cestello per vasca cap.Lt 8 Mod. FLG/FRE - basket for tank cap. Lt.8 Mod. FLG/FRE	110,00
	21/99600134	290x300x120h	cestello 1/1 per vasca cap.Lt 17 Mod. FLG/FRG/FRE - basket 1/1 for tank cap. Lt.17 Mod. FLG/FRG/FRE	121,00
	21/99600135	400x290x120h	cestello 1/1 per vasca cap.Lt 21/22 Mod. FLG/FRG/FRE - basket 1/1 for tank cap. Lt.21/22 Mod. FLG/FRG/FRE	159,00
	WD/99600001		vasca raccogli olio supplementare - additional oil draining tank	246,00



## CUOCIPASTA A GAS





GAS PASTA COOKERS - GAS NUDELKOCHER - CUISEUR À PÂTES GAZ - CUECE-PASTAS GAS

	Model		kW	Lt.	Cap.	€
	LQ/CPG1V40	400x900x850h	15,0	40	1/1	3.831,00
	LQ/CPG2V80	800x900x850h	30,0	40+40	1/1 1/1	6.188,00

Cestelli e coperchi non in dotazione - Baskets and lids are not included - Körbe und Deckeln im Preis nicht imbegriffen - Paniers et couvercles pas compris dans le prix - Cestas y la tapas no incluidas en el precio

## CUOCIPASTA ELETTRICO

ELECTRIC PASTA COOKERS - ELEKTRO NUDELKOCHER - CUISEUR À PÂTES ÉLECTRIQUE - CUECE-PASTAS ELÉCTRICOS

	Model		kW	Lt.	Cap.	€
	LQ/CPE2V1	400x900x850h	12,0 400V3N~ 50/60Hz	40	1/1	3.962,00
	LQ/CPE4V2	800x900x850h	24,0 400V3N~ 50/60Hz	40+40	1/1 1/1	6.6546,00













Cestelli e coperchi non in dotazione - Baskets and lids are not included - Körbe und Deckeln im Preis nicht imbegriffen - Paniers et couvercles pas compris dans le prix - Cestas y la tapas no incluidas en el precio

LADYQ900



## ACCESSORI PER CUOCIPASTA

ACCESSORIES FOR PASTA COOKERS - ZUBEHÖRE FÜR NUDELKOCHER - ACCESSOIRES  
POUR CUISEUR À PÂTES - ACCESORIOS PARA CUECE-PASTAS



	Model	 A B C (A x B x C) mm	kW	Lt.	Cap.	€
<b>ACCESSORI- ACCESSORIES- ZUBEHÖRE- ACCESSOIRES- ACCESORIOS</b>						
	<b>SET 900CESA</b> 3 X 21/99900081	nr.3 x 288x163x215h			nr.3 cestelli inox GN 1/3 nr.3 s/s baskets GN 1/3	<b>504,00</b>
	<b>SET 900CESB</b> 1 X 21/99900147 1 X 21/99900148 2 X 21/99900081	nr.2 x 143x163x215h + nr.2 x 288x163x215h			nr.2 cestelli inox 1/6 + nr.2 cestelli inox GN 1/3 nr.2 s/s baskets GN 1/6 + nr.2 s/s basket GN 1/3	<b>600,00</b>
	<b>SET 900CESC</b> 1 X 21/99900081 2 X 21/99900147 2 X 21/99900148	nr.4 x 143x163x215h + nr.1 x 288x163x215h			nr.1 cestello inox GN 1/3 + nr.4 cestelli inox GN 1/6 nr.1 s/s baskets GN 1/3 + nr.4 s/s baskets GN 1/6	<b>969,00</b>
	<b>SET 900CESD</b> 3 X 21/99900147 3 X 21/99900148	nr.6 x 143x163x215h			nr.6 cestelli inox 1/6 nr.6 s/s baskets 1/6	<b>792,00</b>
	<b>SET 900CESE</b> 2 X 21/99900070	nr.2 x 302x253x215h			nr.2 cestelli inox 1/2 nr.2 s/s baskets 1/2	<b>448,00</b>
	<b>SET 900CESF</b> 1 X 21/99900060	nr.1 x 298x488x215h			nr.1 cestello inox GN 1/1 nr.1 s/s basket GN 1/1	<b>349,00</b>
	<b>23/99906199</b>	610x270			coperchio vasca inox lt. 40 s/s lid for tank lt. 40	<b>116,00</b>
	<b>21/99900179</b>	d. 145x200h			cestello tondo d. 145 mm - round s/s basket d. 145 mm	<b>136,00</b>
	<b>SET700CESH</b> 6 x 21/99900179	nr. 6 x d. 145x200h			nr. 6 cestelli tondi d. 145 mm - nr. 6 round s/s baskets d. 145 mm	<b>815,00</b>
	<b>23/99909210</b>				supporto cestelli tondi per vasca GN 1/1 - support for round baskets - tank GN 1/1	<b>132,00</b>

LADYQ900

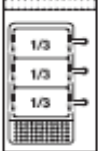

## CUOCIPASTA ELETTRICO FASTPASTA

ELECTRIC PASTA COOKERS FASTPASTA - ELEKTRO NUDELKOCHER FASTPASTA -  
 CUISEUR À PÂTES FASTPASTA ÉLECTRIQUE - CUECE-PASTAS FASTPASTA  
 ELÉCTRICOS



	Model	 (A x B x C) mm	kW	Set baskets included	€
Con nr.3 sollevamenti per vasca - With nr.3 lifters for each tank - Mit nr.3 Körbeheber für jedes Becken - Avec nr.3 relevages pour chaque cuve - Con nr.3 levantamientos para cada cuba					
	LQ/CPE2V1-1FP-A	500x900x850h	⚡ 12,6  400V3N~ 50/60Hz	 Cap. Lt. 40	9.770,00
	LQ/CPE2V1-1FP-B	500x900x850h	⚡ 12,6  400V3N~ 50/60Hz	 Cap. Lt. 40	9.983,00
	LQ/CPE2V1-1FP-C	500x900x850h	⚡ 12,6  400V3N~ 50/60Hz	 Cap. Lt. 40	10.197,00
Con nr.6 sollevamenti per vasca - With nr.6 lifters for each tank - Mit nr.6 Körbeheber für jedes Becken - Avec nr.6 relevages pour chaque cuve - Con nr.6 levantamientos para cada cuba					
	LQ/CPE4V2-2FP-AA	1.000x900x850h	⚡ 25,2  400V3N~ 50/60Hz	 Cap. Lt. 40+40	16.737,00
	LQ/CPE4V2-2FP-BB	1.000x900x850h	⚡ 25,2  400V3N~ 50/60Hz	 Cap. Lt. 40+40	17.166,00
	LQ/CPE4V2-2FP-CC	1.000x900x850h	⚡ 25,2  400V3N~ 50/60Hz	 Cap. Lt. 40+40	17.595,00

LADYQ900





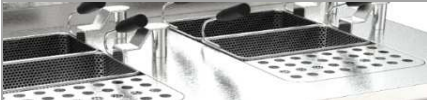

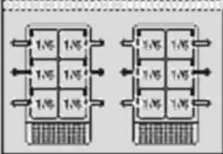
## CUOCIPASTA ELETTRICO FASTPASTA

ELECTRIC PASTA COOKERS FASTPASTA - ELEKTRO NUDELKOCHER FASTPASTA -  
 CUISEUR À PÂTES FASTPASTA ÉLECTRIQUE - CUECE-PASTAS FASTPASTA  
 ELÉCTRICOS

	Model	 C A B (A x B x C) mm	kW	Set baskets included	€
	Con nr.12 sollevamenti per vasca - With nr.12 lifters for each tank - Mit nr.12 Körbeheber für jedes Becken - Avec nr.12 relevages pour chaque cuve - Con nr.12 levantamientos para cada cuba				
	LQ/CPE4V2-4FP-DD	1.200x900x850h	⚡ 24,4  400V3N~ 50/60Hz	  Cap. Lt. 40+40	26.629,00

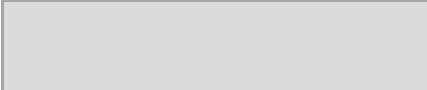
## ACCESSORI



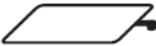







ACCESSORIES- ZUBEHÖRE- ACCESSOIRES- ACCESORIOS

	Model	 C A B (A x B x C) mm	Description	€
	21/99900131	150x150x215h	Cestello GN 1/6 con manico a sinistra S/s basket GN 1/6 with left-side handle	139,00
	21/99900130	150x150x215h	Cestello GN 1/6 con manico a destra S/s basket GN 1/6 with right-side handle	139,00
	21/99900079	302x168x215h	Cestello GN 1/3 con nr.2 manici S/s basket GN 1/3 with nr.2 handles	178,00
	WA/99908659	155x304xØ6	Supporto per sollevatore per 2 GN 1/6 Lift support for 2 GN 1/6 Aufsatz für Hebevorrichtung für 2 GN 1/6 Support pour élévateur pour 2 GN 1/6 Suporte para levantador para 2 GN 1/6	83,00
	CPRAM		Riempimento e rabbocco automatico acqua in vasca Automatic water re-filling in tank Automatisches Füllen und Nachfüllen des Wassers in Wanne Remplissage et remise à niveau automatique de l'eau dans la cuve Llenado y relleno automático de agua en la cuba	903,00  ogni vasca each tank jeder Becken chaque cuve cada cuba

LADYQ900

**BAGNOMARIA ELETTRICI**

ELECTRIC BAINS-MARIE- ELEKTRO WASSERBÄDER- BAINS-MARIE ÉLECTRIQUE - BAÑOS MARÍA ELÉCTRICO

	Model		kW	Cap.	€
	Modello su vano a giorno - Model on open cabinet - Modell mit offenem Unterbau - Modèle sur meuble ouvert - Modelo abierto				
	LQ/BME1BA	400x900x850h	⚡ 1,8 230V~ 50/60Hz	GN 1/1+1/3 	<b>2.444,00</b>
	LQ/BME2BA	800x900x850h	⚡ 3,6 230V~ 50/60Hz	GN 2/1+2X1/3 	<b>3.137,00</b>
Cestelli e coperchi non in dotazione - Baskets and lids are not included - Körbe und Deckeln im Preis nicht imbegriffen - Paniers et couvercles pas compris dans le prix - Cestas y la tapas no incluidas en el precio					
<b>ACCESSORI- ACCESSORIES- ZUBEHÖRE- ACCESSOIRES- ACCESORIOS</b>					
	LQ/CH040	mm.400	Anta - Door - Tür - Porte - Puerta		<b>205,00</b>
	56/89900006	530x325x150h	Vaschetta inox - S/s GN 1/1 cap. lt 21,3		<b>84,00</b>
	56/89900060	354x325x150h	Vaschetta inox - S/s GN 2/3 cap. lt 13,2		<b>60,00</b>
	56/89900030	265x325x150h	Vaschetta inox - S/s GN 1/2 cap. lt 9,7		<b>50,00</b>
	56/89900010	176x325x150h	Vaschetta inox - S/s GN 1/3 cap. lt 5,8		<b>41,00</b>
	56/89900040	162x265x150h	Vaschetta inox - S/s GN 1/4 cap. lt 4,1		<b>32,00</b>
	56/89900020	162x176x150h	Vaschetta inox - S/s GN 1/6 cap. lt 2,4		<b>31,00</b>
	56/89901002	530x325	Coperchio inox - S/s lid GN 1/1		<b>28,00</b>
	56/89901006	354x325	Coperchio inox - S/s lid GN 2/3		<b>26,00</b>
	56/89901001	265x325	Coperchio inox - S/s lid GN 1/2		<b>21,00</b>
	56/89901007	176x325	Coperchio inox - S/s lid GN 1/3		<b>17,00</b>
	56/89901003	162x265	Coperchio inox - S/s lid GN 1/4		<b>14,00</b>
	56/89901000	162x176	Coperchio inox - S/s lid GN 1/6		<b>15,00</b>
	23/99600003		Divisorio bacinelle - Dividing element for GN		<b>30,00</b>

LADYQ900



## VAPORIERA DIM SUM ELETTRICA

ELECTRIC DIM SUM STEAMER - ELEKTRISCHER DIM SUM DAMPFGARER -  
 CUISEUR VAPEUR POUR DIM SUM ELECTRIQUE - VAPORRERA DIM SUM  
 ELÉCTRICA











	Model	 (A x B x C) mm	kW	Cap./Lt.	Baskets included	€
	Modello su vano a giorno - Model on open cabinet - Modell mit offenem Unterbau - Modèle sur meuble ouvert - Modelo abierto					
	LQ/DKE400BA	400x900x850h	⚡ 6,0 400V3N~ 50/60Hz	GN 1/1+1/3 Lt.38		4.594,00
	LQ/DSE400BA	400x900x850h	⚡ 12,0 400V3N~ 50/60Hz	GN 1/1+1/3 Lt.38		4.741,00
	LQ/DKE800BA	800x900x850h	⚡ 12,0 400V3N~ 50/60Hz	GN 2/1+2x1/3 Lt.78		5.672,00
	LQ/DSE800BA	800x900x850h	⚡ 24,0 400V3N~ 50/60Hz	GN 2/1+2x1/3 Lt.78		6.082,00
Cestelli in bambù in dotazione - Equipped with bamboo containers - Inkl. Bambù Behälter - Bacs bambù compris dans le prix - Recipientes bambù en dotación						
<b>ACCESSORI- ACCESSORIES- ZUBEHÖRE- ACCESSOIRES- ACCESORIOS</b>						
	LQ/CH040	mm.400	Anta - Door - Tür - Porte - Puerta			205,00
	21/99900369	Ø 150 mm	Set cestelli in bambù (3 cesti + 1 coperchio) Bambù set (3 baskets + 1 lid) Bambus Set (3 Körbe + 1 Deckel)			53,00
	21/99900379	Ø 180 mm	Set cestelli in bambù (3 cesti + 1 coperchio) Bambù set (3 baskets + 1 lid) Bambus Set (3 Körbe + 1 Deckel)			60,00
	21/99900389	Ø 210 mm	Set cestelli in bambù (3 cesti + 1 coperchio) Bambù set (3 baskets + 1 lid) Bambus Set (3 Körbe + 1 Deckel)			68,00

**LADYQ900**



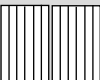

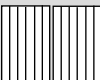

## GRIGLIE A PIETRA LAVICA

LAVASTONE GRILL - LAVASTEIN-GRILL - GRILLES PIERRE VOLCANIQUE - PARRILLAS DE PIEDRA VOLCÁNICA

	Model	 A B C (A x B x C) mm	kW	Grid	Kg. Lava rock	€
Versione da banco - Bench model - Aufschmodell - Modèle à poser - Modelo de sobremesa						
	LQ/BS1BB	400x900x275h	11,0		9	2.684,00
	LQ/BS2BB	800x900x275h	22,0		18	4.106,00
Modello su vano a giorno / Model on open cabinet / Modell mit offenem Unterbau / Modèle sur meuble ouvert / Modelo abierto						
	LQ/BS1BA	400x900x850h	11,0		9	3.118,00
	LQ/BS2BA	800x900x850h	22,0		18	4.620,00

LADYQ900

ACCESSORI- ACCESSORIES- ZUBEHÖRE- ACCESSOIRES- ACCESORIOS						
	LQ/CH040	mm.400	Anta - Door - Tür - Porte - Puerta			205,00
	15/99901889		Pietra lavica - Lava rock - Lavastein - Lave volcanique - Lava Volcànica			12,00 / Kg
	21/99900004	for Mod. BS1	Griglia a canaletto per carne - Steel "V" shape cooking grid for meat			276,00
	21/99900003	for Mod. BS2	Griglia a canaletto per carne - Steel "V" shape cooking grid for meat			545,00
	21/99900002	for Mod. BS1	Griglia in tondino Ø mm.8 per pesce - Steel round cooking grid Ø mm.8 for fish			316,00
	21/99900001	for Mod. BS2	Griglia in tondino Ø mm.8 per pesce - Steel round cooking grid Ø mm.8 for fish			623,00



## FRY-TOP GAS

GAS GRIDDLE PLATES - GAS GRILLPLATTEN - FRY-TOP GAZ - FRY-TOP A GAS

LADYQ900

	Model	F K C		kW	Ue	Extra Ue	Dim.cooking plate mm.	€
	LQ/FTG2BBL	F	400x900x275h	6,9	•	•	375x640	2.420,00
	LQ/FTG2BBLK	K					375x640	2.787,00
	LQ/FTG2BBLC	C					375x640	2.836,00
	LQ/FTG2BBR	F	400x900x275h	6,9	•	•	375x640	2.481,00
	LQ/FTG2BBRK	K					375x640	2.846,00
	LQ/FTG2BBRC	C					375x640	2.895,00
	LQ/FTG4BBL	F	800x900x275h	13,8	•	•	775x640	3.070,00
	LQ/FTG4BBLK	K					775x640	3.816,00
	LQ/FTG4BBLC	C					775x640	3.926,00
	LQ/FTG4BBR	F	800x900x275h	13,8	•	•	775x640	3.263,00
	LQ/FTG4BBRK	K					775x640	4.029,00
	LQ/FTG4BBRC	C					775x640	4.115,00
	LQ/FTG4BBM	F	800x900x275h	13,8	•	•	775x640	3.173,00
	LQ/FTG4BBMK	K					775x640	3.943,00
	LQ/FTG4BBMC	C					775x640	4.081,00

**F** - Piastra in acciaio semi-dolce - Semi-mild steel plate - Halbweiche Stahlplatte - Plaque en acier demi-doux - Plancha de acero semi-suave

**K** - Piastra conforme a normativa CE 1935/2004-MOCA - Plate in compliance with EC 1935/2004 Regulation-FCM - LKM-Platte konform mit CE 1935/2004 - Plaque en ligne avec le règlement CE 1935/2004-MCDA - Plancha conforme al reglamento CE 1935/2004-MOCA







**C** - Piastra cromata - Chromium plate version - Ausführung mit verchromte Platte - Version chromée - Versión cromada



## FRY-TOP GAS

GAS GRIDDLE PLATES - GAS GRILLPLATTEN - FRY-TOP GAZ - FRY-TOP A GAS

LADYQ900

	Model	F K C	 A B C (A x B x C) mm	kW	UE	Extra UE	Dim.cooking plate mm.	€
	LQ/FTG2BAL	F	400x900x850h	6,9	•	•	375x640	2.886,00
	LQ/FTG2BALK	K					375x640	3.253,00
	LQ/FTG2BALC	C					375x640	3.307,00
	LQ/FTG2BAR	F	400x900x850h	6,9	•	•	375x640	2.954,00
	LQ/FTG2BARK	K					375x640	3.315,00
	LQ/FTG2BARC	C					375x640	3.567,00
	LQ/FTG4BAL	F	800x900x850h	13,8	•	•	775x640	3.707,00
	LQ/FTG4BALK	K					775x640	4.457,00
	LQ/FTG4BALC	C					775x640	4.571,00
	LQ/FTG4BAR	F	800x900x850h	13,8	•	•	775x640	3.903,00
	LQ/FTG4BARK	K					775x640	4.682,00
	LQ/FTG4BARC	C					775x640	4.722,00
	LQ/FTG4BAM	F	800x900x850h	13,8	•	•	775x640	3.797,00
	LQ/FTG4BAMK	K					775x640	4.582,00
	LQ/FTG4BAMC	C					775x640	4.643,00

**F** - Piastra in acciaio semi-dolce - Semi-mild steel plate - Halbweiche Stahlplatte - Plaque en acier demi-doux - Plancha de acero semi-suave

**K** - Piastra conforme a normativa CE 1935/2004-MOCA - Plate in compliance with EC 1935/2004 Regulation-FCM - LKM-Platte konform mit CE 1935/2004 - Plaque en ligne avec le règlement CE 1935/2004-MCDA - Plancha conforme al reglamento CE 1935/2004-MOCA

**C** - Piastra cromata - Chromium plate version - Ausführung mit verchromte Platte - Version chromée - Versión cromada



## FRY-TOP ELETTRICO

ELECTRIC GRIDDLE PLATES - ELEKTRO GRILLPLATTEN - FRY-TOP ÉLECTRIQUE - FRY-TOP ELÉCTRICOS

LADYQ900

	Model	F K C	 (A x B x C) mm	kW	Ue	Extra Ue	Dim.cooking plate mm.	€
	LQ/FTE2BBL	F	400x900x275h	6,0 400V3N~ 50/60Hz	●	●	375x640	2.575,00
	LQ/FTE2BBLK	K					375x640	2.939,00
	LQ/FTE2BBLC	C					375x640	3.004,00
	LQ/FTE2BBR	F	400x900x275h	6,0 400V3N~ 50/60Hz	●	●	375x640	2.688,00
	LQ/FTE2BBRK	K					375x640	3.050,00
	LQ/FTE2BBRC	C					375x640	3.232,00
	LQ/FTE4BBL	F	800x900x275h	12,0 400V3N~ 50/60Hz	●	●	775x640	3.385,00
	LQ/FTE4BBLK	K					775x640	4.127,00
	LQ/FTE4BBLC	C					775x640	4.251,00
	LQ/FTE4BBR	F	800x900x275h	12,0 400V3N~ 50/60Hz	●	●	775x640	3.610,00
	LQ/FTE4BBRK	K					775x640	4.381,00
	LQ/FTE4BBRC	C					775x640	4.449,00
	LQ/FTE4BBM	F	800x900x275h	12,0 400V3N~ 50/60Hz	●	●	775x640	3.491,00
	LQ/FTE4BBMK	K					775x640	4.260,00
	LQ/FTE4BBMC	C					775x640	4.354,00

F - Piastra in acciaio semi-dolce - Semi-mild steel plate - Halbweiche Stahlplatte - Plaque en acier demi-doux - Plancha de acero semi-suave

K - Piastra conforme a normativa CE 1935/2004-MOCA - Plate in compliance with EC 1935/2004 Regulation-FCM - LKM-Platte konform mit CE 1935/2004 - Plaque en ligne avec le règlement CE 1935/2004-MCDA - Plancha conforme al reglamento CE 1935/2004-MOCA







C - Piastra cromata - Chromium plate version - Ausführung mit verchromte Platte - Version chromée - Versión cromada



## FRY-TOP ELETTRICO

ELECTRIC GRIDDLE PLATES - ELEKTRO GRILLPLATTEN - FRY-TOP ÉLECTRIQUE - FRY-TOP ELÉCTRICOS

LADYQ900

	Model	F K C	 C A B (A x B x C) mm	kW	UE	Extra UE	Dim.cooking plate mm.	€
	LQ/FTE2BAL	F	400x900x850h	6,0 400V3N~ 50/60Hz	•	•	375x640	2.985,00
	LQ/FTE2BALK	K					375x640	3.394,00
	LQ/FTE2BALC	C					375x640	3.395,00
	LQ/FTE2BAR	F	400x900x850h	6,0 400V3N~ 50/60Hz	•	•	375x640	3.076,00
	LQ/FTE2BARK	K					375x640	3.450,00
	LQ/FTE2BARC	C					375x640	3.685,00
	LQ/FTE4BAL	F	800x900x850h	12,0 400V3N~ 50/60Hz	•	•	775x640	4.003,00
	LQ/FTE4BALK	K					775x640	4.766,00
	LQ/FTE4BALC	C					775x640	4.874,00
	LQ/FTE4BAR	F	800x900x850h	12,0 400V3N~ 50/60Hz	•	•	775x640	4.308,00
	LQ/FTE4BARK	K					775x640	5.098,00
	LQ/FTE4BARC	C					775x640	5.083,00
	LQ/FTE4BAM	F	800x900x850h	12,0 400V3N~ 50/60Hz	•	•	775x640	4.114,00
	LQ/FTE4BAMK	K					775x640	4.900,00
	LQ/FTE4BAMC	C					775x640	4.998,00

F - Piastra in acciaio semi-dolce - Semi-mild steel plate - Halbweiche Stahlplatte - Plaque en acier demi-doux - Plancha de acero semi-suave







K - Piastra conforme a normativa CE 1935/2004-MOCA - Plate in compliance with EC 1935/2004 Regulation-FCM - LKM-Platte konform mit CE 1935/2004 - Plaque en ligne avec le règlement CE 1935/2004-MCDA - Plancha conforme al reglamento CE 1935/2004-MOCA

C - Piastra cromata - Chromium plate version - Ausführung mit verchromte Platte - Version chromée - Versión cromada

**ELEMENTI NEUTRI**

NEUTRAL UNITS- ARBEITSELEMENTE - ELEMENTS NEUTRES - MUEBLES

NEUTROS





	Model	 (A x B x C) mm		€
Versione da banco - Bench model - Auf Tischmodell - Modèle à poser - Modelo de sobremesa				
	LQ/ENN2BB	400x900x275h		<b>939,00</b>
	LQ/ENN2CB	400x900x275h	con 1 cassetto GN 1/1 - with 1 drawer GN 1/1- mit 1 Schublade GN 1/1 - avec 1 tiroir GN 1/1 - con 1 cajón GN 1/1	<b>1.473,00</b>
	LQ/ENN4BB	800x900x275h		<b>1.302,00</b>
	LQ/ENN4CB	800x900x275h	con 1 cassetto GN 2/1 - with 1 drawer GN 2/1- mit 1 Schublade GN 2/1 - avec 1 tiroir GN 2/1 - con 1 cajón GN 2/1	<b>1.880,00</b>
Modello su vano a giorno - Model on open cabinet - Modell mit offenem Unterbau - Modèle sur meuble ouvert - Modelo abierto				
	LQ/ENN2BA	400x900x850h		<b>1.357,00</b>
	LQ/ENN2CA	400x900x850h	con 1 cassetto GN 1/1 - with 1 drawer GN 1/1- mit 1 Schublade GN 1/1 - avec 1 tiroir GN 1/1 - con 1 cajón GN 1/1	<b>1.954,00</b>
	LQ/ENN4BA	800x900x850h		<b>1.941,00</b>
	LQ/ENN4CA	800x900x850h	con 1 cassetto GN 2/1 - with 1 drawer GN 2/1- mit 1 Schublade GN 2/1 - avec 1 tiroir GN 2/1 - con 1 cajón GN 2/1	<b>2.519,00</b>
<b>ACCESSORI- ACCESSORIES- ZUBEHÖRE- ACCESSOIRES- ACCESORIOS</b>				
	LQ/CH040	mm.400	Anta - Door - Tür - Porte - Puerta	<b>205,00</b>

LADYQ900



## PENTOLE GAS



GAS BOILING PANS - GAS KOCHKESSEL - MARMITES À GAZ - MARMITAS A GAS

	Model	 A B C (A x B x C) mm	kW	Lt.	Tank dim.	€
Riscaldamento diretto - Direct heating - Direkte Beheizung - Chauffage direct - Calentamiento directo						
	LQ/PDG410	800x900x850h	21,0	102/113	∅ 600x415 mm	7.325,00
	LQ/PDG415	800x900x850h	21,0	139/150	∅ 600x540 mm	7.519,00
Riscaldamento indiretto - Indirect heating - Indirekte Beheizung - Chauffage indirect - Calentamiento indirecto						
	LQ/PIG410	800x900x850h	21,0	102/113	∅ 600x415 mm	9.339,00
	LQ/PIG415	800x900x850h	21,0	139/150	∅ 600x540 mm	9.744,00

LADYQ900

## PENTOLE ELETTRICHE

ELECTRIC BOILING PANS - ELEKTRO KOCHKESSEL - MARMITES ÉLECTRIQUES - MARMITAS ÉLECTRICAS





	Model	 A B C (A x B x C) mm	kW	Lt.	Tank dim.	€
Riscaldamento indiretto - Indirect heating - Indirekte Beheizung - Chauffage indirect - Calentamiento indirecto						
	LQ/PIE410	800x900x850h	16,0 400V3N~ 50/60Hz	102/113	∅ 600x415 mm	9.147,00
	LQ/PIE415	800x900x850h	18,0 400V3N~ 50/60Hz	139/150	∅ 600x540 mm	9.513,00

Cestelli non in dotazione - Baskets are not included - Körbe im Preis nicht imbegriffen - Paniers pas compris dans le prix - Cestas no incluidas en el precio

	Model	 (A x B x C) mm	Description	€
<b>ACCESSORI- ACCESSORIES- ZUBEHÖRE- ACCESSOIRES- ACCESORIOS</b>				
	<b>CES1100</b>	ø mm.560x345h Lt. 100	Cestello per pentole ad 1 settore Basket for boiling pans 1 sector Körbe für Kochkesseln 1 Sektor Panier pour marmites 1 secteur Cesta para marmitas 1 sector	<b>961,00</b>
	<b>CES1150</b>	ø mm.560x470h Lt. 150	Cestello per pentole ad 1 settore Basket for boiling pans 1 sector Körbe für Kochkesseln 1 Sektor Panier pour marmites 1 secteur Cesta para marmitas 1 sector	<b>1001,00</b>
	<b>CES2100</b>	ø mm.560x345h Lt. 100	Cestello per pentole a 2 settori Basket for boiling pans 2 sectors Körbe für Kochkesseln 2 Sektoren Panier pour marmites 2 secteurs Cesta para marmitas 2 sectores	<b>1.347,00</b>
	<b>CES2150</b>	ø mm.560x470h Lt. 150	Cestello per pentole a 2 settori Basket for boiling pans 2 sectors Körbe für Kochkesseln 2 Sektoren Panier pour marmites 2 secteurs Cesta para marmitas 2 sectores	<b>1.428,00</b>
	<b>CES3100</b>	ø mm.560x345h Lt. 100	Cestello per pentole a 3 settori Basket for boiling pans 3 sectors Körbe für Kochkesseln 3 Sektoren Panier pour marmites 3 secteurs Cesta para marmitas 3 sectores	<b>1.754,00</b>
	<b>CES3150</b>	ø mm.560x470h Lt. 150	Cestello per pentole a 3 settori Basket for boiling pans 3 sectors Körbe für Kochkesseln 3 Sektoren Panier pour marmites 3 secteurs Cesta para marmitas 3 sectores	<b>1.877,00</b>

**BRASIERE GAS**





GAS TILTING BRATT PANS - GAS KIPPBRATPFANNEN - SAUTEUSES  
 BASCULANTES À GAZ - SARTENES BASCULANTES A GAS

	Model	 (A x B x C) mm	kW	Lt.	Bottom type	€
Sollevamento manuale - Manual tilt - Manuelle Kippung - Renversement manual - Elevación manual						
	<b>LQ/BRG180M</b>	800x900x850h	20,0	70/86	AISI 304 mm.12	<b>7.806,00</b>
Sollevamento motorizzato - Electric tilt - Motorgetriebene Kippung - Renversement motorisé - Elevación motorizada						
	<b>LQ/BRG180A</b>	800x900x850h	20,0	70/86	AISI 304 mm.12	<b>9.742,00</b>





LADYQ900

**BRASIERE ELETTRICHE**

ELECTRIC TILTING BRATT PANS - ELEKTRO KIPPBRATPFANNEN - SAUTEUSES  
 BASCULANTES ÉLECTRIQUES - SARTENES BASCULANTES ELÉCTRICAS

	Model	 (A x B x C) mm	kW	Lt.	Bottom type	€
Sollevamento manuale - Manual tilt - Manuelle Kippung - Renversement manual - Elevación manual						
	<b>LQ/BRE180M</b>	800x900x850h	10,0	70/86	AISI 304 mm.12	<b>8.170,00</b>
Sollevamento motorizzato - Electric tilt - Motorgetriebene Kippung - Renversement motorisé - Elevación motorizada						
	<b>LQ/BRE180A</b>	800x900x850h	10,0	70/86	AISI 304 mm.12	<b>10.098,00</b>

**ACCESSORI**  
 ACCESSORIES- ZUBEHÖRE- ACCESSOIRES- ACCESORIOS

	Model	 (A x B x C) mm	Description	€
<b>ACCESSORI- ACCESSORIES- ZUBEHÖRE- ACCESSOIRES- ACCESORIOS</b>				
	<b>LQ/CH040</b>	mm.400	Anta - Door - Tür - Porte - Puerta	<b>205,00</b>
	<b>LQ/EX040</b>	400x70x150h	Prolunga camino - Flue extentions	<b>165,00</b>
	<b>LQ/EX045</b>	450x70x150h	Prolunga camino - Flue extentions	<b>176,00</b>
	<b>LQ/EX080</b>	800x70x150h	Prolunga camino - Flue extentions	<b>243,00</b>
	<b>LQ/EX090</b>	900x70x150h	Prolunga camino - Flue extentions	<b>261,00</b>
	<b>LQ/EX120</b>	1.200x70x150h	Prolunga camino - Flue extentions	<b>323,00</b>
	<b>LQ/EX135</b>	1.350x70x150h	Prolunga camino - Flue extentions	<b>350,00</b>
	<b>LQ/EX160</b>	1.600x70x150h	Prolunga camino - Flue extentions	<b>402,00</b>
	<b>LQ/EX180</b>	1.800x70x150h	Prolunga camino - Flue extentions	<b>433,00</b>
	<b>15/99901029</b>		Riduzione per griglia Reduction grid for grid Reduzierrost für Rost Grille de reduction pour support poele Rejilla reductore para parrilla	<b>50,00</b>
	<b>21/GX2/1</b>	530x650	Griglia cromata interna forno - Chromed grid for oven <b>Mod. LO/LE</b>	<b>75,00</b>
	<b>21/99600089</b>	885x450	Griglia cromata interna forno - Chromed grid for oven <b>Mod. FM</b>	<b>110,00</b>
	<b>SET4RUOTE</b> <b>2 X 63/99000143</b> <b>2 X 63/99000144</b>	Ø mm.100	Set nr.4 ruote Ø mm.100 (nr.2 con freno) Set of nr.4 castors Ø mm.100 (nr.2 with breaks) Set von nr.4 Räder Ø mm.100 (nr.2 mit Bremse) Set de 4 roues Ø mm.100 (nr.2 avec freins) Set de 4 ruedas Ø mm.100 (nr.1 con frenos)	<b>400,00</b>
	<b>COP.PIE</b>	H. mm.110	Zoccolo inox copertura piedi Cover for feet in stainless steel Fußbende für Füße aus Edelstahl Couverture pour les pieds en acier inox Sueco para patas en acero inoxidable	<b>292,00</b> AL METRO LINEARE - FOR LINEAR METER - FÜR LINEARMETER - AU METRE LINÉAIRE - POR METRO LINEAR



# AiSHA





AİSHA

AİSHA GAS

GAS AİSHA - GAS AİSHA - AİSHA A GAZ - AİSHA A GAS



	Model	 (A x B x C) mm	kW	Cap.	€
	LQ/CCG1V80	800X900X850	 15,0	<div style="border: 1px solid black; border-radius: 10px; padding: 2px 5px; display: inline-block;">1/1</div> Lt. 40	6.068,00

Adatto per cottura al vapore di cous cous, riso, e verdure con l'utilizzo di particolari vassoi forati.

Struttura interamente realizzata in acciaio inox AISI 304 18/10 scotch brite.

Piano di lavoro arrotondato in acciaio inox AISI 304 18/10 spessore 2,0 mm con camino posteriore incorporato.

Piano con inserita n. 1 vasca di cottura in acciaio inox AISI 304, GN 1/1, capacità 40,0 lt, con inserito vassoio GN 1/1 forata h. 100 a sinistra, n. 1 vassoio estraibile GN 1/1 h.150 a destra

Rubinetto di carico e rabbocco acqua in vasca posizionato sul piano, con comando sul cruscotto.

Scarico realizzato in tubo di acciaio inox 18/10 comandato a rubinetto a sfera con leva di azionamento facilmente raggiungibile.

Bacinella estraibile sotto scarico per raccolta residui cottura

Riscaldamento diretto tramite bruciatore tubolare multigas comandato da valvola multifunzione monocomando con pilota, termocoppia, e accensione piezoelettrica

Manopole in materiale atermico.

Piedini in acciaio inox AISI 304 18/10 regolabili in altezza.

Certificazione di conformità CE/IMQ.

#### DATI TECNICI

Larghezza (mm) 800

Profondità (mm) 900

Altezza (mm) 850

Peso (Kg) 70

Volume (m<sup>3</sup>) 0,7

Potenza gas (kW) 15,0

Vasca n. 1 GN 1/1 Capacità 40 lt

# DROP-IN COOKING ELEMENTS



# DROP-IN

## ELEMENTI DROP-IN

DROP-IN ELEMENTS - EINBAUELEMENTE - ELEMENTS ENCASTRABLES -  
ELEMENTOS ENCASTRABLES

	Model	 (A x B x C) mm	kW		€
<b>CUCINE GAS DROP-IN - DROP-IN GAS RANGES - EINGEBAUTER GASHERDE - CUISINIÈRES GAZ ENCASTRABLES - COCINAS GAS ENCASTRABLES</b>					
	DP/KUPG2.1M1G	400x700	 12,0	<div style="display: flex; flex-direction: column; align-items: center;"> <div style="border: 1px solid black; border-radius: 10px; padding: 2px 10px; margin-bottom: 5px;">4,5</div> <div style="border: 1px solid black; border-radius: 10px; padding: 2px 10px;">7,5</div> </div>	1.459,00
	DP/KUPG4.2M2G	800x700	 24,0	<div style="display: grid; grid-template-columns: 1fr 1fr; gap: 5px; align-items: center;"> <div style="border: 1px solid black; border-radius: 10px; padding: 2px 10px;">4,5</div> <div style="border: 1px solid black; border-radius: 10px; padding: 2px 10px;">4,5</div> <div style="border: 1px solid black; border-radius: 10px; padding: 2px 10px;">7,5</div> <div style="border: 1px solid black; border-radius: 10px; padding: 2px 10px;">7,5</div> </div>	2.281,00
<b>FRIGGITRICI GAS DROP-IN - DROP-IN GAS FRYERS - EINGEBAUTEN GAS FRITTEUSEN - FRITEUSES GAZ ENCASTRABLE- FREIDORAS A GAS ENCASTRABLES</b>					
 	DP/FLG1V13	400x700	 11,2	 Cap. Lt. 13	3.182,00
 	DP/FLG1V17	400x700	 16,5	 Cap. Lt. 17	3.579,00
 	DP/FLG2V13	800x700	 22,4	 Cap. Lt. 13+13	5.513,00
 	DP/FLG2V17	800x700	 33,0	 Cap. Lt. 17+17	6.247,00

















Cestelli, coperchio e n.1 vasca raccogli olio in dotazione - Equipped with baskets, lid and n.1 s/s oil draining tank - Inkl. Körbe, Deckel und n.1 Ölauffangbecken aus Edelstahl - Paniers, couvercle et n.1 bac de récupération huile en acier inoxydable inclus - Cestas, la tapa y n.1 barreño recoge aceite en acero inoxidable en dotación

# DROP-IN

## ELEMENTI DROP-IN

DROP-IN ELEMENTS - EINBAUELEMENTE - ELEMENTS ENCASTRABLE -  
ELEMENTOS DROP-IN













	Model	 (A x B x C) mm	kW		€
<b>FRIGGITRICI ELETTRICHE DROP-IN - DROP-IN ELECTRIC FRYERS - EINGEBAUTEN ELEKTRO FRITTEUSEN - FRITEUSES ÉLECTRIQUE ENCASTRABLE- FREIDORAS ELÉCTRICAS DROP-IN</b>					
	DP/FRE1V13	400x610	 12,0 400V3N~ 50/60Hz	 Cap. Lt. 13	2.804,00
	DP/FRE1V17	400x610	 16,5 400V3N~ 50/60Hz	 Cap. Lt. 17	3.004,00
	DP/FRE2V8	400x610	 14,0 400V3N~ 50/60Hz	 Cap. Lt. 8+8	3.691,00
	DP/FRE2V13	800x610	 24,0 400V3N~ 50/60Hz	 Cap. Lt. 13+13	4.513,00
	DP/FRE2V17	800x610	 33,0 400V3N~ 50/60Hz	 Cap. Lt. 17+17	4.634,00
<p>Cestelli, coperchio e n.1 vasca raccogli olio in dotazione - Equipped with baskets, lid and n.1 s/s oil draining tank - Inkl. Körbe, Deckel und n.1 Ölauffangbecken aus Edelstahl - Paniers, couvercle et n.1 bac de récupération huile en acier inoxydable inclus - Cestas, la tapa y n.1 barreño recoge aceite en acero inoxidable en dotación</p>					

**DROP-IN**

# DROP-IN

## ELEMENTI DROP-IN

DROP-IN ELEMENTS - EINBAUELEMENTE - ELEMENTS ENCASTRABLE -  
ELEMENTOS DROP-IN

	Model	 (A x B x C) mm	kW		€
<b>CUOCIPASTA GAS DROP-IN - DROP-IN GAS PASTA COOKERS - EINGEBAUTEN GAS NUDELKOCHER - CUISEUR À PÂTES ENCASTRABLE GAZ - CUECE-PASTAS A GAS DROP-IN</b>					
	DP/KPG1V40	400x700	11,0	 Lt. 28	3.041,00
	DP/KPG2V80	800x700	22,0	  Lt. 28+28	5.077,00
<b>CUOCIPASTA ELETTRICO DROP-IN - DROP-IN ELECTRIC PASTA COOKERS - EINGEBAUTEN ELEKTRO NUDELKOCHER - CUISEUR À PÂTES ELECTRIQUE ENCASTRABLE - CUECE-PASTAS ELÉCTRICAS DROP-IN</b>					
	DP/KPE1V40	400x610	7,0 400V3N~ 50/60Hz	 Lt. 28	3.350,00
	DP/KPE2V80	800x610	14,0 400V3N~ 50/60Hz	  Lt. 28+28	5.575,00
<b>BAGNOMARIA ELETTRICO DROP-IN - DROP-IN ELECTRIC BAINS-MARIE- EINGEBAUTEN ELEKTRO WASSERBÄDER- BAINS-MARIE ÉLECTRIQUE ENCASTRABLE - BAÑOS MARÍA ELÉCTRICO DROP-IN</b>					
	DP/KME1	400x610	1,5 230V~ 50/60Hz	 Lt. 28	1.900,00
	DP/KME2	800x610	3,0 230V~ 50/60Hz	 Lt. 28	2.514,00

DROP-IN

# DROP-IN

## ACCESSORI PER CUOCIPASTA

ACCESSORIES FOR PASTA COOKERS - ZUBEHÖRE FÜR NUDELKOCHER - ACCESSOIRES  
POUR CUISEUR À PÂTES - ACCESORIOS PARA CUECE-PASTAS

	Model	 (A x B x C) mm	Description	€
<b>ACCESSORI- ACCESSORIES- ZUBEHÖRE- ACCESSOIRES- ACCESORIOS</b>				
	<b>SET 700CESA</b> 2 X 21/99900147 2 X 21/99900148	nr.4 x 143x163x215h	nr.4 cestelli inox 1/6 nr.4 s/s baskets 1/6	<b>528,00</b>
	<b>SET 700CESB</b> 2 X 21/99900148 1 X 21/99900000	nr.2 x 143x163x215h + nr.1 x 290x143x215h	nr.2 cestelli inox 1/6 + nr.1 cestello inox 1/3 con un manico nr.2 s/s baskets 1/6 + nr.1 s/s basket 1/3 with one handle	<b>421,00</b>
	<b>SET 700CESC</b> 2 X 21/99900000	nr.2 x 290x143x215h	nr.2 cestelli inox 1/3 con un manico nr.2 s/s baskets 1/3 with one handle	<b>314,00</b>
	<b>SET 700CESD</b> 1 X 21/99900159	nr.1 x 325x290x215h	nr.1 cestello inox 2/3 con due manici nr.1 s/s basket 2/3 with two handles	<b>219,00</b>
	<b>SET 700CESE</b> 2 X 21/99900081	nr.2 x 288x163x215h	nr.2 cestelli inox 1/3 con due manici nr.2 s/s baskets 1/3 with two handles	<b>336,00</b>
	<b>SET 700CESF</b> 1 X 21/99900147 1 X 21/99900148 1 X 21/99900081	nr.2 x 143x163x215h + nr.1 x 288x163x215h	nr.2 cestelli inox 1/6 + nr.1 cestello inox 1/3 con due manici nr.2 s/s baskets 1/6 + nr.1 s/s basket 1/3 with two handles	<b>432,00</b>
	<b>21/99900147</b>	143x163x215h	cestello 1/6 con manico a destra s/s basket 1/6 with right-hand side handle	<b>132,00</b>
	<b>21/99900148</b>	143x163x215h	cestello inox 1/6 con manico a sinistra s/s basket 1/6 with left-hand side handle	<b>132,00</b>
	<b>21/99900000</b>	290x143x215h	cestello inox 1/3 con un manico s/s basket 1/3 with one handle	<b>157,00</b>
	<b>21/99900081</b>	288x163x215h	cestello inox 1/3 con due manici s/s basket 1/3 with two handles	<b>168,00</b>
	<b>23/99600128</b>	380x270	coperchio inox per vasca lt. 28 s/s 304 lid for tank lt. 28	<b>103,00</b>
	<b>21/99900179</b>	d. 145x200h	cestello tondo d. 145 mm - round s/s basket d. 145 mm	<b>136,00</b>
	<b>SET700CESG</b> 4 X 21/99900179	nr. 4 x d. 145x200h	nr. 4 cestelli tondi d. 145 mm - nr. 4 round s/s baskets d. 145 mm	<b>543,00</b>
	<b>23/99909200</b>		supporto cestelli tondi per vasca GN 1/1 - support for round baskets - tank GN 1/1	<b>112,00</b>

DROP-IN

# DROP-IN

## ELEMENTI DROP-IN

DROP-IN ELEMENTS - EINBAUELEMENTE - ELEMENTS ENCASTRABLE -  
ELEMENTOS DROP-IN

	Model	 (A x B x C) mm	kW		€
<b>VAPORIERA DIM SUM ELETTRICA DROP-IN - ELECTRIC DROP-IN DIM SUM STEAMER - EINGEBAUTEN ELEKTRISCHER DIM SUM DAMPFGERÄTER - CUISEUR VAPEUR POUR DIM SUM ELECTRIQUE ENCASTRABLE - VAPORRERA DIM SUM ELÉCTRICA DROP-IN</b>					
	DP/DKE400	400x610	3,5 400V3N~ 50/60Hz	 GN 1/1 Lt.24	3.859,00
	DP/DSE400	400x610	7,0 400V3N~ 50/60Hz	 GN 1/1 Lt.24	3.965,00
	DP/DKE800	800x610	7,0 400V3N~ 50/60Hz	 GN 2/1 Lt.55	5.218,00
	DP/DSE800	800x810	14,0 400V3N~ 50/60Hz	 GN 2/1 Lt.55	5.368,00
Cestelli in bambù in dotazione - Equipped with bamboo containers - Inkl. Bambù Behälter - Bacs bambù compris dans le prix - Recipientes bambù en dotación					
<b>GRIGLIA A PIETRA LAVICA DROP-IN - DROP-IN LAVASTONE GRILL - EINGEBAUTEN LAVASTEIN- GRILL - GRILLES PIERRE VOLCANIQUE ENCASTRABLE - PARRILLAS E PIERRA VOLCANICA DROP- IN</b>					
	DP/BS1	400x610	8,0		2.470,00
	DP/BS2	800x610	16,0		3.594,00

# DROP-IN

## ELEMENTI DROP-IN

DROP-IN ELEMENTS - EINBAUELEMENTE - ELEMENTS ENCASTRABLE -  
ELEMENTOS DROP-IN















	Model	 (A x B x C) mm	kW		€
<b>FRY-TOP GAS DROP-IN - DROP-IN GAS GRIDDLE PLATES - EINGEBAUTEN GAS GRILLPLATTEN - FRY-TOP GAZ ENCASTRABLE - FRY-TOP A GAS DROP-IN</b>					
	DP/KTG1LC *	400x700	6,0	 mm. 400x530	2.662,00
	DP/KTG1RC *	400x700	6,0	 mm. 400x530	2.725,00
	DP/KTG2LC *	800x700	12,0	 mm. 800x530	3.757,00
	DP/KTG2RC *	800x700	12,0	 mm. 800x530	3.888,00
	DP/KTG2MC *	800x700	12,0	 mm. 800x530	3.867,00
<b>FRY-TOP ELETTRICO DROP-IN - DROP-IN ELECTRIC GRIDDLE PLATES - EINGEBAUTEN ELEKTRO GRILLPLATTEN - FRY-TOP ÉLECTRIQUE ENCASTRABLE - FRY-TOP ELÉCTRICOS DROP-IN</b>					
	DP/KTE1LC *	400x610	5,4 400V3N~ 50/60Hz	 mm. 400x530	2.757,00
* Versione con piastra cromata - Chromium plate version - Ausführung mit verchromte Platte - Version chromée - Versión cromada					

**DROP-IN**

# DROP-IN

## ELEMENTI DROP-IN





DROP-IN ELEMENTS - EINBAUELEMENTE - ELEMENTS ENCASTRABLE -  
ELEMENTOS DROP-IN

	Model	 (A x B x C) mm	kW		€
<b>FRY-TOP ELETTRICO DROP-IN - DROP-IN ELECTRIC GRIDDLE PLATES - EINGEBAUTEN ELEKTRO GRILLPLATTEN - FRY-TOP ÉLECTRIQUE ENCASTRABLE - FRY-TOP ELÉCTRICOS DROP-IN</b>					
	DP/KTE1RC *	400x610	5,4  400V3N~ 50/60Hz	 mm. 400x530	2.823,00
	DP/KTE2LC *	800x610	10,8  400V3N~ 50/60Hz	 mm. 800x530	3.889,00
	DP/KTE2RC *	800x610	10,8  400V3N~ 50/60Hz	 mm. 800x530	4.026,00
	DP/KTE2MC *	800x610	10,8  400V3N~ 50/60Hz	 mm. 800x530	4.006,00
* Versione con piastra cromata - Chromium plate version - Ausführung mit verchromte Platte - Version chromée - Versión cromada					





## BOLLITORE DA BANCO PROFESSIONALE PROFESSIONAL TABLE TOP BOILER

	Model	 (A x B x C) mm	kW	Lt.		€
	<b>JUK800</b>	520x366x585h	 3,2  230V~ 50/60 Hz	9,0		<b>2.165,00</b>

Just Cook è un bollitore da banco adatto alla cottura di pasta fresca, secca o surgelata, riso, uova, carni e verdure...

Just Cook compatta e di piccole dimensioni, è ideale per la cottura veloce al bar garantendo la stessa qualità del ristorante.

Just Cook ha in dotazione 4 cestelli e 3 tempi di cottura preimpostati. A fine cottura, sul display appare il numero di posizione del cestello da estrarre, seguito da un segnale acustico.

Tutte le parti a contatto con il cibo sono realizzate in acciaio inox AISI 304.

Just Cook ha in dotazione:

- . Ventola per il riciclo del vapore di cottura
- . Resistenza rotante
- . Interruttore per il carico dell'acqua
- . Vassoio raccolta condensa
- . Fori per supporto cestini

Just Cook is a table top boiler suitable to cook fresh, dry and frozen pasta, rice, eggs, meat and vegetables.

Just Cook is compact and small size. It is ideal for a fast cooking in a bar granting the same restaurant quality.

Just Cook is equipped with 4 baskets and 3 pre set cooking times. After cooking time on the display appears the basket position to be picked up and a buzzer plays.

All the parts in touch with the food have been realized in AISI 304 stainless steel.

Just Cook standard features:

- . Recirculation steam fan
- . Tilttable heating element
- . Water filling on/off switch
- . Condensation tray
- . Baskets holding holes



**ASIA**

**L'UNICA ED ORIGINALE LINEA ETNICA MADE IN ITALY**



**CUSTOMIZED EQUIPMENT**

**MADE IN ITALY**



**Tutta la qualità del Made in Italy**  
Cucine rigorosamente prodotte  
in Italia.

**All the Made in Italy quality**  
Kitchens exclusively produced  
in Italy.

**Die gesamte Qualität des Made  
in Italy.**  
Geräte ausschließlich in Italien  
produziert.

**Toute la qualité du Made in Italy.**  
Cuisines entièrement fabriquées  
en Italie.

**Toda la calidad del Made in Italy.**  
Cocinas fabricadas por completo  
en Italia.

**MOD.CC/... - MOD.EUR/...**



MOD. C - kW 9,5 Ø mm. 175



MOD. T - kW 14,0 Ø mm. 175



MOD. S - kW 21,0 Ø mm. 220



MOD. B - kW 23,0 - Watt 110,0

230V~ /50Hz Ø mm.150



MOD. P - kW 3,0 Ø mm.82



MOD. M - kW 4,5 Ø mm.110



MOD. G - kW 7,5 Ø mm.130



CERCHIO/CC



GRIGLIA/CC



GRIGLIA/EUR



**CUCINE WOK**

WOK STOVES - WOK HERDE - CUISINIÈRES WOK - COCINAS WOK

PRICE LIST 2025

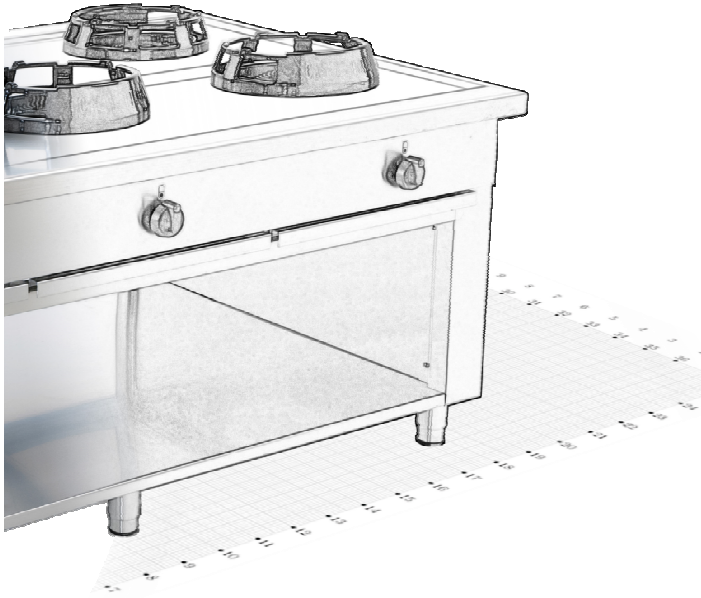

**Progetta la tua cucina su misura.**

Puoi inventare tu la tua cucina ideale.

**Create your own customized kitchen.**

You can create by yourself the kitchen you need.

**Planen Sie Ihr eigene Herd auf Maße.**

Sie können Ihr ideale Herd komplett auf Wunsch realisieren.

**Projetez votre cuisine sur mesure.**

Vous pouvez créer vous-même votre cuisine idéale.

**Proyecta tu cocina a medida.**

Inventa tú mismo tu cocina ideal.

**MOD.CCI/...**

MOD. I - kW 5,0 Ø mm. 300

MOD. H - kW 8,0 Ø mm. 300

MOD. PI - kW 3,5 mm. 360x360

MOD. PH - kW 5,0 mm. 360x360



**WOK**



**CUCINE WOK GAS**

GAS WOK STOVES - WOK GAS HERDE - CUISINIÈRES WOK GAZ -  
COCINAS WOK GAS

WOK

 <b>REALIZZAZIONE SU MISURA</b> CUSTOMIZED KITCHEN - REALISIERUNG NACH MAßE - RÉALISATION SUR MESURE - REALIZACIÓN A MEDIDA						
Model	 (A x B x C) mm	Type	BB 275h	BB 275h €	BA 850h	BA 850h €
CC/01	500x500 <small>minimum dimension for burner C kW 9,5</small>			1.568,00		1.958,00
CC/02	1.000x500			2.705,00		3.212,00
CC/02	500x1.000			2.705,00		3.212,00
CC/03	1.500x500			3.604,00		4.462,00
CC/03	1.000x1.000			3.604,00		4.462,00
CC/04	2.000x500			4.673,00		5.482,00
CC/04	1.000x1.000			4.673,00		5.482,00
CC/05	2.500x500			5.854,00		6.783,00
CC/05	1.500x1.000			5.854,00		6.783,00
CC/06	3.000x500			7.003,00		7.927,00
CC/06	1.500x1.000			7.003,00		7.927,00

**CUCINE WOK GAS**

 GAS WOK STOVES - WOK GAS HERDE - CUISINIÈRES WOK GAZ -  
 COCINAS WOK GAS

<b>REALIZZAZIONE SU MISURA</b> CUSTOMIZED KITCHEN - REALISIERUNG NACH MAßE - RÉALISATION SUR MESURE - REALIZACIÓN A MEDIDA						
Model	 (A x B x C) mm	Type	BB 275h	BB 275h €	BA 850h	BA 850h €
CC/07	2.000x1.000			8.184,00		9.317,00
CC/08	2.000x1.000			9.453,00		10.458,00
CC/09	2.500x1.000			10.636,00		11.742,00
CC/10	2.500x1.000			11.803,00		12.915,00
CC/11	3.000x1.000			13.837,00		14.973,00
CC/12	3.000x1.000			15.506,00		16.665,00

**CUCINE WOK INDUZIONE**

INDUCTION WOK STOVE - WOK INDUKTION HERDE - CUISINIÈRES WOK INDUCTION - COCINAS WOK INDUCCION

	Model	Type	Description	€
	I	5,0 400V3~ 50/60Hz	Wok a induzione mm. 300 Induction wok mm. 300	A RICHIESTA / UPON REQUEST / AUF WUNSCH / SUR DEMANDE / SOBRE PEDIDO
	H	8,0 400V3~ 50/60Hz	Wok a induzione mm. 300 Induction wok mm. 300	
	PI	3,5 400V2~ 50/60Hz	Piastra induzione mm. 360x360 Induction plate mm. 360x360	
	PH	5,0 400V3~ 50/60Hz	Piastra induzione mm. 360x360 Induction plate mm. 360x360	

**CUCINE WOK**

WOK STOVES - WOK HERDE - CUISINIÈRES WOK - COCINAS WOK

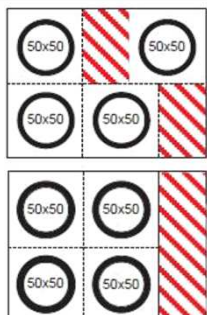
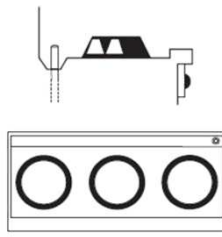
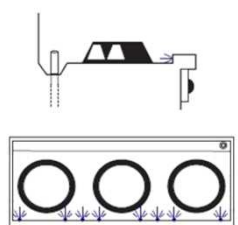
		<b>ACCESSORI</b> ACCESSORIES - ZUBEHÖRE - ACCESSOIRES - ACCESORIOS	
Model	Description		€
<b>FORNO.EL</b> 	Internal dimensions mm.670x430x250h	Forno elettrico ventilato Electric oven Elektro Backofen Four électrique Horno electrico *** nr.3 GN 1/1 - kW 3,7 - 230V~/50Hz ***	<b>4.587,00</b>
<b>PIANO</b> 	Supplemento per piano di lavoro eccedente l' ingombro fisso di mm.500x500 previsto per ogni fuoco Additional cost for surplus top as regard hte fixed space mm.500x500 for every single burner Zuzätzpreis wenn die Fläche grösser ist als mm.500x500 für jeden Brenner Supplement plan de travail pour le plan excédent l'encombrement fixe de mm.500x500 pour chaque feu Suplemento para plano excedente dimension mm.500x500 por cada fuego		<b>620,00</b>  AL METRO QUADRO - FOR SQUARE METER - FÜR QUADRATMETER - AU METRE CARRÉ - POR METRO CUADRADO
<b>KA.MU.POS.</b> 	Canale posteriore con scarico, <b>SENZA</b> sistema di lavaggiodel piano (senza getti d'acqua) - Back water runner with drainage, <b>WITHOUT</b> cleaning system (without watersrays - Hintere Rinne mit Abfluss, <b>OHNE</b> Spühsystem (ohne Wasserdüsen) - Canal de récupération d'eau postérieur avec déchargé <b>SANS</b> jets d'eau - Canal de recuperación de agua trasero con desagüe, <b>SIN</b> chorros de agua  MINIMO € 312,00 / MINIMUM € 312,00 / AM MINDESTE € 312,00 / MINIMUM € 312,00 / MINIMO € 312,00		<b>321,00</b>  AL METRO LINEARE - FOR LINEAR METER - FÜR LINEARMETER - AU METRE LINEAIRE - POR METRO LINEAR
<b>KA.MU.FRO.</b> 	Canale anteriore con scarico, <b>SENZA</b> sistema di lavaggio del piano (senza getti d'acqua) - Frontal water runner with drainage, <b>WITHOUT</b> cleaning system (without watersprays) - Voredere Rinne mit Abfluss, <b>OHNE</b> Spühsystem (ohne Wasserdüsen) - Canal de récupération d'eau frontal avec déchargé <b>SANS</b> jets d'eau - Canal de recuperación de agua frontal con desagüe, <b>SIN</b> chorros de agua  MINIMO € 468,00 / MINIMUM € 468,00 / AM MINDESTE € 468,00 / MINIMUM € 468,00 / MINIMO € 468,00		<b>482,00</b>  AL METRO LINEARE - FOR LINEAR METER - FÜR LINEARMETER - AU METRE LINEAIRE - POR METRO LINEAR
<b>KA.MU.POS.ACQUA</b> 	Canale posteriore con scarico, <b>CON</b> sistema di lavaggiodel piano (con getti d'acqua) - Back water runner with drainage, <b>WITH</b> cleaning system (with watersrays - Hintere Rinne mit Abfluss, <b>MIT</b> Spühsystem (mit Wasserdüsen) - Canal de récupération d'eau postérieur avec déchargé <b>AVEC</b> jets d'eau - Canal de recuperación de agua trasero con desagüe, <b>AVEC</b> chorros de agua  MINIMO € 831,00 / MINIMUM € 831,00 / AM MINDESTE € 831,00 / MINIMUM € 831,00 / MINIMO € 831,00		<b>855,00</b>  AL METRO LINEARE - FOR LINEAR METER - FÜR LINEARMETER - AU METRE LINEAIRE - POR METRO LINEAR

**CUCINE WOK**

WOK STOVES - WOK HERDE - CUISINIÈRES WOK - COCINAS WOK

 <b>ACCESSORI</b> ACCESSORIES - ZUBEHÖRE - ACCESSOIRES - ACCESORIOS		
Model	Description	€
<b>KA.MU.FRO.ACQUA</b> 	Canale anteriore con scarico, <b>CON</b> sistema di lavaggio del piano (con getti d'acqua) - Frontal water runner with drainage, <b>WITH</b> cleaning system (with watersprays) - Voredere Rinne mit Abfluss, <b>MIT</b> Spühsystem (mit Wasserdüsen) - Canal de récupération d'eau frontal avec déchargé <b>AVEC</b> jets d'eau - Canal de recuperación de agua frontal con desagüe, <b>CON</b> chorros de agua	<b>1.062,00</b>  AL METRO LINEARE - FOR LINEAR METER - FÜR LINEARMETER - AU METRE LINEAIRE - POR METRO LINEAR
<b>KA.CE.</b> 	Canale centrale con scarico, <b>SENZA</b> sistema di lavaggio del piano (senza getti d'acqua) - Central water runner with drainage, <b>WITHOUT</b> cleaning system (without watersprays - Zentrale Rinne mit Abfluss, <b>OHNE</b> Spühsystem (ohne Wasserdüsen) - Canal de récupération d'eau central avec déchargé <b>SANS</b> jets d'eau - Canal de recuperación de agua central con desagüe, <b>SIN</b> chorros de agua.	<b>375,00</b>  AL METRO LINEARE - FOR LINEAR METER - FÜR LINEARMETER - AU METRE LINEAIRE - POR METRO LINEAR
<b>KA.CE.ACQUA</b> 	Canale centrale con scarico, <b>CON</b> sistema di lavaggio del piano (con getti d'acqua) - Central water runner with drainage, <b>WITH</b> cleaning system (with watersprays - Zentrale Rinne mit Abfluss, <b>MIT</b> Spühsystem (mit Wasserdüsen) - Canal de récupération d'eau central avec déchargé <b>AVEC</b> jets d'eau - Canal de recuperación de agua central con desagüe, <b>CON</b> chorros de agua.	<b>1.100,00</b>  AL METRO LINEARE - FOR LINEAR METER - FÜR LINEARMETER - AU METRE LINEAIRE - POR METRO LINEAR
<b>APPL.SC.</b> 	Applicazione scarico rettangolare in rete straiabile nel canale Rettangular drainage with removable wirenet basket set into the water runner	<b>741,00</b>
<b>APPL.SC.</b> 	Applicazione scarico tondo sul piano cottura con cesto in rete estraibile per residui con troppo pieno Circular removable wirenet basket set in cooking top with overflow pipe Abfluss mit Körbcheneisennetz heraus ziehbar für Rückst+ Überlauf Decharge avec panier en reseau extractible poue dechtes + trop -plein Desagüe con cesta en malla extraible para residuyos y con reboso	<b>524,00</b>

**CUCINE WOK**



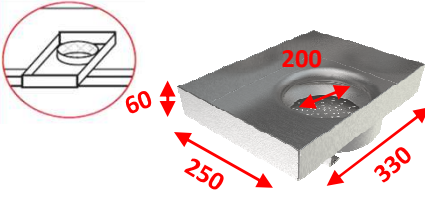
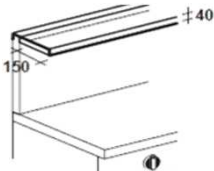
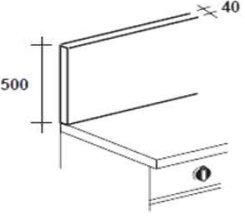
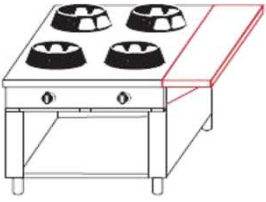
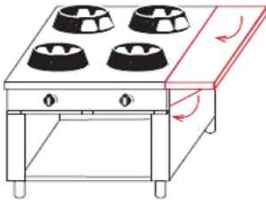

WOK STOVES - WOK HERDE - CUISINIÈRES WOK - COCINAS WOK

**WOK**

		<b>ACCESSORI</b> ACCESSORIES - ZUBEHÖRE - ACCESSOIRES - ACCESORIOS																					
Model	Description	€																					
<b>SIN.EX.</b> 	Applicazione scarico tondo sul piano cottura con sink expander Circular drainage set into cooking top with sink expander Wasser-Abfluss mit herausziehbarem Schmutzsieb Décharge avec panier en réseau extractible pour déchets + trop-plein Desagüe con cesta en malla extractible para residuos y con reboso	<b>663,00</b>																					
<b>MENS.</b> 	Mensola mm.150x40h - Shelf mm.150X40h - Konsole mm.150x40h - Étagère mm.150X40h - Estantería mm.150X40h	<b>257,00</b>																					
	Mensola mm.230x40h - Shelf mm.230X40h - Konsole mm.230x40h - Étagère mm.230X40h - Estantería mm.230X40h	<b>311,00</b>																					
<b>AL METRO LINEARE - FOR LINEAR METER - FÜR LINEARMETER - AU METRE LINEAIRE - POR METRO LINEAR</b>																							
<b>ALZ.SC.</b> 	<table border="1"> <tr> <td><b>40X200H</b></td> <td></td> <td style="text-align: right;"><b>300,00</b></td> </tr> <tr> <td><b>40X300H</b></td> <td>Alzatina posteriore rinforzata</td> <td style="text-align: right;"><b>337,00</b></td> </tr> <tr> <td><b>40X400H</b></td> <td>Reinforced splashback</td> <td style="text-align: right;"><b>380,00</b></td> </tr> <tr> <td><b>40X500H</b></td> <td>Verstärkte Aufkantung</td> <td style="text-align: right;"><b>423,00</b></td> </tr> <tr> <td><b>40X600H</b></td> <td>Dossieret renforcée</td> <td style="text-align: right;"><b>475,00</b></td> </tr> <tr> <td><b>40X700H</b></td> <td>Peto reforzado</td> <td style="text-align: right;"><b>668,00</b></td> </tr> <tr> <td></td> <td>AL METRO LINEARE - FOR LINEAR METER - FÜR LINEARMETER - AU METRE LINEAIRE - POR METRO LINEAR</td> <td style="text-align: right;"><b>668,00</b></td> </tr> </table>	<b>40X200H</b>		<b>300,00</b>	<b>40X300H</b>	Alzatina posteriore rinforzata	<b>337,00</b>	<b>40X400H</b>	Reinforced splashback	<b>380,00</b>	<b>40X500H</b>	Verstärkte Aufkantung	<b>423,00</b>	<b>40X600H</b>	Dossieret renforcée	<b>475,00</b>	<b>40X700H</b>	Peto reforzado	<b>668,00</b>		AL METRO LINEARE - FOR LINEAR METER - FÜR LINEARMETER - AU METRE LINEAIRE - POR METRO LINEAR	<b>668,00</b>	
<b>40X200H</b>		<b>300,00</b>																					
<b>40X300H</b>	Alzatina posteriore rinforzata	<b>337,00</b>																					
<b>40X400H</b>	Reinforced splashback	<b>380,00</b>																					
<b>40X500H</b>	Verstärkte Aufkantung	<b>423,00</b>																					
<b>40X600H</b>	Dossieret renforcée	<b>475,00</b>																					
<b>40X700H</b>	Peto reforzado	<b>668,00</b>																					
	AL METRO LINEARE - FOR LINEAR METER - FÜR LINEARMETER - AU METRE LINEAIRE - POR METRO LINEAR	<b>668,00</b>																					
	<b>MEN.100</b>	<b>400X1.000</b>	<b>401,00</b>																				
	<b>MEN.110</b>	<b>400X1.100</b>	Mensola laterale fissa Fixed side shelf	<b>455,00</b>																			
	<b>MEN.120</b>	<b>400X1.200</b>	Fest seitlichen Konsole Étagère latéral fixé	<b>508,00</b>																			
	<b>MEN.130</b>	<b>400X1.300</b>	Estantería lateral fija	<b>561,00</b>																			
	<b>MEN.140</b>	<b>400X1.400</b>		<b>631,00</b>																			
	<b>MEN./M</b>	<b>...X...</b>	A RICHIESTA / UPON REQUEST / AUF WUNSCH / SUR DEMANDE / SOBRE PEDIDO																				
	<b>MEN.RIB. 100</b>	<b>400X1.000</b>	<b>940,00</b>																				
	<b>MEN.RIB. 110</b>	<b>400X1.100</b>	Mensola laterale a ribalta Side shelf	<b>994,00</b>																			
	<b>MEN.RIB. 120</b>	<b>400X1.200</b>	Seitlichen Konsole Étagère latéral	<b>1.047,00</b>																			
	<b>MEN.RIB. 130</b>	<b>400X1.300</b>	Estantería lateral	<b>1.100,00</b>																			
	<b>MEN.RIB. 140</b>	<b>400X1.400</b>		<b>1.169,00</b>																			
	<b>MEN.RIB. /M</b>	<b>...X...</b>	A RICHIESTA / UPON REQUEST / AUF WUNSCH / SUR DEMANDE / SOBRE PEDIDO																				

**CUCINE WOK**

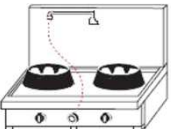
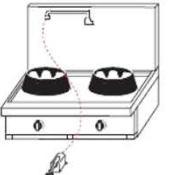
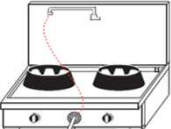
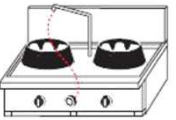
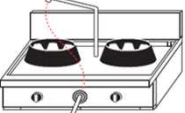
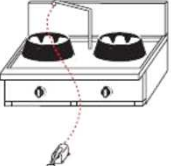



WOK STOVES - WOK HERDE - CUISINIÈRES WOK - COCINAS WOK

		
<b>ACCESSORI</b> ACCESSORIES - ZUBEHÖRE - ACCESSOIRES - ACCESORIOS		
Model	Description	€
<b>RUB.</b> 	Rubinetto acqua mm.300 Water tap mm.300 Wasserhahn mm.300 Robinet pour l'eau mm.300 Grifo de agua mm.300	<b>329,00</b>
<b>RUB.FRONT.</b> 	Rubinetto acqua mm.300 con comando frontale Water tap mm.300 with knob in the front Wasserhahn mm.300 mit Knopf vorne Robinet pour l'eau mm.300 avec poignée frontal Grifo de agua mm.300 con mando frontal	<b>532,00</b>
<b>RUB.PED.</b> 	Rubinetto acqua mm.300 con comando a pedale Water tap mm.300 with pedal control Wasserhahn mm.300 mit Fußpedal Robinet pour l'eau mm.300 avec mitigeur à pédales Grifo de agua mm.300 con mando de pedal	<b>719,00</b>
<b>RUB.GIN.</b> 	Rubinetto acqua mm.300 con comando a ginocchio Water tap mm.300 with knee control Wasserhahn mm.300 mit Knie Bedienung Robinet pour l'eau mm.300 avec mitigeur au genou Grifo de agua mm.300 con mando de rodilla	<b>908,00</b>
<b>MINICO.FRO.</b> 	Mini colonnina con comando frontale Small column with knob in the front Kleine Wassersäule mit Knopf vorne Petite colonne pour l'eau avec poignée frontal Pequeña columna con grifo con mando frontal	<b>547,00</b>
<b>MINICO.GIN.</b> 	Mini colonnina con comando a ginocchio Small column with knee control Kleine Wassersäule mit Knie Bedienung Petite colonne pour l'eau avec poignée au genou Pequeña columna con grifo con mando de rodilla	<b>924,00</b>
<b>MINICO.PED.</b> 	Mini colonnina con comando a pedale Small column with pedal control Kleine Wassersäule mit Fußpedal Petite colonne pour l'eau avec mitigeur à pédales Pequeña columna grifo con mando de pedal	<b>936,00</b>
<b>RUB.ENCORE</b> 	Rubinetto a parete con canna snodabile Encore double deck mount faucet with swivel spout	<b>548,00</b>

**CUCINE WOK**

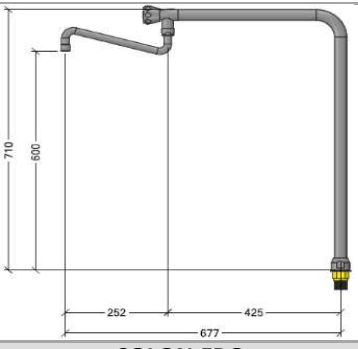
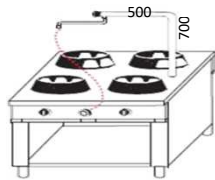
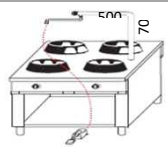
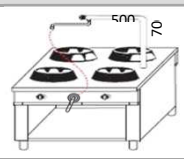
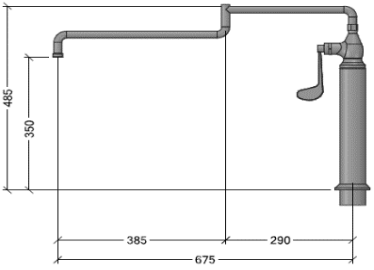



WOK STOVES - WOK HERDE - CUISINIÈRES WOK - COCINAS WOK

**WOK**

 <b>ACCESSORI</b> ACCESSORIES - ZUBEHÖRE - ACCESSOIRES - ACCESORIOS		
Model	Description	€
<b>COLON.</b> 	Colonnina con rubinetto acqua mm.500x700h Water column mm.500x700h Wassersäule mm.500x700h Colonne pour l'eau mm.500x700h Grifo vertical con caño giratorio mm.500x700h	<b>599,00</b>
<b>COLON.FRO.</b> 	Colonnina acqua mm.500x700h con comando frontale Water column mm.500x700h with knob in the front Wassersäule mm.500x700h mit Knopf vorne Colonne pour l'eau mm.500x700h avec poignée frontale Grifo vertical de agua mm.500x700h con mando frontal	<b>798,00</b>
<b>COLON.PED</b> 	Colonnina acqua mm.500x700h con comando a pedale Water column mm.500x700h with pedal control Wassersäule mm.500x700h mit Fußpedal Colonne pour l'eau mm.500x700h avec mitigeur à pédales Grifo vertical de agua mm.500x700h con mando de pedal	<b>962,00</b>
<b>COLON.GIN</b> 	Colonnina acqua mm.500x700h con comando a ginocchio Water column mm.500x700h with knee control Wassersäule mm.500x700h mit Knie Bedienung Colonne pour l'eau mm.500x700h avec mitigeur au gineau Grifo vertical de agua mm.500x700h con mando de rodilla	<b>1.228,00</b>
<b>PILLAR.</b> 	Colonnina orientale doppio snodo Special column faucet - Casta model - double joint one level	<b>945,00</b>
<b>RUB.GIN.</b> 	Comando ginocchio a leva lunga per accessori lavaggio	<b>529,00</b>
<b>RUB.</b> 	Comando a ginocchio manuale per bruciatore a gas	<b>277,00</b>
<b>GIN.GAS</b> 	Comando a ginocchio elettrico per bruciatore a gas	<b>770,00</b>

**CUCINE WOK**

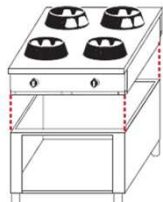
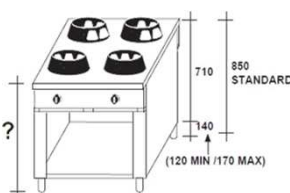

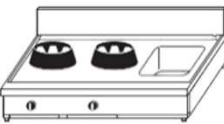
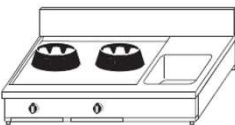
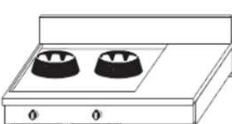

WOK STOVES - WOK HERDE - CUISINIÈRES WOK - COCINAS WOK

 <b>ACCESSORI</b> ACCESSORIES - ZUBEHÖRE - ACCESSOIRES - ACCESORIOS				
Model	Description			€
<b>TRES.</b> 	Trespolo su gambe con piano di fondo Steel stand with bottom shelf Gestell auf Füße mit Grundboden Soubassement ouvert sur pieds Soporte abierto con patas			A RICHIESTA UPON REQUEST AUF WUNSCH SUR DEMANDE SOBRE PEDIDO
<b>BA.SM.</b> 	Base smontabile Removable base Basis getrennt Soubassement démontable Soporte desmontable			A RICHIESTA UPON REQUEST AUF WUNSCH SUR DEMANDE SOBRE PEDIDO
<b>HSP</b> 	Altezza speciale <b>NON</b> compresa tra mm.830 e mm.880 - Special height <b>DIFFERENT</b> from mm.830 to mm.880 - Besondere Hohe <b>NICHT</b> imbegriffen von mm.830 bis mm.880 - Hauteur speciale <b>PAS</b> comprise entre mm.830 et mm.880 - Altura especial <b>NO</b> incluida entre mm.830 y mm.880			<b>720,00</b>
<b>BA.PONTE</b> 	Base a ponte largh.max 1000/2000	NR.PIEDI	2	<b>638,00</b>
	Base a ponte oltre 2100	NR.PIEDI	3	<b>957,00</b>
<b>VASCA</b> 	Applicazione vasca mm.400x400x200h sul piano cucina Sink application mm.400x400x200h on cooking top Anbringung von Becken mm.400x400x200h auf Köchenfläche Application de la cuve mm.400x400x200h sur plan de cuisson Aplicación de la cuba mm.400x400x200h en plano de cocción			<b>1.066,00</b>
<b>VA.RIALZ.</b> 	Applicazione vasca mm.400x400x200h su piano cucina rialzato Sink applicato in mm.400x400x200h on raised cooking top Anbringung von Becken mm.400x400x200h auf erhöht Köchenfläche Application de la cuve mm.400x400x200h sur plan de cuisson relevé Aplicación de la cuba mm.400x400x200h en plano de cocción elevado			<b>1.696,00</b>
<b>PIA.RIALZ.</b> 	Piano cottura rialzato Raised cooking top Erhöht Köchenfläche Plan de cuisson relevé Plano de cocción elevado			<b>620,00</b>

**CUCINE WOK**

WOK STOVES - WOK HERDE - CUISINIÈRES WOK - COCINAS WOK

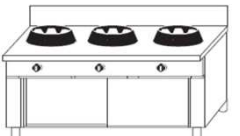
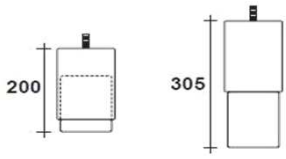
**WOK**

		<b>ACCESSORI</b> ACCESSORIES - ZUBEHÖRE - ACCESSOIRES - ACCESORIOS	
Model	Description	€	
<b>ARM.CAL.</b> 	Armadio caldo kW 2,0 - 230V~ Hot cabinet kW 2,0 - 230V~ Wärmeschrank kW 2,0 - 230V~ Armoire chaud kW 2,0 - 230V~ Armario caliente kW 2,0 - 230V~  <i>INSTALLAZIONE PREVISTA SU ATTREZZATURE SOLO SU BASE CHIUSA / ACCESSORY TO BE ADDED ONLY TO PPLIANCES ON CLOSED BASE / INSTALLATION NUR MIT TÜREN MÖGLICH / INSTALLATION POSSIBLE UNIQUEMENT SUR ARMOIRE FERMÉE / ACCESORIO PARA EQUIPOS SOLO CON BASE CERRADA</i>	<b>1.057,00</b>	
	<b>CH.500</b> Chiusura con portine	<b>229,00</b>	
	<b>CH.600</b> Cupboard closed with doors	<b>265,00</b>	
	<b>CH.700</b> Schrank mit Flügeltüren geschlossen	<b>299,00</b>	
	<b>CH.800</b> Armoire fermé avec portes	<b>349,00</b>	
	<b>CH.900</b> Armario cerrado con puertas	<b>435,00</b>	
	<b>CH.1000</b>	<b>445,00</b>	
	<b>CH.1100</b>	<b>453,00</b>	
	<b>CH.1200</b>	<b>462,00</b>	
	<b>CH.1300</b> Chiusura con porte scorrevoli	<b>470,00</b>	
	<b>CH.1400</b> Cupboard closed with sliding doors	<b>479,00</b>	
	<b>CH.1500</b> Schrank mit Schiebetüren geschlossen	<b>490,00</b>	
	<b>CH.1600</b> Armoire fermé avec portes coulissante	<b>495,00</b>	
	<b>CH.1700</b> Armario cerrado con puertas deslizantes	<b>504,00</b>	
<b>CH.1800</b>	<b>512,00</b>		
<b>CH.1900</b>	<b>522,00</b>		
<b>HPIE</b> 	<b>nr. 4</b> Piedi alti h. 200/305 Tall feet h. 200/305 Pieds hautes h. 200/305 Hoch Füße h. 200/305 Patas altas h. 200/305	<b>348,00</b>	
<b>RUOTA</b> 	Ruota Ø mm.100 Castor Ø mm.100 Rad Ø mm.100 Roue Ø mm.100 Rueda Ø mm.100	CON freno WITH brake	<b>110,00</b>
		SENZA freno WITHOUT brake	<b>94,00</b>
<b>SET4RUOTE</b>	Set di nr.4 ruote (nr.2 con freno e nr.2 senza freno) Set composed in nr.4 whells (nr.2 with breaks and nr.2 without)	<b>408,00</b>	
<b>COP.PIE</b> 	Zoccolo copertura piedi Cover for feet in stainless steel Fußbende für Füße aus Edelstahl Couverture pour les pieds en acier inox Sueco para patas en acero inoxidable	<b>332,00</b>	

 AL METRO LINEARE - FOR LINEAR  
 METER - FÜR LINEARMETER -  
 AU METRE LINEAIRE - POR  
 METRO LINEAR

**CUCINE WOK**



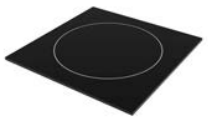

WOK STOVES - WOK HERDE - CUISINIÈRES WOK - COCINAS WOK

		<b>ACCESSORI</b> ACCESSORIES - ZUBEHÖRE - ACCESSOIRES - ACCESORIOS	
Model		Description	€
<b>SUP.GN</b>			
		Supporto con coperchi Support withlids Gestell mit Deckeln Support avec couvercles Soporte con tapas	A RICHIESTA / UPON REQUEST / AUF WUNSCH / SUR DEMANDE / SOBRE PEDIDO
<b>B23</b>			
		Bruciatore radiante infrarossi premiscelato Pre-mixing radiant infra-red burner Infrarotstrahlungs-gemischt Brenner Brûleur radiant infrarouge pré-mélangé Quemador premezclado de radiación infrarroja	<b>1.781,00</b>
		<small>FIAMMA REGOLABILE kW 23,0-kw 18,0 / ADJUSTABLE FLAME kW 23,0-kw 18,0 / EINSTELLBARE FLAMME kW 23,0-kw 18,0 / FLAMME REGLABLE kW 23,0-kw 18,0 / LLAMMA REGULABLE kW 23,0-kw 18,0 - WATT 110,0 - Ac230V/50Hz</small>	
		<b>I</b> Wok a induzione Ø mm.300 Induction wok Ø mm.300	A RICHIESTA / UPON REQUEST / AUF WUNSCH / SUR DEMANDE / SOBRE PEDIDO
		<b>H</b> <small>A SCELTA TRA kW 5,0 E kW 8,0 / UPON REQUEST BETWEEN kW 5,0 AND kW 8,0 / AUF WUNSCH ZWISCHEN kW 5,0 UND kW 8,0 / SUR DEMANDE ENTRE kW 5,0 ET kW 8,0 / SOBRE PEDIDO ENTRE kW 5,0 Y kW 8,0 - 400v3Ac</small>	
		<b>PI</b> Piastra induzione mm.360x360 Induction plate mm. 360x360	A RICHIESTA / UPON REQUEST / AUF WUNSCH / SUR DEMANDE / SOBRE PEDIDO
		<b>PH</b> <small>A SCELTA TRA kW 3,5 E kW 5,0 / UPON REQUEST BETWEEN kW 3,5 AND kW 5,0 / AUF WUNSCH ZWISCHEN kW 3,5 UND kW 5,0 / SUR DEMANDE ENTRE kW 3,5 ET kW 5,0 / SOBRE PEDIDO ENTRE kW 3,5 Y kW 5,0 - 400v2Ac / 400V3Ac</small>	

**CUCINE WOK**

WOK STOVES - WOK HERDE - CUISINIÈRES WOK - COCINAS WOK



**WOK**

		<b>ACCESSORI</b> ACCESSORIES - ZUBEHÖRE - ACCESSOIRES - ACCESORIOS	
Model	Description		€
<b>CER.PER.</b>  	mm.Ø 310x108h	Supporto inox per wok personalizzato Stainless steel wok support Wokaufsatz aus Edelstahl für Wok Support round inox pour wok Soporte redondo inox para wok	<b>422,00</b>
<small>PER BRUCIATORI - FOR BURNERS - FÜR BRENNER - POUR BRÛLEUR - PARA FUEGOS                      C kW 9,5 - T kW 14,0 - S kW 21,0 - B kW 23,0</small>			
<b>CERCHIO/CC</b>  	mm.Ø 380x90h	Cerchio in ghisa smaltata per wok Enameled cast iron wok support Wokaufsatz aus Gußeisen für Wok Support rond en fonte pour wok Soporte redondo para wok	<b>260,00</b>
<small>PER BRUCIATORI - FOR BURNERS - FÜR BRENNER - POUR BRÛLEUR - PARA FUEGOS                      C kW 9,5 - T kW 14,0 - S kW 21,0 - B kW 23,0</small>			
<b>GRIGLIA/CC</b>  	mm.Ø 380x75h	Griglia in ghisa smaltata per padelle Enameled cast iron pan support Rostaufsatz aus Gußeisen für Pfanne Support rond en fonte pour poele Soporte redondo para sartene	<b>245,00</b>
<small>PER BRUCIATORI - FOR BURNERS - FÜR BRENNER - POUR BRÛLEUR - PARA FUEGOS                      C kW 9,5 - T kW 14,0 - S kW 21,0 - B kW 23,0</small>			
<b>GRIGLIA/EUR</b>  	mm.360x300x45h	Griglia in ghisa smaltata per fuochi Eurasia Enameled cast iron support for Eurasia burners Rostaufsatz aus Gußeisen für Eurasia Brenner Support en fonte pour brûleurs Eurasia Soporte para quemadores Eurasia	<b>242,00</b>
<small>PER BRUCIATORI - FOR BURNERS - FÜR BRENNER - POUR BRÛLEUR - PARA FUEGOS                      P kW 3,0 - M kW 4,5 - G kW 7,5</small>			



**CUCINE WOK**

WOK STOVES - WOK HERDE - CUISINIÈRES WOK - COCINAS WOK

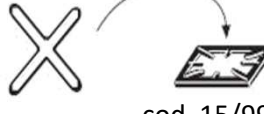
 <b>ACCESSORI</b> <i>ACCESSORIES - ZUBEHÖRE - ACCESSOIRES - ACCESORIOS</i>		
Model	Description	€
<b>RID.CER.</b>  cod. 01/99900007	Riduzione per cerchio CC Reduction grid for CC circle Reduzierrost für Wokaufsatz CC Grille de reduction pour support rond CC Rejilla reductore para soporte CC	<b>72,00</b>
<b>RID.GRI.</b>  cod. 01/99900008	Riduzione per griglia CC Reduction grill for griddle CC Reduzierrost für Rostaufsatz CC Grille de reduction pour support poele CC Rejilla reductora para parrilla CC	<b>62,00</b>
<b>RID.EUR.</b>  cod. 15/99901069	Griglia di riduzione cromata per cucina EURASIA Chromed reduction grid for EURASIA stove Verchromte Reduzierrost für EURASIA Herd Grille de reduction chromée pour support poele EURASIA Rejilla reductore cromada para cocina EURASIA	<b>53,00</b>

**WOK**



**CUCINE WOK**

WOK STOVES - WOK HERDE - CUISINIÈRES WOK - COCINAS WOK



**CUCINE WOK SPECIALI**

SPECIAL WOK STOVES - BESONDERE WOK HERDE - CUISINIÈRES WOK SPÉCIALES - COCINAS WOK ESPECIALES

Series	Model	Code		€
--------	-------	------	---	---



**TB**

**WOK**



cod. CC/03 TB03150050BB

- Modello da banco
- Piano liscio in acciaio AISI 304 18/10 spessore 2,5 mm rinforzato.
- Padella raccogli goccia estraibile sotto i bruciatori.
- Struttura interamente realizzata in acciaio inox AISI304 18/10
- Bruciatori a scelta fra C 9,5 kW - T 14,0 kW - S 21,0 kW – P 3,0 kW – M 4,5 kW – G 7,5 kW.
- Optional bruciatore radiante infrarossi premiscelato B 23,0 kW – Watt 110,0 230 V~ /50Hz
- Model without support
- Cooking top made of stainless steel AISI 304 18/10 (2,5 mm thick), reinforced with welded pipes.
- Removable drip pans.
- Structure made entirely of stainless steel AISI 304 18/10
- Atmospheric burners C 9,5 kW - T 14,0 kW - S 21,0 kW – P 3,0 kW – M 4,5 kW – G 7,5 kW.
- Optional: Pre-mixing radiant infra-red burner "B" 23,0 kW – Watt 110,0 230 V~ /50Hz

	CC/01	TB01060050BB	600	500	275	<b>1.599,00</b>
	CC/01	TB01060060BB	600	600	275	<b>1.636,00</b>
	CC/02	TB02100050BB	1.000	500	275	<b>2.705,00</b>
	CC/02	TB02100060BB	1.000	600	275	<b>2.767,00</b>
	CC/03	TB03150050BB	1.500	500	275	<b>3.604,00</b>
	CC/03	TB03150060BB	1.500	600	275	<b>3.696,00</b>

**CUCINE WOK**

WOK STOVES - WOK HERDE - CUISINIÈRES WOK - COCINAS WOK

**CUCINE WOK SPECIALI**

SPECIAL WOK STOVES - BESONDERE WOK HERDE - CUISINIÈRES WOK SPÉCIALES - COCINAS WOK ESPECIALES

Series	Model	Code	 (A x B x C) mm	€
--------	-------	------	--------------------	---

**TL**

**WOK**

cod. CC/01 TL01060060GG

- Modello da banco con piedi h 280 mm regola bili in altezza, in inox AISI 304 18/10.
- Piano liscio in acciaio AISI 304 18/10 spessore 2,5 mm rinforzato.
- Padella raccogli gocciola estraibile sotto i bruciatori.
- Struttura interamente realizzata in acciaio inox AISI304 18/10
- Bruciatori a scelta fra C 9,5 kW - T 14,0 kW- S 21,0 kW – P 3,0 kW – M 4,5 kW – G 7,5 kW.
- Optional bruciatore radiante infrarossi premiscelato tipo B 23,0 kW – Watt 110,0 230 V~ /50Hz
- Model without support with special feet h 280 mm, in stainless steel AISI 304 18/10
- Cooking top made of stainless steel AISI 304 18/10 (2,5 mm thick), reinforced with welded pipes.
- Removable drip pans.
- Structure made entirely of stainless steel AISI 304 18/10
- Atmospheric burners C 9,5 kW- T 14,0 kW- S 21,0 kW – P 3,0 kW – M 4,5 kW – G 7,5 kW.
- Optional: Pre-mixing radiant infra-red burner "B" 23,0 kW – Watt 110,0 230 V~ /50Hz.

	CC/01	TL01060050GG	600	500	500	<b>1.947,00</b>
	CC/01	TL01060060GG	600	600	500	<b>1.984,00</b>
	CC/02	TL02100050GG	1.000	500	500	<b>3.053,00</b>
	CC/02	TL02100060GG	1.000	600	500	<b>3.114,00</b>
	CC/03	TL03150050GG	1.500	500	500	<b>3.951,00</b>
	CC/03	TL03150060GG	1.500	600	500	<b>4.044,00</b>

**CUCINE WOK**

WOK STOVES - WOK HERDE - CUISINIÈRES WOK - COCINAS WOK

**CUCINE WOK SPECIALI**

SPECIAL WOK STOVES - BESONDERE WOK HERDE - CUISINIÈRES WOK SPÉCIALES - COCINAS WOK ESPECIALES

**LS****Mod. BB****Mod. BA**

BB cod. CC/04 LS03150070BB  
BA cod. CC/04 LS04200070BA

- Modello da banco, e modello su base aperta h 850 mm
- Piano liscio in acciaio AISI 304 18/10 spessore 2,5 mm rinforzato.
- Alzatina h 200 mm.
- Struttura interamente realizzata in acciaio inox AISI304 18/10
- Padella raccogli gocciola estraibile sotto i bruciatori.
- Piedi regola bili in altezza, in inox AISI 304 18/10
- Bruciatori a scelta fra C 9,5 kW - T 14,0 kW- S 21,0 kW – P 3,0 kW – M 4,5 kW – G 7,5 kW.
- Optional bruciatore radiante infrarossi premiscelato tipo B 23,0 kW – Watt 110,0 230 V~ /50Hz

- Model without support or on open stand h 850 mm
- Cooking top made of stainless steel AISI 304 18/10 (2,5 mm thick), reinforced with welded pipes
- Splashback h 200 mm
- Structure made entirely of stainless steel AISI 304 18/10
- Removable drip pans
- Stainless steel AISI 304 18/10 adjustable feet
- Atmospheric burners C 9,5 kW- T 14,0 kW- S 21,0 kW – P 3,0 kW – M 4,5 kW – G 7,5 kW.
- Optional: Pre-mixing radiant infra-red burner "B" 23,0 kW – Watt 110,0 230 V~ /50Hz









**CUCINE WOK**

WOK STOVES - WOK HERDE - CUISINIÈRES WOK - COCINAS WOK

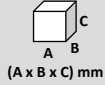

**CUCINE WOK SPECIALI**

SPECIAL WOK STOVES - BESONDERE WOK HERDE - CUISINIÈRES WOK SPÉCIALES - COCINAS WOK ESPECIALES

Series	Model	Code	 (A x B x C) mm			€
	CC/01	LS01060060BB	600	600	275	<b>1.636,00</b>
	CC/01	LS01060070BB	600	700	275	<b>1.674,00</b>
	CC/01	LS01060060BA	600	600	850	<b>2.026,00</b>
	CC/01	LS01060070BA	600	700	850	<b>2.064,00</b>
	CC/02	LS02100060BB	1.000	600	275	<b>2.767,00</b>
	CC/02	LS02100070BB	1.000	700	275	<b>2.830,00</b>
	CC/02	LS02100060BA	1.000	600	850	<b>3.274,00</b>
	CC/02	LS02100070BA	1.000	700	850	<b>3.336,00</b>
	CC/03	LS03150060BB	1.500	600	275	<b>3.696,00</b>
	CC/03	LS03150070BB	1.500	700	275	<b>3.790,00</b>
	CC/03	LS03150060BA	1.500	600	850	<b>4.555,00</b>
	CC/03	LS03150070BA	1.500	700	850	<b>4.648,00</b>
	CC/04	LS04200060BB	2.000	600	275	<b>4.797,00</b>
	CC/04	LS04200070BB	2.000	700	275	<b>4.921,00</b>
	CC/04	LS04200060BA	2.000	600	850	<b>5.606,00</b>
	CC/04	LS04200070BA	2.000	700	850	<b>5.730,00</b>
	CC/05	LS02500060BB	2.500	600	275	<b>6.009,00</b>
	CC/05	LS02500070BB	2.500	700	275	<b>6.164,00</b>
	CC/05	LS02500060BA	2.500	600	850	<b>6.938,00</b>
	CC/05	LS02500070BA	2.500	700	850	<b>7.094,00</b>

**LS**

**WOK**

**CUCINE WOK**

WOK STOVES - WOK HERDE - CUISINIÈRES WOK - COCINAS WOK

**CUCINE WOK SPECIALI****SPECIAL WOK STOVES - BESONDERE WOK HERDE - CUISINIÈRES WOK SPÉCIALES - COCINAS WOK ESPECIALES****KS****WOK**

cod. CC/02 KS02120070BA

Modello da banco, e modello su base aperta h 850 mm

- Piano liscio in acciaio AISI 304 18/10 spessore 2,5 mm rinforzato.
- Piano ribassato con canale posteriore senza sistema di lavaggio
- Alzatina h 200 mm.
- Struttura interamente realizzata in acciaio inox AISI304 18/10
- Padella raccogli gocciola estraibile sotto i bruciatori.
- Piedi regola bili in altezza, in inox AISI 304 18/10
- Bruciatori a scelta fra C 9,5 kW - T 14,0 kW- S 21,0 kW – P 3,0 kW – M 4,5 kW – G 7,5 kW.
- Optional bruciatore radiante infrarossi premiscelato tipo B 23,0 kW – Watt 110,0 230 V~ /50Hz

- Model without support or on open stand h 850 mm
- Cooking top made of stainless steel AISI 304 18/10 (2,5 mm thick), reinforced with welded pipes
- Cooking top with runner without automatic cleaning system (water sprays)
- Splashback h 200 mm
- Structure made entirely of stainless steel AISI 304 18/10
- Removable drip pans.
- Stainless steel AISI 304 18/10 adjustable feet
- Atmospheric burners C 9,5 kW- T 14,0 kW- S 21,0 kW – P 3,0 kW – M 4,5 kW – G 7,5 kW.
- Optional: Pre-mixing radiant infra-red burner "B" 23,0 kW – Watt 110,0 230 V~ /50Hz









**CUCINE WOK**

WOK STOVES - WOK HERDE - CUISINIÈRES WOK - COCINAS WOK

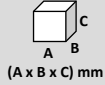

**CUCINE WOK SPECIALI**

SPECIAL WOK STOVES - BESONDERE WOK HERDE - CUISINIÈRES WOK SPÉCIALES - COCINAS WOK ESPECIALES

Series	Model	Code	 (A x B x C) mm			€	
<b>KS</b>		CC/01	KS01060070BB	600	700	315	<b>1.995,00</b>
	CC/01	KS01060070BA	600	700	850	<b>2.384,00</b>	
	CC/02	KS02100070BB	1.000	700	315	<b>3.150,00</b>	
	CC/02	KS02100070BA	1.000	700	850	<b>3.657,00</b>	
	CC/02	KS02120070BB	1.200	700	315	<b>3.300,00</b>	
	CC/02	KS02120070BA	1.200	700	850	<b>3.807,00</b>	
	CC/03	KS03150070BB	1.500	700	315	<b>4.271,00</b>	
	CC/03	KS03150070BA	1.500	700	850	<b>5.129,00</b>	
	CC/03	KS03180070BB	1.800	700	315	<b>4.497,00</b>	
	CC/03	KS03180070BA	1.800	700	850	<b>5.355,00</b>	
	CC/04	KS04200070BB	2.000	700	315	<b>6.076,00</b>	
	CC/04	KS04200070BA	2.000	700	850	<b>6.782,00</b>	
	CC/04	KS04240070BB	2.400	700	315	<b>6.275,00</b>	
	CC/04	KS04240070BA	2.400	700	850	<b>7.084,00</b>	
	CC/05	KS05250070BB	2.500	700	315	<b>7.377,00</b>	
	CC/05	KS05250070BA	2.500	700	850	<b>8.307,00</b>	
	CC/05	KS05300070BB	3.000	700	315	<b>7.755,00</b>	
	CC/05	KS05300070BA	3.000	700	850	<b>8.684,00</b>	

**WOK**

**CUCINE WOK**

WOK STOVES - WOK HERDE - CUISINIÈRES WOK - COCINAS WOK

**CUCINE WOK SPECIALI**

SPECIAL WOK STOVES - BESONDERE WOK HERDE - CUISINIÈRES WOK SPÉCIALES - COCINAS WOK ESPECIALES

**KT****WOK**

cod. CC/04 KT04200070BA

Modello da banco, e modello su base aperta h 850 mm

- Piano liscio in acciaio AISI 304 18/10 spessore 2,5 mm rinforzato.
- Piano ribassato con canale posteriore senza sistema di lavaggio
- Alzatina rinforzata h 400 mm.
- Rubinetto a leva, L 300 mm
- Struttura interamente realizzata in acciaio inox AISI304 18/10
- Padella raccogli gocciola estraibile sotto i bruciatori.
- Piedi regola bili in altezza, in inox AISI 304 18/10
- Bruciatori a scelta fra C 9,5 kW - T 14,0 kW - S 21,0 kW – P 3,0 kW – M 4,5 kW – G 7,5 kW.
- Optional bruciatore radiante infrarossi premiscelato tipo B 23,0 kW – Watt 110,0 230 V~ /50Hz

- Model without support or on open stand h 850 mm
- Cooking top made of stainless steel AISI 304 18/10 (2,5 mm thick), reinforced with welded pipes
- Cooking top with runner without automatic cleaning system (water sprays)
- Reinforced splashback h 400 mm
- Water tap on the splashback L 300 mm
- Structure made entirely of stainless steel AISI 304 18/10
- Removable drip pans.
- Stainless steel AISI 304 18/10 adjustable feet
- Atmospheric burners C 9,5 kW - T 14,0 kW - S 21,0 kW – P 3,0 kW – M 4,5 kW – G 7,5 kW.
- Optional: Pre-mixing radiant infra-red burner "B" 23,0 kW – Watt 110,0 230 V~ /50Hz









**CUCINE WOK**

WOK STOVES - WOK HERDE - CUISINIÈRES WOK - COCINAS WOK

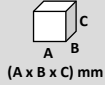

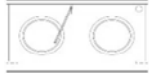
**CUCINE WOK SPECIALI**

SPECIAL WOK STOVES - BESONDERE WOK HERDE - CUISINIÈRES WOK SPÉCIALES - COCINAS WOK ESPECIALES

Series	Model	Code	 (A x B x C) mm			€	
<b>KT</b>		CC/01	KT01060070BB	600	700	315	<b>2.703,00</b>
	CC/01	KT01060070BA	600	700	850	<b>3.093,00</b>	
	CC/02	KT02100070BB	1.000	700	315	<b>3.859,00</b>	
	CC/02	KT02100070BA	1.000	700	850	<b>4.365,00</b>	
	CC/02	KT02120070BB	1.200	700	315	<b>4.085,00</b>	
	CC/02	KT02120070BA	1.200	700	850	<b>4.592,00</b>	
	CC/03	KT03150070BB	1.500	700	315	<b>5.168,00</b>	
	CC/03	KT03150070BA	1.500	700	850	<b>6.027,00</b>	
	CC/03	KT03180070BB	1.800	700	315	<b>5.509,00</b>	
	CC/03	KT03180070BA	1.800	700	850	<b>6.367,00</b>	
	CC/04	KT04200070BB	2.000	700	315	<b>6.979,00</b>	
	CC/04	KT04200070BA	2.000	700	850	<b>8.199,00</b>	
	CC/04	KT04240070BB	2.400	700	315	<b>7.514,00</b>	
	CC/04	KT04240070BA	2.400	700	850	<b>8.323,00</b>	
	CC/05	KT05250070BB	2.500	700	315	<b>8.654,00</b>	
	CC/05	KT05250070BA	2.500	700	850	<b>9.584,00</b>	
	CC/05	KT05300070BB	3.000	700	315	<b>9.222,00</b>	
	CC/05	KT05300070BA	3.000	700	850	<b>10.151,00</b>	

**WOK**

**CUCINE WOK**

WOK STOVES - WOK HERDE - CUISINIÈRES WOK - COCINAS WOK

**CUCINE WOK SPECIALI**

SPECIAL WOK STOVES - BESONDERE WOK HERDE - CUISINIÈRES WOK SPÉCIALES - COCINAS WOK ESPECIALES

**KC**
**WOK**

cod. CC/03 KC03150070BA

Modello da banco, e modello su base aperta h 850 mm

- Piano liscio in acciaio AISI 304 18/10 spessore 2,5 mm rinforzato.
- Piano ribassato con canale posteriore con sistema di lavaggio
- Alzatina h 200 mm.
- Colonnina acqua orientabile dim. 500x700 h mm
- Struttura interamente realizzata in acciaio inox AISI304 18/10
- Padella raccogli gocciola estraibile sotto i bruciatori.
- Piedi regola bili in altezza, in inox AISI 304 18/10
- Bruciatori a scelta fra C 9,5 kW - T 14,0 kW- S 21,0 kW – P 3,0 kW – M 4,5 kW – G 7,5 kW.
- Optional bruciatore radiante infrarossi premiscelato tipo B 23,0 kW – Watt 110,0 230 V~ /50Hz

- Model without support or on open stand h 850 mm
- Cooking top made of stainless steel AISI 304 18/10 (mm. 2,5 thick), reinforced with welded pipes
- Cooking top with runner with automatic cleaning system (water sprays)
- Splashback h 200 mm
- Water coloumn dim. 500x700 h mm
- Structure made entirely of stainless steel AISI 304 18/10
- Removable drip pans.
- Stainless steel AISI 304 18/10 adjustable feet
- Atmospheric burners C 9,5 kW- T 14,0 kW- S 21,0 kW – P 3,0 kW – M 4,5 kW – G 7,5 kW.
- Optional: Pre-mixing radiant infra-red burner "B" 23,0 kW – Watt 110,0 230 V~ /50Hz







**CUCINE WOK**

WOK STOVES - WOK HERDE - CUISINIÈRES WOK - COCINAS WOK

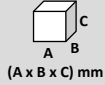

**CUCINE WOK SPECIALI**

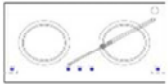
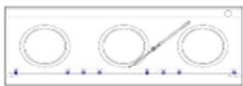
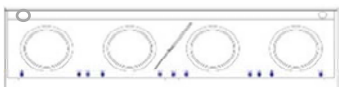
SPECIAL WOK STOVES - BESONDERE WOK HERDE - CUISINIÈRES WOK SPÉCIALES - COCINAS WOK ESPECIALES

Series	Model	Code	 (A x B x C) mm			€	
<b>KC</b>		CC/01	KC01060070BB	600	700	315	<b>3.127,00</b>
		CC/01	KC01060070BA	600	700	850	<b>3.516,00</b>
		CC/02	KC02100070BB	1.000	700	315	<b>4.282,00</b>
		CC/02	KC02100070BA	1.000	700	850	<b>4.789,00</b>
		CC/02	KC02120070BB	1.200	700	315	<b>4.539,00</b>
		CC/02	KC02120070BA	1.200	700	850	<b>5.046,00</b>
		CC/03	KC03150070BB	1.500	700	315	<b>5.669,00</b>
		CC/03	KC03150070BA	1.500	700	850	<b>6.527,00</b>
		CC/03	KC03180070BB	1.800	700	315	<b>6.055,00</b>
		CC/03	KC03180070BA	1.800	700	850	<b>6.914,00</b>
		CC/04	KC04200070BB	2.000	700	315	<b>7.227,00</b>
		CC/04	KC04200070BA	2.000	700	850	<b>8.448,00</b>
		CC/04	KC04240070BB	2.400	700	315	<b>7.742,00</b>
		CC/04	KC04240070BA	2.400	700	850	<b>8.963,00</b>
		CC/05	KC05250070BB	2.500	700	315	<b>9.309,00</b>
		CC/05	KC05250070BA	2.500	700	850	<b>10.238,00</b>
		CC/05	KC05300070BB	3.000	700	315	<b>9.954,00</b>
		CC/05	KC05300070BA	3.000	700	850	<b>10.883,00</b>

**WOK**

**CUCINE WOK**

WOK STOVES - WOK HERDE - CUISINIÈRES WOK - COCINAS WOK

**CUCINE WOK SPECIALI****SPECIAL WOK STOVES - BESONDERE WOK HERDE - CUISINIÈRES WOK SPÉCIALES - COCINAS WOK ESPECIALES****KW****WOK**

cod. CC/03 KW03180070BA

- Modello da banco, e modello su base aperta h 850 mm
- Piano liscio in acciaio AISI 304 18/10 spessore 2,5 mm rinforzato.
- Piano ribassato con canale posteriore con sistema di lavaggio
- Alzatina rinforzata h 400 mm
- Rubinetto a leva, L 300 mm
- Struttura interamente realizzata in acciaio inox AISI304 18/10
- Padella raccogli gocciola estraibile sotto i bruciatori.
- Piedi regola bili in altezza, in inox AISI 304 18/10
- Bruciatori a scelta fra C 9,5 kW - T 14,0 kW- S 21,0 kW – P 3,0 kW – M 4,5 kW – G 7,5 kW.
- Optional bruciatore radiante infrarossi premiscelato tipo B 23,0 kW – Watt 110,0 230 V~ /50Hz

- Model without support or on open stand h 850 mm
- Cooking top made of stainless steel AISI 304 18/10 (2,5 mm thick), reinforced with welded pipes
- Cooking top with runner with automatic cleaning system (water sprays)
- Reinforced splashback h 400 mm
- Water tap on the splashback L 300 mm
- Structure made entirely of stainless steel AISI 304 18/10
- Removable drip pans
- Stainless steel AISI 304 18/10 adjustable feet
- Atmospheric burners C 9,5 kW- T 14,0 kW- S 21,0 kW – P 3,0 kW – M 4,5 kW – G 7,5 kW.
- Optional: Pre-mixing radiant infra-red burner "B" 23,0 kW – Watt 110,0 - Ac230V/50Hz





**CUCINE WOK**

WOK STOVES - WOK HERDE - CUISINIÈRES WOK - COCINAS WOK

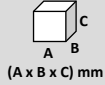

**CUCINE WOK SPECIALI**

SPECIAL WOK STOVES - BESONDERE WOK HERDE - CUISINIÈRES WOK SPÉCIALES - COCINAS WOK ESPECIALES

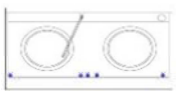
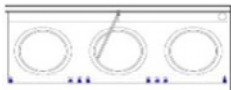
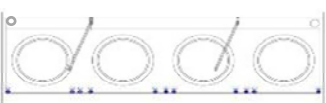
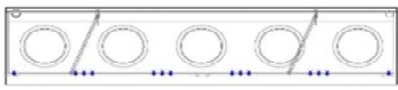
Series	Model	Code	 (A x B x C) mm			€	
<b>KW</b>		CC/01	KW01060070BB	600	700	315	<b>3.236,00</b>
		CC/01	KW01060070BA	600	700	850	<b>3.626,00</b>
		CC/02	KW02100070BB	1.000	700	315	<b>4.932,00</b>
		CC/02	KW02100070BA	1.000	700	850	<b>4.899,00</b>
		CC/02	KW02120070BB	1.200	700	315	<b>4.725,00</b>
		CC/02	KW02120070BA	1.200	700	850	<b>5.232,00</b>
		CC/03	KW03150070BB	1.500	700	315	<b>5.969,00</b>
		CC/03	KW03150070BA	1.500	700	850	<b>6.827,00</b>
		CC/03	KW03180070BB	1.800	700	315	<b>6.470,00</b>
		CC/03	KW03180070BA	1.800	700	850	<b>7.328,00</b>
		CC/04	KW04200070BB	2.000	700	315	<b>8.128,00</b>
		CC/04	KW04200070BA	2.000	700	850	<b>8.937,00</b>
		CC/04	KW04240070BB	2.400	700	315	<b>8.795,00</b>
		CC/04	KW04240070BA	2.400	700	850	<b>9.604,00</b>
		CC/05	KW05250070BB	2.500	700	315	<b>9.989,00</b>
		CC/05	KW05250070BA	2.500	700	850	<b>10.918,00</b>
		CC/05	KW05300070BB	3.000	700	315	<b>10.822,00</b>
		CC/05	KW05300070BA	3.000	700	850	<b>11.752,00</b>

**WOK**

**CUCINE WOK**

WOK STOVES - WOK HERDE - CUISINIÈRES WOK - COCINAS WOK

**CUCINE WOK SPECIALI**

SPECIAL WOK STOVES - BESONDERE WOK HERDE - CUISINIÈRES WOK SPÉCIALES - COCINAS WOK ESPECIALES

**FS****WOK**

cod. CC/05 FS05180090BA

- Modello su base aperta h 780 mm
- Piano liscio in acciaio AISI 304 18/10 spessore 2,5 mm rinforzato.
- Piano ribassato con canale posteriore con sistema di lavaggio
- Retina raccogli residui sullo scarico
- Alzatina rinforzata h 500 mm.
- Rubinetto L.300 mm a leva su alzatina
- Mensola d'appoggio.
- Comando gas a leva per regolazione a ginocchio
- Struttura interamente realizzata in acciaio inox AISI304 18/10 .
- Padella raccogli goccia estraibile sotto i bruciatori.
- Piedini regolabili in altezza in inox AISI 304 18/10
- Bruciatori a scelta fra C 9,5 kW - T 14,0 kW - S 21,0 kW – P 3,0 kW – M 4,5 kW – G 7,5 kW.
- Optional bruciatore radiante infrarossi premiscelato tipo B 23,0 kW – Watt 110,0 230 V~ /50Hz

- Model on open stand h 780 mm
- Cooking top made of stainless steel AISI 304 18/10 (2,5 mm thick), reinforced with welded pipes
- Cooking top with runner with automatic cleaning system (water sprays)
- Wirenet for residues
- Reinforced splashback h 500 mm
- Water tap on the splashback L 300 mm
- Shelf
- Lever Knee control for gas valves
- Structure made entirely of stainless steel AISI 304 18/10
- Removable drip pans.
- Stainless steel AISI 304 18/10 adjustable feet
- Atmospheric burners C 9,5 kW- T 14,0 kW- S 21,0 kW – P 3,0 kW – M 4,5 kW – G 7,5 kW.
- Optional: Pre-mixing radiant infra-red burner "B" 23,0 kW – Watt 110,0 230 V~ /50Hz



**CUCINE WOK**

WOK STOVES - WOK HERDE - CUISINIÈRES WOK - COCINAS WOK



**CUCINE WOK SPECIALI**

SPECIAL WOK STOVES - BESONDERE WOK HERDE - CUISINIÈRES WOK SPÉCIALES - COCINAS WOK ESPECIALES

Series	Model	Code		 (A x B x C) mm	€
--------	-------	------	--	--------------------	---

**FS**

	CC/03	FS03120090BA	1.200	900	780	<b>7.048,00</b>
	CC/04	FS04180090BA	1.800	900	780	<b>9.014,00</b>
	CC/05	FS05180090BA	1.800	900	780	<b>10.161,00</b>
	CC/06	FS06230090BA	2.300	900	780	<b>12.807,00</b>
	CC/07	FS07230090BA	2.300	900	780	<b>13.888,00</b>

**WOK**

**CUCINE WOK**

WOK STOVES - WOK HERDE - CUISINIÈRES WOK - COCINAS WOK

**CUCINE WOK SPECIALI**

SPECIAL WOK STOVES - BESONDERE WOK HERDE - CUISINIÈRES WOK SPÉCIALES - COCINAS WOK ESPECIALES

**EN**
**WOK**

cod. CC/03 EN03150090BA

- Modello su base a ponte h 850 mm
- Piano liscio in acciaio AISI 304 18/10 spessore 2,5 mm rinforzato.
- Piano ribassato con canale posteriore senza sistema di lavaggio
- Retina raccogli residui sullo scarico
- Alzatina rinforzata h 500 mm.
- Rubinetto snodato Encore a leva su alzatina
- Struttura interamente realizzata in acciaio inox AISI304 18/10
- Padella raccogli goccia estraibile sotto i bruciatori
- Bruciatori a scelta fra C 9,5 kW - T 14,0 kW- S 21,0 kW – P 3,0 kW – M 4,5 kW – G 7,5 kW.
- Optional bruciatore radiante infrarossi premiscelato tipo B 23,0 kW – Watt 110,0 230 V~ /50Hz

- Model on bridge stand h 850 mm
- Cooking top made of stainless steel AISI 304 18/10 (2,5 mm thick), reinforced with welded pipes
- Cooking top with runner without automatic cleaning system (water sprays)
- Wirenet for residues
- Reinforced splashback h 500 mm
- Water tap Encore on the splashback
- Structure made entirely of stainless steel AISI 304 18/10
- Removable drip pans.
- Atmospheric burners C 9,5 kW- T 14,0 kW- S 21,0 kW – P 3,0 kW – M 4,5 kW – G 7,5 kW.
- Optional: Pre-mixing radiant infra-red burner "B" 23,0 kW – Watt 110,0 230 V~ /50Hz



**CUCINE WOK**

WOK STOVES - WOK HERDE - CUISINIÈRES WOK - COCINAS WOK



**CUCINE WOK SPECIALI**

SPECIAL WOK STOVES - BESONDERE WOK HERDE - CUISINIÈRES WOK SPÉCIALES - COCINAS WOK ESPECIALES

Series	Model	Code				€
--------	-------	------	--	---	--	---

**EN**

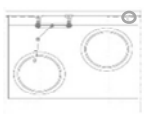
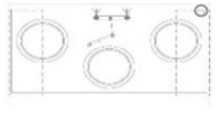
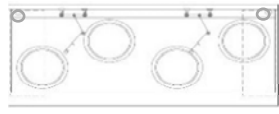
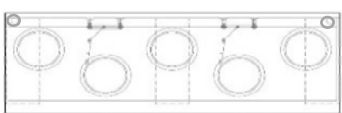
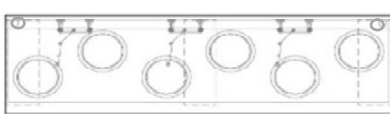
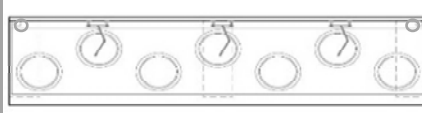
	CC/02	EN02100090BA	1.000	900	850	<b>5.388,00</b>
	CC/03	EN03150090BA	1.500	900	850	<b>7.134,00</b>
	CC/04	EN04200090BA	2.000	900	850	<b>9.608,00</b>
	CC/05	EN05250090BA	2.500	900	850	<b>11.725,00</b>
	CC/06	EN06300090BA	3.000	900	850	<b>13.912,00</b>
	CC/07	EN07350090BA	3.500	900	850	<b>15.643,00</b>

**WOK**

**CUCINE WOK**

WOK STOVES - WOK HERDE - CUISINIÈRES WOK - COCINAS WOK

**CUCINE WOK SPECIALI****SPECIAL WOK STOVES - BESONDERE WOK HERDE - CUISINIÈRES WOK SPÉCIALES - COCINAS WOK ESPECIALES****ES****WOK**

cod. CC/03 ES02100090BA

- Modello su base a ponte h 850 mm
- Piano liscio in acciaio AISI 304 18/10 spessore 2,5 mm rinforzato.
- Piano ribassato con canale posteriore con sistema di lavaggio
- Retina raccogli residui sullo scarico
- Alzatina rinforzata h 500 mm.
- Rubinetto snodato Encore a leva su alzatina
- Struttura interamente realizzata in acciaio inox AISI304 18/10
- Padella raccogli gocciola estraibile sotto i bruciatori
- Bruciatori a scelta fra C 9,5 kW - T 14,0 kW- S 21,0 kW – P 3,0 kW – M 4,5 kW – G 7,5 kW.
- Optional bruciatore radiante infrarossi premiscelato tipo B 23,0 kW – Watt 110,0 230 V~ /50Hz

- Model on bridge stand h 850 mm
- Cooking top made of stainless steel AISI 304 18/10 (2,5 mm thick), reinforced with welded pipes
- Cooking top with runner with automatic cleaning system (water sprays)
- Wirenet for residues
- Reinforced splashback h 500 mm
- Water tap Encore on the splashback
- Structure made entirely of stainless steel AISI 304 18/10
- Removable drip pans.
- Atmospheric burners C 9,5 kW- T 14,0 kW- S 21,0 kW – P 3,0 kW – M 4,5 kW – G 7,5 kW.
- Optional: Pre-mixing radiant infra-red burner "B" 23,0 kW – Watt 110,0 230 V~ /50Hz



**CUCINE WOK**

WOK STOVES - WOK HERDE - CUISINIÈRES WOK - COCINAS WOK



**CUCINE WOK SPECIALI**

SPECIAL WOK STOVES - BESONDERE WOK HERDE - CUISINIÈRES WOK SPÉCIALES - COCINAS WOK ESPECIALES

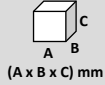
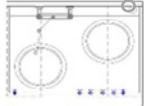
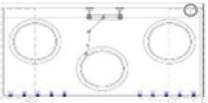
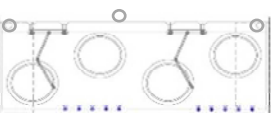
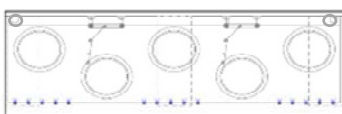
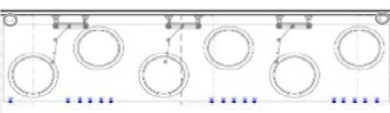
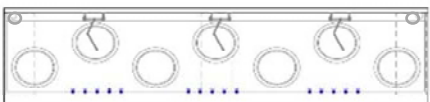
Series	Model	Code		 (A x B x C) mm		€	
<b>ES</b>		CC/02	ES02100090BA	1.000	900	850	<b>5.922,00</b>
		CC/03	ES03150090BA	1.500	900	850	<b>7.935,00</b>
		CC/04	ES04200090BA	2.000	900	850	<b>10.675,00</b>
		CC/05	ES05250090BA	2.500	900	850	<b>13.059,00</b>
		CC/06	ES06300090BA	3.000	900	850	<b>15.513,00</b>
		CC/07	ES07350090BA	3.500	900	850	<b>17.509,00</b>

**WOK**

**CUCINE WOK**

WOK STOVES - WOK HERDE - CUISINIÈRES WOK - COCINAS WOK

**CUCINE WOK SPECIALI**

SPECIAL WOK STOVES - BESONDERE WOK HERDE - CUISINIÈRES WOK SPÉCIALES - COCINAS WOK ESPECIALES

**EG****WOK**

cod. CC/04 EG04200090BA

- Modello su base a ponte h 850 mm
- Piano liscio in acciaio AISI 304 18/10 spessore 2,5 mm rinforzato.
- Piano ribassato con canale posteriore senza sistema di lavaggio
- Retina raccogli residui sullo scarico
- Alzatina h 200 mm
- Colonna acqua pillar faucet Encore, dim. 713x675 h mm
- Struttura interamente realizzata in acciaio inox AISI304 18/10
- Padella raccogli goccia estraibile sotto i bruciatori
- Bruciatori a scelta fra C 9,5 kW - T 14,0 kW- S 21,0 kW – P 3,0 kW – M 4,5 kW – G 7,5 kW.
- Optional bruciatore radiante infrarossi premiscelato tipo B 23,0 kW – Watt 110,0 230 V~ /50Hz

- Model on bridge stand h 850 mm
- Cooking top made of stainless steel AISI 304 18/10 (2,5 mm thick), reinforced with welded pipes
- Cooking top with runner without automatic cleaning system (water sprays)
- Wirenet for residues
- Splashback h 200 mm
- Pillar faucet Encore , dim. 713x675 h mm
- Structure made entirely of stainless steel AISI 304 18/10
- Removable drip pans.
- Atmospheric burners C 9,5 kW- T 14,0 kW- S 21,0 kW – P 3,0 kW – M 4,5 kW – G 7,5 kW.
- Optional: Pre-mixing radiant infra-red burner "B" 23,0 kW – Watt 110,0 230 V~ /50Hz



**CUCINE WOK**

WOK STOVES - WOK HERDE - CUISINIÈRES WOK - COCINAS WOK



**CUCINE WOK SPECIALI**

SPECIAL WOK STOVES - BESONDERE WOK HERDE - CUISINIÈRES WOK SPÉCIALES - COCINAS WOK ESPECIALES

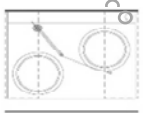
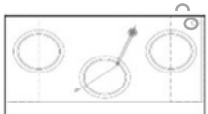
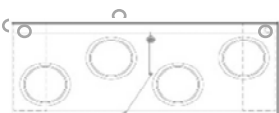
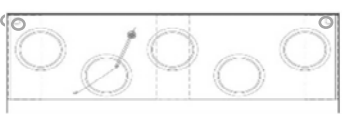
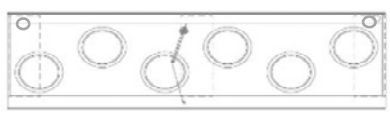
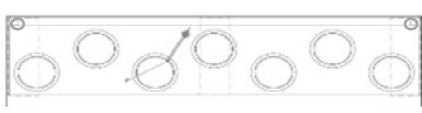
Series	Model	Code					€
<b>EG</b>		CC/02	EG02100090BA	1.000	900	850	<b>5.785,00</b>
		CC/03	EG03150090BA	1.500	900	850	<b>7.304,00</b>
		CC/04	EG04200090BA	2.000	900	850	<b>9.457,00</b>
		CC/05	EG05250090BA	2.500	900	850	<b>11.255,00</b>
		CC/06	EG06300090BA	3.000	900	850	<b>13.213,00</b>
		CC/07	EG07350090BA	3.500	900	850	<b>14.944,00</b>

**WOK**

**CUCINE WOK**

WOK STOVES - WOK HERDE - CUISINIÈRES WOK - COCINAS WOK

**CUCINE WOK SPECIALI****SPECIAL WOK STOVES - BESONDERE WOK HERDE - CUISINIÈRES WOK SPÉCIALES - COCINAS WOK ESPECIALES****ED****WOK**

cod. CC/04 ED04200090BA

- Modello su base a ponte h 850 mm
- Piano liscio in acciaio AISI 304 18/10 spessore 2,5 mm rinforzato.
- Piano ribassato con canale posteriore con sistema di lavaggio
- Retina raccogli residui sullo scarico
- Alzatina h 200 mm
- Colonna acqua pillar faucet Encore , dim. 713x675 h mm
- Struttura interamente realizzata in acciaio inox AISI304 18/10
- Padella raccogli gocciola estraibile sotto i bruciatori
- Bruciatori a scelta fra C 9,5 kW - T 14,0 kW- S 21,0 kW – P 3,0 kW – M 4,5 kW – G 7,5 kW.
- Optional bruciatore radiante infrarossi premiscelato tipo B 23,0 kW – Watt 110,0 230 V~ /50Hz

- Model on bridge stand h 850 mm )
- Cooking top made of stainless steel AISI 304 18/10 (2,5 mm thick), reinforced with welded pipes
- Cooking top with runner with automatic cleaning system (water sprays)
- Wirenet for residues
- Splashback h 200 mm
- Pillar faucet Encore , dim. 713x675 h mm
- Structure made entirely of stainless steel AISI 304 18/10
- Removable drip pans
- Atmospheric burners C 9,5 kW- T 14,0 kW- S 21,0 kW – P 3,0 kW – M 4,5 kW – G 7,5 kW.
- Optional: Pre-mixing radiant infra-red burner "B" 23,0 kW – Watt 110,0 230 V~ /50Hz



**CUCINE WOK**

WOK STOVES - WOK HERDE - CUISINIÈRES WOK - COCINAS WOK



**CUCINE WOK SPECIALI**

SPECIAL WOK STOVES - BESONDERE WOK HERDE - CUISINIÈRES WOK SPÉCIALES - COCINAS WOK ESPECIALES

Series	Model	Code				€	
<b>ED</b>		CC/02	ED02100090BA	1.000	900	850	<b>6.319,00</b>
		CC/03	ED03150090BA	1.500	900	850	<b>8.104,00</b>
		CC/04	ED04200090BA	2.000	900	850	<b>10.524,00</b>
		CC/05	ED05250090BA	2.500	900	850	<b>10.532,00</b>
		CC/06	ED06300090BA	3.000	900	850	<b>14.822,00</b>
		CC/07	ED07350090BA	3.500	900	850	<b>16.810,00</b>

**WOK**

**CUCINE WOK**

WOK STOVES - WOK HERDE - CUISINIÈRES WOK - COCINAS WOK

**CUCINE WOK SPECIALI****SPECIAL WOK STOVES - BESONDERE WOK HERDE - CUISINIÈRES WOK SPÉCIALES - COCINAS WOK ESPECIALES****DS**

cod. CC/06 DS6260085BA

- Modello su base aperta h 700 mm
- Piano liscio in acciaio AISI 304 18/10 spessore 2,5 mm rinforzato.
- Piano ribassato con canale posteriore con sistema di lavaggio
- Comando elettrico a ginocchio per regolazione rubinetto gas
- Scarico nel canale con cestino in lamiera forata dim.230x70x155/285hmm
- Scarico D. 200 mm sul piano con cestello estraibile in rete con sink expander
- Alzatina rinforzata h 350 mm
- Rubinetto snodabile Encore su alzatina.
- Struttura interamente realizzata in acciaio inox AISI304 18/10
- Padella raccogli gocciola estraibile sotto i bruciatori.
- Piedini regolabili in altezza in inox AISI 304 18/10
- Bruciatori a scelta fra C 9,5 kW - T 14,0 kW - S 21,0 kW - P 3,0 kW - M 4,5 kW - G 7,5 kW.
- Optional bruciatore radiante infrarossi premiscelato tipo B 23,0 kW - Watt 110,0 230 V~ /50Hz

- Model on open stand h 700 mm
- Cooking top made of stainless steel AISI 304 18/10 (2,5 mm thick), reinforced with welded pipes
- Cooking top with runner with automatic cleaning system (water sprays)
- Electric lever Knee control for gas valves
- Drainage in the runner with removable wirenet basket dim.230x70x155/285h mm
- Drainage D. 200 mm with removable wirenet basket with sink expander
- Reinforced splashback h 350 mm
- Water tap Encore on the splashback
- Structure made entirely of stainless steel AISI 304 18/10
- Removable drip pans
- Stainless steel AISI 304 18/10 adjustable feet
- Atmospheric burners C 9,5 kW - T 14,0 kW - S 21,0 kW - P 3,0 kW - M 4,5 kW - G 7,5 kW.
- Optional: Pre-mixing radiant infra-red burner "B" 23,0 kW - Watt 110,0 230 V~ /50Hz



**CUCINE WOK**

WOK STOVES - WOK HERDE - CUISINIÈRES WOK - COCINAS WOK



**CUCINE WOK SPECIALI**

SPECIAL WOK STOVES - BESONDERE WOK HERDE - CUISINIÈRES WOK SPÉCIALES - COCINAS WOK ESPECIALES

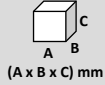
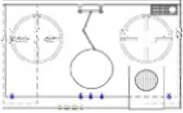
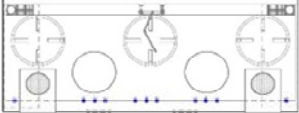
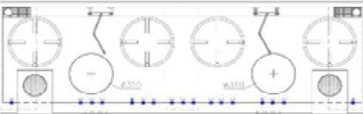
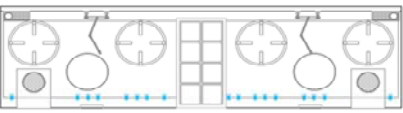
Series	Model	Code		 (A x B x C) mm			€
<b>DS</b>		CC/03	DS03130085BA	1.300	850	700	<b>10.166,00</b>
		CC/05	DS05210085BA	2.100	850	700	<b>16.030,00</b>
		CC/06	DS06260085BA	2.600	850	700	<b>18.617,00</b>
		CC/06	DS06300085BA	3.000	850	700	<b>20.433,00</b>

**WOK**

**CUCINE WOK**

WOK STOVES - WOK HERDE - CUISINIÈRES WOK - COCINAS WOK

**CUCINE WOK SPECIALI****SPECIAL WOK STOVES - BESONDERE WOK HERDE - CUISINIÈRES WOK SPÉCIALES - COCINAS WOK ESPECIALES****CL****WOK**

cod. CC/08 CL08200110BA

- Modello su base aperta h 850 mm
- Modello da centro sala
- Piano liscio in acciaio AISI 304 18/10 spessore 2,5 mm rinforzato.
- Struttura interamente realizzata in acciaio inox AISI304 18/10
- Padella raccogli gocciola estraibile sotto i bruciatori
- Piedi regola bili in altezza, in inox AISI 304 18/10
- Bruciatori a scelta fra C 9,5 kW - T 14,0 kW- S 21,0 kW – P 3,0 kW – M 4,5 kW – G 7,5 kW.
- Optional bruciatore radiante infrarossi premiscelato tipo B 23,0 kW – Watt 110,0 230 V~ /50Hz

- Model on open stand h 850 mm
- Island model
- Cooking top made of stainless steel AISI 304 18/10 (2,5 mm thick), reinforced with welded pipes
- Structure made entirely of stainless steel AISI 304 18/10
- Removable drip pans
- Stainless steel AISI 304 18/10 adjustable feet
- Atmospheric burners C 9,5 kW- T 14,0 kW- S 21,0 kW – P 3,0 kW – M 4,5 kW – G 7,5 kW.
- Optional: Pre-mixing radiant infra-red burner "B" 23,0 kW – Watt 110,0 230 V~ /50Hz



**CUCINE WOK**

WOK STOVES - WOK HERDE - CUISINIÈRES WOK - COCINAS WOK



**CUCINE WOK SPECIALI**

SPECIAL WOK STOVES - BESONDERE WOK HERDE - CUISINIÈRES WOK SPÉCIALES - COCINAS WOK ESPECIALES

Series	Model	Code				€
	CC/04	CL04100110BA	1.000	1100	850	<b>5.543,00</b>
	CC/04	CL04130130BA	1.300	1300	850	<b>5.909,00</b>
	CC/06	CL06150110BA	1.500	1100	850	<b>8.020,00</b>
	CC/06	CL06180120BA	1.800	1200	850	<b>8.337,00</b>
	CC/06	CL06180130BA	1.800	1300	850	<b>8.449,00</b>
	CC/08	CL08200110BA	2.000	1100	850	<b>10.583,00</b>
	CC/08	CL08220120BA	2.200	1200	850	<b>10.855,00</b>
	CC/08	CL08230130BA	2.300	1300	850	<b>11.072,00</b>

**CL**

**WOK**

**CUCINE WOK**

WOK STOVES - WOK HERDE - CUISINIÈRES WOK - COCINAS WOK

**CUCINE WOK SPECIALI****SPECIAL WOK STOVES - BESONDERE WOK HERDE - CUISINIÈRES WOK SPÉCIALES - COCINAS WOK ESPECIALES****CS****WOK**

cod. CC/08 CS06180120BA

- Modello su base aperta h 850 mm
- Modello da centro sala
- Piano liscio in acciaio AISI 304 18/10 spessore 2,5 mm rinforzato.
- Piano con canale centrale senza sistema di lavaggio.
- Retina raccogli residui sullo scarico
- Colonna acqua pillar faucet Encore, dim. 713x675 h mm
- Struttura interamente realizzata in acciaio inox AISI304 18/10
- Padella raccogli gocce estraibile sotto i bruciatori.
- Piedi regola bili in altezza, in inox AISI 304 18/10
- Bruciatori a scelta fra C 9,5 kW - T 14,0 kW- S 21,0 kW – P 3,0 kW – M 4,5 kW – G 7,5 kW.
- Optional: bruciatore radiante infrarossi premiscelato tipo B 23,0 kW – Watt 110,0 230 V~ /50Hz

- Model on open stand h 850 mm
- Island model
- Cooking top made of stainless steel AISI 304 18/10 (2,5 mm thick), reinforced with welded pipes
- Cooking top with runner without automatic cleaning system (water sprays)
- Wirenet for residues
- Pillar faucet Encore , dim. 713x675 h mm
- Structure made entirely of stainless steel AISI 304 18/10
- Removable drip pans
- Stainless steel AISI 304 18/10 adjustable feet
- Atmospheric burners C 9,5 kW- T 14,0 kW- S 21,0 kW – P 3,0 kW – M 4,5 kW – G 7,5 kW.
- Optional: Pre-mixing radiant infra-red burner "B" 23,0 kW – Watt 110,0 230 V~ /50Hz





**CUCINE WOK**

WOK STOVES - WOK HERDE - CUISINIÈRES WOK - COCINAS WOK

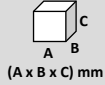

**CUCINE WOK SPECIALI**

SPECIAL WOK STOVES - BESONDERE WOK HERDE - CUISINIÈRES WOK SPÉCIALES - COCINAS WOK ESPECIALES

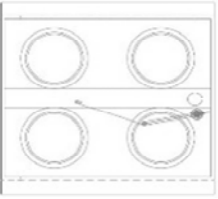
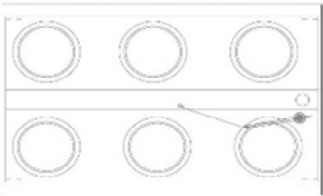
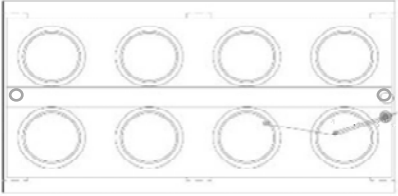
Series	Model	Code	 (A x B x C) mm			€	
		CC/04	CS04100110BA	1.000	1.100	850	<b>6.862,00</b>
		CC/04	CS04120120BA	1.200	1.200	850	<b>7.148,00</b>
		CC/04	CS04130130BA	1.300	1.300	850	<b>7.340,00</b>
		CC/06	CS06150110BA	1.500	1.100	850	<b>9.526,00</b>
		CC/06	CS06180120BA	1.800	1.200	850	<b>9.955,00</b>
		CC/06	CS06180130BA	1.800	1.300	850	<b>10.067,00</b>
		CC/08	CS08200110BA	2.000	1.100	850	<b>12.687,00</b>
		CC/08	CS08220120BA	2.200	1.200	850	<b>13.035,00</b>
		CC/08	CS08230130BA	2.300	1.300	850	<b>13.288,00</b>

WOK

**CUCINE WOK**

WOK STOVES - WOK HERDE - CUISINIÈRES WOK - COCINAS WOK

**CUCINE WOK SPECIALI**

SPECIAL WOK STOVES - BESONDERE WOK HERDE - CUISINIÈRES WOK SPÉCIALES - COCINAS WOK ESPECIALES

**CW**
**WOK**

cod. CC/04 CW04120120BA

- Modello su base aperta h 850 mm
- Modello da centro sala
- Piano liscio in acciaio AISI 304 18/10 spessore 2,5 mm rinforzato.
- Piano con canale centrale con sistema di lavaggio
- Retina raccogli residui sullo scarico.
- Colonna acqua pillar faucet Encore, dim. 713x675 h mm
- Struttura interamente realizzata in acciaio inox AISI304 18/10
- Padella raccogli goccia estraibile sotto i bruciatori
- Piedi regola bili in altezza, in inox AISI 304 18/10
- Bruciatori a scelta fra C 9,5 kW - T 14,0 kW- S 21,0 kW – P 3,0 kW – M 4,5 kW – G 7,5 kW.
- Optional bruciatore radiante infrarossi premiscelato tipo B 23,0 kW – Watt 110,0 230 V~ /50Hz

- Model on open stand h 850 mm
- Island model
- Cooking top made of stainless steel AISI 304 18/10 (2,5 mm thick), reinforced with welded pipes
- Cooking top with runner with automatic cleaning system (water sprays)
- Wirenet for residues
- Pillar faucet Encore , dim. 713x675 h mm
- Structure made entirely of stainless steel AISI 304 18/10
- Removable drip pans
- Stainless steel AISI 304 18/10 adjustable feet
- Atmospheric burners C 9,5 kW- T 14,0 kW- S 21,0 kW – P 3,0 kW – M 4,5 kW – G 7,5 kW.
- Optional: Pre-mixing radiant infra-red burner "B" 23,0 kW – Watt 110,0 230 V~ /50Hz



**CUCINE WOK**

WOK STOVES - WOK HERDE - CUISINIÈRES WOK - COCINAS WOK



**CUCINE WOK SPECIALI**

SPECIAL WOK STOVES - BESONDERE WOK HERDE - CUISINIÈRES WOK SPÉCIALES - COCINAS WOK ESPECIALES

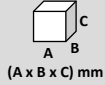
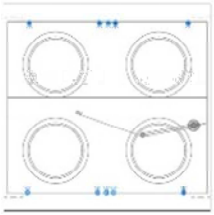
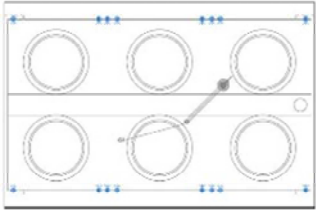
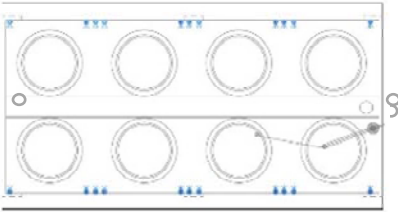
Series	Model	Code				€	
<b>CW</b>		CC/04	CW04100110BA	1.000	1.100	850	<b>7.588,00</b>
		CC/04	CW04120120BA	1.200	1.200	850	<b>8.019,00</b>
		CC/04	CW04130130BA	1.300	1.300	850	<b>8.284,00</b>
		CC/06	CW06150110BA	1.500	1.100	850	<b>10.615,00</b>
		CC/06	CW06180120BA	1.800	1.200	850	<b>11.261,00</b>
		CC/06	CW06180130BA	1.800	1.300	850	<b>11.373,00</b>
		CC/08	CW08200110BA	2.000	1.100	850	<b>14.139,00</b>
		CC/08	CW08220120BA	2.200	1.200	850	<b>14.631,00</b>
		CC/08	CW08230130BA	2.300	1.300	850	<b>14.958,00</b>

**WOK**

**CUCINE WOK**

WOK STOVES - WOK HERDE - CUISINIÈRES WOK - COCINAS WOK

**CUCINE WOK SPECIALI****SPECIAL WOK STOVES - BESONDERE WOK HERDE - CUISINIÈRES WOK SPÉCIALES - COCINAS WOK ESPECIALES****CB****WOK**

cod. CC/06 CB06200140BA

- Modello su base aperta h 850 mm
- Modello da centro sala con comandi in ambo i lati
- Piano liscio in acciaio AISI 304 18/10 spessore 2,5 mm rinforzato.
- Piano con canale centrale con sistema di lavaggio
- Bordo frontale 160 mm
- Scarico nel canale con cestello in lamiera forata dim. 230x70x155/285 h mm
- Scarico D. 200 mm sul piano con cestello estraibile in rete con sink expander
- Colonna acqua pillar faucet Encore, dim. 713x675 h mm.
- Struttura interamente realizzata in acciaio inox AISI304 18/10
- Padella raccogli gocciola estraibile sotto i bruciatori.
- Piedi regola bili in altezza, in inox AISI 304 18/10
- Bruciatori a scelta fra C 9,5 kW - T 14,0 kW - S 21,0 kW - P 3,0 kW - M 4,5 kW - G 7,5 kW.
- Optional: bruciatore radiante infrarossi premiscelato tipo B 23,0 kW - Watt 110,0 230 V~ /50Hz

- Model on open stand h 850 mm
- Island model
- Cooking top made of stainless steel AISI 304 18/10 (2,5 mm thick), reinforced with welded pipes
- Cooking top with runner with automatic cleaning system (water sprays)
- Special front space 160 mm
- Drainage in the runner with removable wirenet basket dim.230x70x155/285 h mm
- Drainage D. 200 mm with removable wirenet basket with sink expander
- Pillar faucet Encore, dim. 713x675 h mm
- Structure made entirely of stainless steel AISI 304 18/10
- Removable drip pans
- Stainless steel AISI 304 18/10 adjustable feet
- Atmospheric burners C 9,5 kW - T 14,0 kW - S 21,0 kW - P 3,0 kW - M 4,5 kW - G 7,5 kW.
- Optional: Pre-mixing radiant infra-red burner "B" 23,0 kW - Watt 110,0 230 V~ /50Hz



**CUCINE WOK**

WOK STOVES - WOK HERDE - CUISINIÈRES WOK - COCINAS WOK



**CUCINE WOK SPECIALI**

SPECIAL WOK STOVES - BESONDERE WOK HERDE - CUISINIÈRES WOK SPÉCIALES - COCINAS WOK ESPECIALES

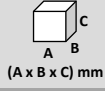
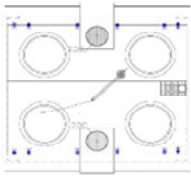
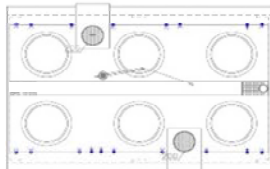
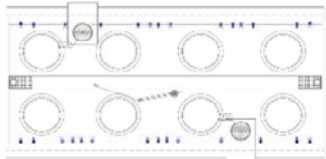
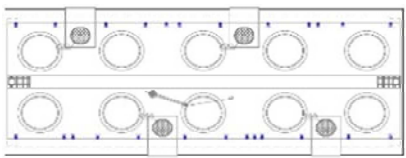
Series	Model	Code				€
<b>CB</b>						
	CC/04	CB04140140BA	1.400	1.400	850	<b>11.633,00</b>
	CC/06	CB06200140BA	2.000	1.400	850	<b>15.460,00</b>
	CC/08	CB08270140BA	2.700	1.400	850	<b>20.223,00</b>
	CC/10	CB10340140BA	3.400	1.400	850	<b>25.576,00</b>

**WOK**

**CUCINE WOK**

WOK STOVES - WOK HERDE - CUISINIÈRES WOK - COCINAS WOK

**CUCINE WOK SPECIALI****SPECIAL WOK STOVES - BESONDERE WOK HERDE - CUISINIÈRES WOK SPÉCIALES - COCINAS WOK ESPECIALES****CM****WOK**

cod. CC/06 CM06180140BA

- Modello su base aperta h 850 mm
- Modello da centro sala con comandi in ambo i lati
- Piano liscio in acciaio AISI 304 18/10 spessore 2,5 mm rinforzato.
- Piano con canale centrale con sistema di lavaggio
- Bordo frontale 160 mm
- Scarico nel canale con cestello in lamiera forata dim. 230x70x155/285 h mm
- Colonna acqua pillar faucet Encore , dim. 713x675 h mm
- Struttura interamente realizzata in acciaio inox AISI304 18/10
- Padella raccogli gocciola estraibile sotto i bruciatori
- Piedi regola bili in altezza, in inox AISI 304 18/10
- Bruciatori a scelta fra C 9,5 kW - T 14,0 kW- S 21,0 kW – P 3,0 kW – M 4,5 kW – G 7,5 kW.
- Optional bruciatore radiante infrarossi premiscelato tipo B 23,0 kW – Watt 110,0 230 V~ /50Hz

- Model on open stand h 850 mm
- Island model
- Cooking top made of stainless steel AISI 304 18/10 (2,5 tmm hick), reinforced with welded pipes
- Cooking top with runner with automatic cleaning system (water sprays)
- Special front space 160 mm
- Drainage in the runner with removable wirenet basket dim.230x70x155/285h mm
- Pillar faucet Encore , dim. 713x675 h mm
- Structure made entirely of stainless steel AISI 304 18/10
- Removable drip pans
- Stainless steel AISI 304 18/10 adjustable feet
- Atmospheric burners C 9,5 kW- T 14,0 kW- S 21,0 kW – P 3,0 kW – M 4,5 kW – G 7,5 kW.
- Optional: Pre-mixing radiant infra-red burner "B" 23,0 kW – Watt 110,0 230 V~ /50Hz



**CUCINE WOK**

WOK STOVES - WOK HERDE - CUISINIÈRES WOK - COCINAS WOK



**CUCINE WOK SPECIALI**

SPECIAL WOK STOVES - BESONDERE WOK HERDE - CUISINIÈRES WOK SPÉCIALES - COCINAS WOK ESPECIALES

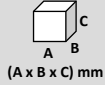
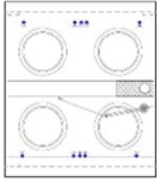
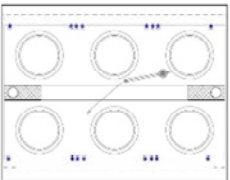
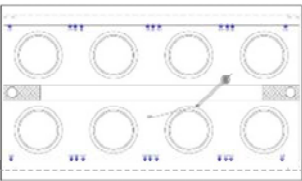
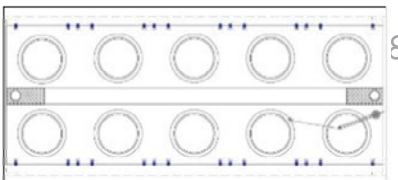
Series	Model	Code				€
<b>CM</b>						
	CC/04	CM04120140BA	1.200	1.400	850	<b>9.772,00</b>
	CC/06	CM06180140BA	1.800	1.400	850	<b>14.260,00</b>
	CC/08	CM08240140BA	2.400	1.400	850	<b>18.093,00</b>
	CC/10	CM10300140BA	3.000	1.400	850	<b>22.141,00</b>

**WOK**

**CUCINE WOK**

WOK STOVES - WOK HERDE - CUISINIÈRES WOK - COCINAS WOK

**CUCINE WOK SPECIALI****SPECIAL WOK STOVES - BESONDERE WOK HERDE - CUISINIÈRES WOK SPÉCIALES - COCINAS WOK ESPECIALES****CT****WOK**

cod. CC/10 CT10300140BA

- Modello su base a ponte h 850 mm
- Modello da centro sala con comandi in ambo i lati
- Piano liscio in acciaio AISI 304 18/10 spessore 2,5 mm rinforzato.
- Piano con canale centrale con sistema di lavaggio
- Bordo frontale 160 mm
- Scarico nel canale con cestello in lamiera forata dim. 230x70x155/285 h mm
- Colonna acqua pillar faucet Encore dim. 713x675 h mm.
- Struttura interamente realizzata in acciaio inox AISI304 18/10
- Padella raccogli goccia estraibile sotto i bruciatori
- Bruciatori a scelta fra C 9,5 kW - T 14,0 kW - S 21,0 kW – P 3,0 kW – M 4,5 kW – G 7,5 kW.
- Optional bruciatore radiante infrarossi premiscelato tipo B 23,0 kW – Watt 110,0 230 V~ /50Hz

- Model on bridge stand h 850 mm
- Island model
- Cooking top made of stainless steel AISI 304 18/10 (2,5 mm thick), reinforced with welded pipes
- Cooking top with runner with automatic cleaning system (water sprays)
- Special front space 160 mm
- Drainage in the runner with removable wirenet basket dim.230x70x155/285 h mm
- Pillar faucet Encore , dim. 713x675 h mm
- Structure made entirely of stainless steel AISI 304 18/10
- Removable drip pans
- Atmospheric burners C 9,5 kW - T 14,0 kW - S 21,0 kW – P 3,0 kW – M 4,5 kW – G 7,5 kW.
- Optional: Pre-mixing radiant infra-red burner "B" 23,0 kW – Watt 110,0 230 V~ /50Hz



**CUCINE WOK**

WOK STOVES - WOK HERDE - CUISINIÈRES WOK - COCINAS WOK



**CUCINE WOK SPECIALI**

SPECIAL WOK STOVES - BESONDERE WOK HERDE - CUISINIÈRES WOK SPÉCIALES - COCINAS WOK ESPECIALES

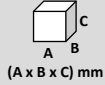
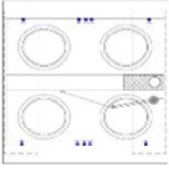
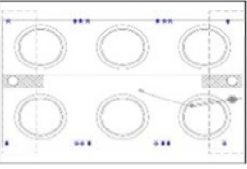
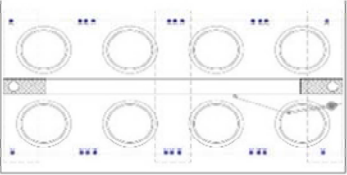
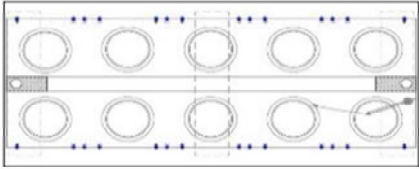
Series	Model	Code				€
<b>CT</b>						
	CC/04	CT04120140BA	1.200	1.400	850	<b>10.553,00</b>
	CC/06	CT06180140BA	1.800	1.400	850	<b>15.041,00</b>
	CC/08	CT08240140BA	2.400	1.400	850	<b>19.265,00</b>
	CC/10	CT10300140BA	3.000	1.400	850	<b>23.312,00</b>

**WOK**



# TEPPANYAKI



# ASIA

L'UNICA ED ORIGINALE LINEA ETNICA **MADE IN ITALY**

**TEPPANYAKI****PIASTRA PER COTTURA GIAPPONESE**JAPANESE HOT PLATE - JAPANISCHE BRATPLATTE - PLAQUE JAPONAIS -  
PLACAS JAPONESAS**CUSTOMIZED EQUIPMENT****MADE IN ITALY****MOD.TEP**

- Cassettino raccolta residui di cottura
- Tray drawer to collect coking residues
- Umfangskanal mit Ablauföffnung und Schublade für Speisereste
- Tiroir de récupération des résidus de cuisson
- Cajón para recogida de los residuos de la cocción

**MOD.TEP**

- Canalina perimetrale con foro di scarico e corrimano
- Perimeter groove with drain and handrail
- Umfangskanal mit Ablauföffnung und Handlauf
- Canal périmétral avec trou et main courante
- Ranura perimetral con orificio de eliminación de los residuos de la cocción y cajón para su recojida.

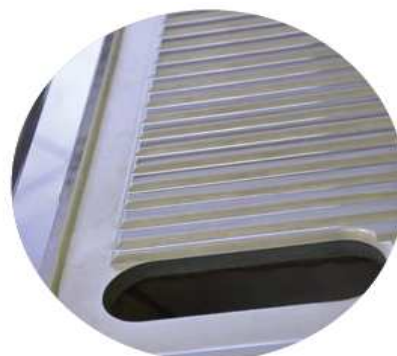
**MOD.TEP-TEB-TER-TEM**

- Piastra di cottura rigata
  - Ribbed plate
  - Gerillte Grillplatte
  - Plaque de cuisson nervurée
  - Placa ranurada
- a richiesta - on request - auf Wunsch  
sur demande - sobre pedido**

**TEPPANYAKI****PIASTRA PER COTTURA GIAPPONESE**JAPANESE HOT PLATE - JAPANISCHE BRATPLATTE - PLAQUE JAPONAIS -  
PLACAS JAPONESAS**MOD.TEB-TER-TEM**

- Cassettino raccolta residui di cottura
- Tray drawer to collect coking residues
- Umfangskanal mit Ablauföffnung und Schublade für Speisereste
- Tiroir de récupération des résidus de cuisson
- Cajón para recogida de los residuos de la cocción

**MOD.TEX**

- Canalina perimetrale con foro di scarico e corrimano
  - Perimeter groove with drain and handrail
  - Umfangskanal mit Ablauföffnung und Handlauf
  - Canal périmétral avec trou et main courante
  - Ranura perimetral con orificio de eliminación de los residuos de la cocción y cajón para su recogida.
- a richiesta - on request - auf Wunsch  
sur demande - sobre pedido**

**MOD.TEB-TER-TEM**

- Piastra di cottura liscia
- Smooth plate
- Ebenmäßige Grillplatte
- Plaque de cuisson lisse
- Placa lisa

**TEPPANYAKI**

**TEPPANYAKI****PIASTRA PER COTTURA GIAPPONESE**JAPANESE HOT PLATE - JAPANISCHE BRATPLATTE - PLAQUE JAPONAIS -  
PLACAS JAPONESAS

Model

kW

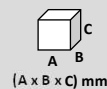

(A x B x C) mm

€

**TEP**

cod. TEP2B/120G

Versione da banco - Bench model - Aufschmodell - Modèle à poser - Modelo de sobremesa

Versione con piastra cromata - Chromium plate version - Ausführung mit Chromplatte - Version avec plaque chromée - Versión con plancha cromada

Model	kW	Width (mm)	Depth (mm)	Height (mm)	Price (€)
	5,8	700	700/760	330	5.443,00
		800	700/760	330	5.534,00
		900	700/760	330	5.624,00
	11,6	1.000	700/760	330	6.620,00
		1.200	700/760	330	6.872,00
		1.400	700/760	330	7.046,00
	17,4	1.200	700/760	330	7.588,00
		1.400	700/760	330	7.780,00
		1.600	700/760	330	7.957,00
	23,2	1.600	700/760	330	8.539,00
		1.800	700/760	330	8.805,00
		2.000	700/760	330	9.073,00
	29,0	2.000	700/760	330	9.744,00
		2.100	700/760	330	9.880,00
		2.200	700/760	330	10.012,00

Accessori in dotazione nr.1 raschietto - Accessories included nr.1 scraper - Zubehöre inbegriffen nr.1 Schaber - Accessories inclusnr.1 raclette - Accesorios incluidos nr.1 rascador

**TEPPANYAKI****PIASTRA PER COTTURA GIAPPONESE**JAPANESE HOT PLATE - JAPANISCHE BRATPLATTE - PLAQUE JAPONAIS -  
PLACAS JAPONESAS





Model	kW	 (A x B x C) mm	€
-------	----	---	---

**TEP**

cod. TEP4/180G

Modello su vano a giorno - Model on open cabinet - Modell mit offenem Unterbau - Modèle sur meuble ouvert - Modelo abierto

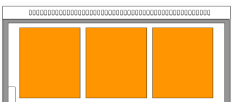
Versione con piastra cromata - Chromium plate version - Ausführung mit Chromplatte - Version avec plaque chromée - Versión con plancha cromada

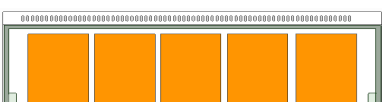
	<b>TEP1/070G</b>	5,8	700	700/760	850	<b>6.109,00</b>
	<b>TEP1/080G</b>		800	700/760	850	<b>6.217,00</b>
	<b>TEP1/090G</b>		900	700/760	850	<b>6.333,00</b>
	<b>TEP2/100G</b>	11,6	1.000	700/760	850	<b>7.296,00</b>
	<b>TEP2/120G</b>		1.200	700/760	850	<b>7.619,00</b>
	<b>TEP2/140G</b>		1.400	700/760	850	<b>7.796,00</b>
	<b>TEP3/120G</b> with only one left hole	17,4	1.200	700/760	850	<b>8.350,00</b>
	<b>TEP3/140G</b>		1.400	700/760	850	<b>8.513,00</b>
	<b>TEP3/160G</b>		1.600	700/760	850	<b>8.697,00</b>
	<b>TEP4/160G</b>	23,2	1.600	700/760	850	<b>9.278,00</b>
	<b>TEP4/180G</b>		1.800	700/760	850	<b>9.541,00</b>
	<b>TEP4/200G</b>		2.000	700/760	850	<b>9.805,00</b>
	<b>TEP5/200G</b>	29,0	2.000	700/760	850	<b>10.553,00</b>
	<b>TEP5/210G</b>		2.100	700/760	850	<b>10.686,00</b>
	<b>TEP5/220G</b>		2.200	700/760	850	<b>10.818,00</b>

Accessori in dotazione nr.1 raschietto - Accessories included nr.1 scraper - Zubehöre inbegriffen nr.1 Schaber - Accessories inclusnr.1 raclette - Accesorios incluidos nr.1 rascador

**TEPPANYAKI**

**TEPPANYAKI****PIASTRA PER COTTURA GIAPPONESE**JAPANESE HOT PLATE - JAPANISCHE BRATPLATTE - PLAQUE JAPONAIS -  
PLACAS JAPONESAS

Model

kW

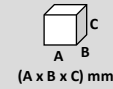

€

**TEB-TER**

cod. TEB4B/160G

Versione da banco - Bench model - Auf Tischmodell - Modèle à poser - Modelo de sobremesa

Piastra conforme a normativa CE 1935/2004-MOCA - Plate in compliance with EC 1935/2004 Regulation-FCM - LKM-Platte konform mit CE 1935/2004 - Plaque en ligne avec le règlement CE 1935/2004-MCDA - Plancha conforme al reglamento CE 1935/2004-MOCA

	<b>TEB1B/070G</b>	5,8	700	700/760	330	<b>5.636,00</b>
	<b>TEB1B/080G</b>		800	700/760	330	<b>5.732,00</b>
	<b>TEB1B/090G</b>		900	700/760	330	<b>5.824,00</b>
	<b>TEB2B/100G</b> with only one left hole	11,6	1.000	700/760	330	<b>6.859,00</b>
	<b>TEB2B/120G</b>		1.200	700/760	330	<b>7.115,00</b>
	<b>TEB2B/140G</b>		1.400	700/760	330	<b>7.297,00</b>
	<b>TEB3B/120G</b> with only one left hole	17,4	1.200	700/760	330	<b>7.856,00</b>
	<b>TEB3B/140G</b>		1.400	700/760	330	<b>8.057,00</b>
	<b>TEB3B/160G</b>		1.600	700/760	330	<b>8.015,00</b>
	<b>TEB4B/160G</b> with only one left hole	23,2	1.600	700/760	330	<b>8.600,00</b>
	<b>TEB4B/180G</b>		1.800	700/760	330	<b>8.870,00</b>
	<b>TER4B/200G</b>		2.000	700/760	330	<b>9.473,00</b>
	<b>TER5B/200G</b> with only one left hole	29,0	2.000	700/760	330	<b>10.175,00</b>
	<b>TER5B/210G</b>		2.100	700/760	330	<b>10.315,00</b>
	<b>TER5B/220G</b>		2.200	700/760	330	<b>10.454,00</b>

Accessori in dotazione nr.1 raschietto - Accessories included nr.1 scraper - Zubehöre inbegriffen nr.1 Schaber - Accessories inclusnr.1 raclette - Accesorios incluidos nr.1 rascador

**TEPPANYAKI****PIASTRA PER COTTURA GIAPPONESE**JAPANESE HOT PLATE - JAPANISCHE BRATPLATTE - PLAQUE JAPONAIS -  
PLACAS JAPONESAS**TEB-TER**

cod. TEB3/120G

Modello su vano a giorno - Model on open cabinet - Modell mit offenem Unterbau - Modèle sur meuble ouvert - Modelo abierto

Piastra conforme a normativa CE 1935/2004-MOCA - Plate in compliance with EC 1935/2004 Regulation-FCM - LKM-Platte konform mit CE 1935/2004 - Plaque en ligne avec le règlement CE 1935/2004-MCDA - Plancha conforme al reglamento CE 1935/2004-MOCA

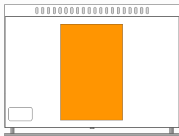
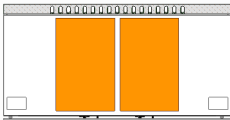
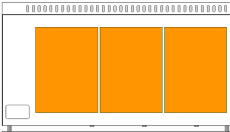
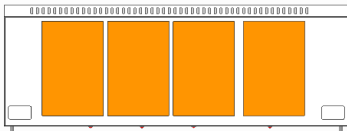
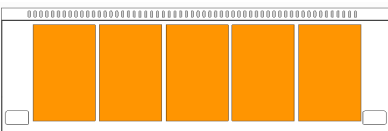
	Model	kW	 (A x B x C) mm			€
	<b>TEB1/070G</b>	5,8	700	700/760	850	<b>6.325,00</b>
	<b>TEB1/080G</b>		800	700/760	850	<b>6.438,00</b>
	<b>TEB1/090G</b>		900	700/760	850	<b>6.557,00</b>
	<b>TEB2/100G</b> with only one left hole	11,6	1.000	700/760	850	<b>7.555,00</b>
	<b>TEB2/120G</b>		1.200	700/760	850	<b>7.890,00</b>
	<b>TEB2/140G</b>		1.400	700/760	850	<b>8.071,00</b>
	<b>TEB3/120G</b> with only one left hole	17,4	1.200	700/760	850	<b>8.646,00</b>
	<b>TEB3/140G</b>		1.400	700/760	850	<b>8.817,00</b>
	<b>TEB3/160G</b>		1.600	700/760	850	<b>9.006,00</b>
	<b>TEB4/160G</b> with only one left hole	23,2	1.600	700/760	850	<b>9.608,00</b>
	<b>TEB4/180G</b>		1.800	700/760	850	<b>9.882,00</b>
	<b>TER4/200G</b>		2.000	700/760	850	<b>10.524,00</b>
	<b>TER5/200G</b> with only one left hole	29,0	2.000	700/760	850	<b>11.328,00</b>
	<b>TER5/210G</b>		2.100	700/760	850	<b>11.472,00</b>
	<b>TER5/220G</b>		2.200	700/760	850	<b>11.612,00</b>

Accessori in dotazione nr.1 raschietto - Accessories included nr.1 scraper - Zubehöre inbegriffen nr.1 Schaber - Accessories inclusnr.1 raclette - Accesorios incluidos nr.1 rascador

**TEPPANYAKI**

**TEPPANYAKI****PIASTRA PER COTTURA GIAPPONESE**JAPANESE HOT PLATE - JAPANISCHE BRATPLATTE - PLAQUE JAPONAIS -  
PLACAS JAPONESAS

Model

kW

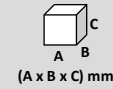

(A x B x C) mm

€

**TEM**

cod. TEM3B/160G

Versione da banco - Bench model - Auftischmodell - Modèle à poser - Modelo de sobremesa

Versione con piastra cromata - Chromium plate version - Ausführung mit Chromplatte - Version avec plaque chromée - Versión con plancha cromada

	Model	kW	A	B	C	€
	TEM1B/070G	5,8	700	700/760	330	5.552,00
	TEM1B/080G		800	700/760	330	5.644,00
	TEM1B/090G		900	700/760	330	5.737,00
	TEM2B/100G with only one left hole	11,6	1.000	700/760	330	6.752,00
	TEM2B/120G		1.200	700/760	330	7.009,00
	TEM2B/140G		1.400	700/760	330	7.187,00
	TEM3B/120G with only one left hole	17,4	1.200	700/760	330	7.738,00
	TEM3B/140G		1.400	700/760	330	7.936,00
	TEM3B/160G		1.600	700/760	330	8.117,00
	TEM4B/160G with only one left hole	23,2	1.600	700/760	330	8.709,00
	TEM4B/180G		1.800	700/760	330	8.982,00
	TEM4B/200G		2.000	700/760	330	9.254,00
	TEM5B/200G with only one left hole	29,0	2.000	700/760	330	9.940,00
	TEM5B/210G		2.100	700/760	330	10.076,00
	TEM5B/220G		2.200	700/760	330	10.211,00

Accessori in dotazione nr.1 raschietto - Accessories included nr.1 scraper - Zubehöre inbegriffen nr.1 Schaber - Accessories inclus nr.1 raclette - Accesorios incluidos nr.1 rascador

**TEPPANYAKI****PIASTRA PER COTTURA GIAPPONESE**JAPANESE HOT PLATE - JAPANISCHE BRATPLATTE - PLAQUE JAPONAIS -  
PLACAS JAPONESAS









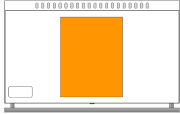

Model	kW	 (A x B x C) mm	€
-------	----	---	---

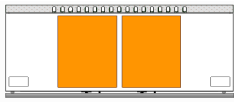
**TEM**

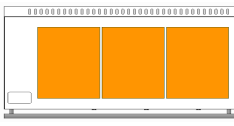
cod. TEM4/180G

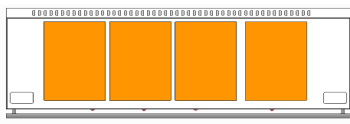
Modello su vano a giorno - Model on open cabinet - Modell mit offenem Unterbau - Modèle sur meuble ouvert - Modelo abierto

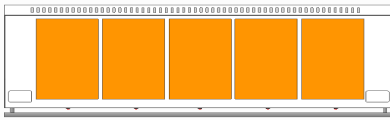
Versione con piastra cromata - Chromium plate version - Ausführung mit Chromplatte - Version avec plaque chromée - Versión con plancha cromada

	<b>TEM1/070G</b>	 5,8	700	700/760	850	<b>6.049,00</b>
	<b>TEM1/080G</b>		800	700/760	850	<b>6.156,00</b>
	<b>TEM1/090G</b>		900	700/760	850	<b>6.271,00</b>
	<b>TEM2/100G</b> with only one left hole	 11,6	1.000	700/760	850	<b>7.225,00</b>
	<b>TEM2/120G</b>		1.200	700/760	850	<b>7.545,00</b>
	<b>TEM2/140G</b>		1.400	700/760	850	<b>7.717,00</b>
	<b>TEM3/120G</b> with only one left hole	 17,4	1.200	700/760	850	<b>8.268,00</b>
	<b>TEM3/140G</b>		1.400	700/760	850	<b>8.430,00</b>
	<b>TEM3/160G</b>		1.600	700/760	850	<b>8.612,00</b>
	<b>TEM4/160G</b> with only one left hole	 23,2	1.600	700/760	850	<b>9.190,00</b>
	<b>TEM4/180G</b>		1.800	700/760	850	<b>9.449,00</b>
	<b>TEM4/200G</b>		2.000	700/760	850	<b>9.709,00</b>
	<b>TEM5/200G</b> with only one left hole	 29,0	2.000	700/760	850	<b>10.450,00</b>
	<b>TEM5/210G</b>		2.100	700/760	850	<b>10.581,00</b>
	<b>TEM5/220G</b>		2.200	700/760	850	<b>10.711,00</b>

Accessori in dotazione nr.1 raschietto - Accessories included nr.1 scraper - Zubehör e inbegriffen nr.1 Schaber - Accessories inclusnr.1 raclette - Accesorios incluidos nr.1 rascador

**TEPPANYAKI**

**TEPPANYAKI****PIASTRA PER COTTURA GIAPPONESE**JAPANESE HOT PLATE - JAPANISCHE BRATPLATTE - PLAQUE JAPONAIS -  
PLACAS JAPONESAS

Model

kW

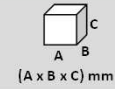

€

**TEP**

cod. TEP4B/160E

Versione da banco - Bench model - Auf Tischmodell - Modèle à poser - Modelo de sobremesa

Versione con piastra cromata - Chromium plate version - Ausführung mit Chromplatte - Version avec plaque chromée - Versión con plancha cromada

Model	kW	Dimensions (mm)	Price (€)
	5,4 400V3N~ 50/60Hz	TEP1B/070E 700 x 700/760 x 330	5.443,00
		TEP1B/080E 800 x 700/760 x 330	5.534,00
		TEP1B/090E 900 x 700/760 x 330	5.624,00
	10,8 400V3N~ 50/60Hz	TEP2B/100E 1.000 x 700/760 x 330	7.704,00
		TEP2B/120E 1.200 x 700/760 x 330	7.957,00
		TEP2B/140E 1.400 x 700/760 x 330	8.339,00
	16,2 400V3N~ 50/60Hz	TEP3B/120E 1.200 x 700/760 x 330	9.906,00
		TEP3B/140E 1.400 x 700/760 x 330	10.230,00
		TEP3B/160E 1.600 x 700/760 x 330	10.553,00
	21,6 400V3N~ 50/60Hz	TEP4B/160E 1.600 x 700/760 x 330	12.491,00
		TEP4B/180E 1.800 x 700/760 x 330	12.798,00
		TEP4B/200E 2.000 x 700/760 x 330	13.120,00
	27,0 400V3N~ 50/60Hz	TEP5B/200E 2.000 x 700/760 x 330	14.853,00
		TEP5B/210E 2.100 x 700/760 x 330	15.013,00
		TEP5B/220E 2.200 x 700/760 x 330	15.174,00

Accessori in dotazione nr.1 raschietto - Accessories included nr.1 scraper - Zubehöre inbegriffen nr.1 Schaber - Accessories inclus nr.1 raclette - Accesorios incluidos nr.1 rascador

# TEPPANYAKI

## PIASTRA PER COTTURA GIAPPONESE

JAPANESE HOT PLATE - JAPANISCHE BRATPLATTE - PLAQUE JAPONAIS -  
PLACAS JAPONESAS



Model	kW	 (A x B x C) mm	€
-------	----	---	---



**TEP**



cod. TEP2/120E

Modello su vano a giorno - Model on open cabinet - Modell mit offenem Unterbau - Modèle sur meuble ouvert - Modelo abierto

Versione con piastra cromata - Chromium plate version - Ausführung mit Chromplatte - Version avec plaque chromée - Versión con plancha cromada

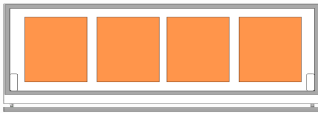
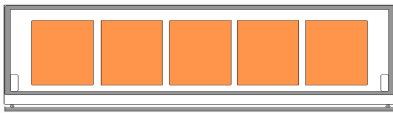
	TEP1/070E	5,4 ⚡ 400V3N~ 50/60Hz	700	700/760	850	6.096,00
	TEP1/080E		800	700/760	850	6.204,00
	TEP1/090E		900	700/760	850	6.312,00
	TEP2/100E	10,8 ⚡ 400V3N~ 50/60Hz	1.000	700/760	850	8.451,00
	TEP2/120E		1.200	700/760	850	8.705,00
	TEP2/140E		1.400	700/760	850	9.028,00
	TEP3/120E	16,2 ⚡ 400V3N~ 50/60Hz	1.200	700/760	850	10.920,00
	TEP3/140E		1.400	700/760	850	11.124,00
	TEP3/160E		1.600	700/760	850	11.420,00
	TEP4/160E	21,6 ⚡ 400V3N~ 50/60Hz	1.600	700/760	850	13.169,00
	TEP4/180E		1.800	700/760	850	13.512,00
	TEP4/200E		2.000	700/760	850	13.913,00
	TEP5/200E	27,0 ⚡ 400V3N~ 50/60Hz	2.000	700/760	850	15.643,00
	TEP5/210E		2.100	700/760	850	15.805,00
	TEP5/220E		2.200	700/760	850	15.967,00

Accessori in dotazione nr.1 raschietto - Accessories included nr.1 scraper - Zubehöre inbegriffen nr.1 Schaber - Accessories inclus nr.1 raclette - Accesorios incluidos nr.1 rascador

TEPPANYAKI

**TEPPANYAKI****PIASTRA PER COTTURA GIAPPONESE**JAPANESE HOT PLATE - JAPANISCHE BRATPLATTE - PLAQUE JAPONAIS -  
PLACAS JAPONESAS

Model

kW

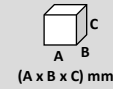

(A x B x C) mm

€

**TEB-TER**

cod. TEB2B/100E

Versione da banco - Bench model - Auf Tischmodell - Modèle à poser - Modelo de sobremesa

Piastra conforme a normativa CE 1935/2004-MOCA - Plate in compliance with EC 1935/2004 Regulation-FCM - LKM-Platte konform mit CE 1935/2004 - Plaque en ligne avec le règlement CE 1935/2004-MCDA - Plancha conforme al reglamento CE 1935/2004-MOCA

	<b>TEB1B/070E</b>	5,4 400V3N~ 50/60Hz	700	700/760	330	<b>5.636,00</b>
	<b>TEB1B/080E</b>		800	700/760	330	<b>5.732,00</b>
	<b>TEB1B/090E</b>		900	700/760	330	<b>5.824,00</b>
	<b>TEB2B/100E</b> with only one left hole	10,8 400V3N~ 50/60Hz	1.000	700/760	330	<b>7.979,00</b>
	<b>TEB2B/120E</b>		1.200	700/760	330	<b>8.240,00</b>
	<b>TEB2B/140E</b>		1.400	700/760	330	<b>8.635,00</b>
	<b>TEB3B/120E</b> with only one left hole	16,2 400V3N~ 50/60Hz	1.200	700/760	330	<b>10.260,00</b>
	<b>TEB3B/140E</b>		1.400	700/760	330	<b>10.593,00</b>
	<b>TEB3B/160E</b>		1.600	700/760	330	<b>10.927,00</b>
	<b>TEB4B/160E</b> with only one left hole	21,6 400V3N~ 50/60Hz	1.600	700/760	330	<b>12.934,00</b>
	<b>TEB4B/180E</b>		1.800	700/760	330	<b>13.253,00</b>
	<b>TER4B/200E</b>		2.000	700/760	330	<b>14.085,00</b>
	<b>TER5B/200E</b> with only one left hole	27,0 400V3N~ 50/60Hz	2.000	700/760	330	<b>15.943,00</b>
	<b>TER5B/210E</b>		2.100	700/760	330	<b>16.114,00</b>
	<b>TER5B/220E</b>		2.200	700/760	330	<b>16.289,00</b>

Accessori in dotazione nr.1 raschietto - Accessories included nr.1 scraper - Zubehöre inbegriffen nr.1 Schaber - Accessories inclusnr.1 raclette - Accesorios incluidos nr.1 rascador

**TEPPANYAKI****PIASTRA PER COTTURA GIAPPONESE**JAPANESE HOT PLATE - JAPANISCHE BRATPLATTE - PLAQUE JAPONAIS -  
PLACAS JAPONESAS**TEB-TER**





Model	kW	 (A x B x C) mm	€
-------	----	---	---



cod. TEB3/120E

Modello su vano a giorno - Model on open cabinet - Modell mit offenem Unterbau - Modèle sur meuble ouvert - Modelo abierto

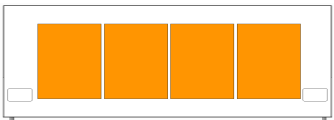
Piastra conforme a normativa CE 1935/2004-MOCA - Plate in compliance with EC 1935/2004 Regulation-FCM - LKM-Platte konform mit CE 1935/2004 - Plaque en ligne avec le règlement CE 1935/2004-MCDA - Plancha conforme al reglamento CE 1935/2004-MOCA

	<b>TEB1/070E</b>	5,4 400V3N~ 50/60Hz	700	700/760	850	<b>6.311,00</b>
	<b>TEB1/080E</b>		800	700/760	850	<b>6.424,00</b>
	<b>TEB1/090E</b>		900	700/760	850	<b>6.538,00</b>
	<b>TEB2/100E</b>	10,8 400V3N~ 50/60Hz	1.000	700/760	850	<b>8.750,00</b>
	<b>TEB2/120E</b>		1.200	700/760	850	<b>9.013,00</b>
	<b>TEB2/140E</b>		1.500	700/760	850	<b>9.349,00</b>
	<b>TEB3/120E</b>	16,2 400V3N~ 50/60Hz	1.200	700/760	850	<b>11.307,00</b>
	<b>TEB3/140E</b>		1.400	700/760	850	<b>11.520,00</b>
	<b>TEB3/160E</b>		1.600	700/760	850	<b>11.825,00</b>
	<b>TEB4/160E</b>	21,6 400V3N~ 50/60Hz	1.600	700/760	850	<b>13.581,00</b>
	<b>TEB4/180E</b>		1.800	700/760	850	<b>13.991,00</b>
	<b>TER4/200E</b>		2.000	700/760	850	<b>14.934,00</b>
	<b>TER5/200E</b>	27,0 400V3N~ 50/60Hz	2.000	700/760	850	<b>16.793,00</b>
	<b>TER5/210E</b>		2.100	700/760	850	<b>16.966,00</b>
	<b>TER5/220E</b>		2.200	700/760	850	<b>17.141,00</b>

Accessori in dotazione nr.1 raschietto - Accessories included nr.1 scraper - Zubehöre inbegriffen nr.1 Schaber - Accessories inclus nr.1 raclette - Accesorios incluidos nr.1 rascador

**TEPPANYAKI**

**TEPPANYAKI****PIASTRA PER COTTURA GIAPPONESE**JAPANESE HOT PLATE - JAPANISCHE BRATPLATTE - PLAQUE JAPONAIS -  
PLACAS JAPONESAS

Model

kW

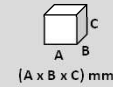

(A x B x C) mm

€

**TEM**

cod. TEM4B/160E

Versione da banco - Bench model - Aufschmodell - Modèle à poser - Modelo de sobremesa

Versione con piastra cromata - Chromium plate version - Ausführung mit Chromplatte - Version avec plaque chromée - Versión con plancha cromada

	TEM1B/070E	⚡ 5,4 400V3N~ 50/60Hz	700	700/760	330	5.552,00
	TEM1B/080E		800	700/760	330	5.644,00
	TEM1B/090E		900	700/760	330	5.737,00
	TEM2B/100E	⚡ 10,8 400V3N~ 50/60Hz	1.000	700/760	330	7.859,00
	TEM2B/120E		1.200	700/760	330	8.117,00
	TEM2B/140E		1.400	700/760	330	8.505,00
	TEM3B/120E	⚡ 16,2 400V3N~ 50/60Hz	1.200	700/760	330	10.106,00
	TEM3B/140E		1.400	700/760	330	10.435,00
	TEM3B/160E		1.600	700/760	330	10.765,00
	TEM4B/160E	⚡ 21,6 400V3N~ 50/60Hz	1.600	700/760	330	12.741,00
	TEM4B/180E		1.800	700/760	330	13.055,00
	TEM4B/200E		2.000	700/760	330	13.383,00
	TEM5B/200E	⚡ 27,0 400V3N~ 50/60Hz	2.000	700/760	330	15.149,00
	TEM5B/210E		2.100	700/760	330	15.312,00
	TEM5B/220E		2.200	700/760	330	15.475,00

Accessori in dotazione nr.1 raschietto - Accessories included nr.1 scraper - Zubehöre inbegriffen nr.1 Schaber - Accessories inclus nr.1 raclette - Accesorios incluidos nr.1 rascador

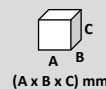
**TEPPANYAKI****PIASTRA PER COTTURA GIAPPONESE**JAPANESE HOT PLATE - JAPANISCHE BRATPLATTE - PLAQUE JAPONAIS -  
PLACAS JAPONESAS**TEM**

(A x B x C) mm

€

cod. TEM3/120E

Modello su vano a giorno - Model on open cabinet - Modell mit offenem Unterbau - Modèle sur meuble ouvert - Modelo abierto						
Versione con piastra cromata - Chromium plate version - Ausführung mit Chromplatte - Version avec plaque chromée - Versión con plancha cromada						
	<b>TEM1/070E</b>	5,4 400V3N~ 50/60Hz	700	700/760	850	<b>6.216,00</b>
	<b>TEM1/080E</b>		800	700/760	850	<b>6.328,00</b>
	<b>TEM1/090E</b>		900	700/760	850	<b>6.438,00</b>
	<b>TEM2/100E</b>	10,8 400V3N~ 50/60Hz	1.000	700/760	850	<b>8.618,00</b>
	<b>TEM2/120E</b>		1.200	700/760	850	<b>8.878,00</b>
	<b>TEM2/140E</b>		1.400	700/760	850	<b>9.045,00</b>
	<b>TEM3/120E</b>	16,2 400V3N~ 50/60Hz	1.200	700/760	850	<b>11.140,00</b>
	<b>TEM3/140E</b>		1.400	700/760	850	<b>11.349,00</b>
	<b>TEM3/160E</b>		1.600	700/760	850	<b>11.648,00</b>
	<b>TEM4/160E</b>	21,6 400V3N~ 50/60Hz	1.600	700/760	850	<b>13.432,00</b>
	<b>TEM4/180E</b>		1.800	700/760	850	<b>13.780,00</b>
	<b>TEM4/200E</b>		2.000	700/760	850	<b>14.192,00</b>
	<b>TEM5/200E</b>	27,0 400V3N~ 50/60Hz	2.000	700/760	850	<b>15.956,00</b>
	<b>TEM5/210E</b>		2.100	700/760	850	<b>16.121,00</b>
	<b>TEM5/220E</b>		2.200	700/760	850	<b>16.286,00</b>

Accessori in dotazione nr.1 raschietto - Accessories included nr.1 scraper - Zubehöre inbegriffen nr.1 Schaber - Accessories inclus nr.1 raclette - Accesorios incluidos nr.1 rascador

**TEPPANYAKI**

# TEPPANYAKI

## PIASTRE TEPPANYAKI SPECIALI

SPECIAL TEPPANYAKI PLATES - BESONDERE TEPPANYAKIPLATTEN - PLAQUES TEPPANYAKI SPÉCIALES - PLACAS TEPPANYAKI ESPECIALES

TEPPANYAKI



Model	kW	 (A x B x C) mm	€
-------	----	---	---

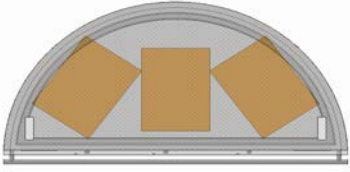

Versione con piastra cromata - Chromium plate version - Ausführung mit Chromplatte - Version avec plaque chromée - Versión con plancha cromada

	<b>TEH3/160E</b>	⚡ 16,2 400V3N~ 50/60Hz	1600	800	850	<b>16.216,00</b>
---	------------------	------------------------------	------	-----	-----	------------------



Versione con piastra cromata - Chromium plate version - Ausführung mit Chromplatte - Version avec plaque chromée - Versión con plancha cromada





	<b>TEX4/120E</b>	⚡ 21,6 400V3N~ 50/60Hz	1200	1200	850	<b>15.337,00</b>
---	------------------	------------------------------	------	------	-----	------------------

Accessori in dotazione nr.1 raschietto - Accessories included nr.1 scraper - Zubehöre inbegriffen nr.1 Schaber - Accessories inclus nr.1 raclette - Accesorios incluidos nr.1 rascador

# TEPPANYAKI

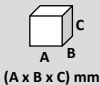
## PIASTRA PER COTTURA GIAPPONESE

JAPANESE HOT PLATE - JAPANISCHE BRATPLATTE - PLAQUE JAPONAIS -  
PLACAS JAPONESAS

	Model	 (A x B x C) mm	Description	€
<b>ACCESSORI</b> ACCESSORIES - ZUBEHÖRE - ACCESSOIRES - ACCESORIOS				
	<b>CH.700</b>	700	Chiusura con portine	<b>281,00</b>
	<b>CH.800</b>	800	Cupboard closed with doors	<b>330,00</b>
	<b>CH.900</b>	900	Schrank mit Flügeltüren geschlossen	<b>413,00</b>
	<b>CH.1000</b>	1.000	Armoire fermé avec portes Armario cerrado con puertas	<b>421,00</b>
	<b>CH.1100</b>	1.100	Chiusura con porte scorrevoli Cupboard closed with sliding doors Schrank mit Schiebetüren geschlossen Armoire fermé avec portes coulissante Armario cerrado con puertas deslizantes	<b>429,00</b>
	<b>CH.1200</b>	1.200		<b>436,00</b>
	<b>CH.1300</b>	1.300		<b>445,00</b>
	<b>CH.1400</b>	1.400		<b>453,00</b>
	<b>CH.1500</b>	1.500		<b>463,00</b>
	<b>CH.1600</b>	1.600		<b>469,00</b>
	<b>CH.1700</b>	1.700		<b>479,00</b>
	<b>CH.1800</b>	1.800		<b>485,00</b>
	<b>CH.1900</b>	1.900		<b>494,00</b>
	<b>19/85900001</b>		Raschietto lama intercambiabile Scraper with changeble blade for Teppanyaki Schaber mit Auswechselbaren Klinge	<b>50,00</b>

TEPPANYAKI



# yakitori



## ASIA









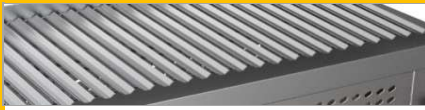

L'UNICA ED ORIGINALE LINEA ETNICA **MADE IN ITALY**

# yakitori

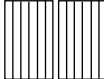
## YAKITORI GAS



GAS YAKITORI - GAS YAKITORI - YAKITORI A GAZ - YAKITORI A GAS

YAKITORI

	Model	 (A x B x C) mm	kW	Dim. Grid	€
				Grid	
Versione da banco - Bench model - Aufschmodell - Modèle à poser - Modelo de sobremesa					
	YAK1	740x320x270h	 6,0	600x270 	2.072,00
	TR.YAK1	715x270x580h			397,00
	YAK2	1.440x320x270h	 12,0	1.200x270 	3.107,00
	TR.YAK2	1430x270x580h			587,00

### YAKITORI ELETTRICA

ELECTRIC YAKITORI - ELEKTRO YAKITORI - YAKITORI ÉLECTRIQUE - YAKITORI ELÉCTRICAS

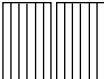
	YAK1E	760x300x270h	 2,2  230V~ 50/60Hz		2.602,00
---	-------	--------------	---	---	----------

# FRY-TOP



# FRY TOP

## PIASTRA FRY-TOP CUOCIPIADINA E SALSICCIA

FRY-TOP FOR PIADINA AND SAUSAGES - GRILLPLATTE FÜR PIADINA

HACKFLEISHWURST - PLAQUE FRY-TOP POUR CUISSON DE PIADINA ET SAUCISSE -

PLANCHA FRY-TOP PARA PIADINA E SALCHICHA

	Model	kW	 (A x B x C) mm			€
Versione da banco - Bench model - Aufschischmodell - Modèle à poser - Modelo de sobremesa						
	FTSPS/1G1PK.BB	19,8	1.020	530	255	3.124,00
	FTSPS/2GK.BB	26,0	1.260	530	255	3.556,00
Modello su trespolo - Model with support - Modell mit Gestell - Modèle sur support - Modelo con soporte						
	FTSPS/1G1PK.GG	19,8	1.020	530	850	3.407,00
	FTSPS/2GK.GG	26,0	1.260	530	850	3.887,00
<b>K</b> - Piastra conforme a normativa CE 1935/2004-MOCA - Plate in compliance with EC 1935/2004 Regulation-FCM - LKM-Platte konform mit CE 1935/2004 - Plaque en ligne avec le règlement CE 1935/2004-MCDA - Plancha conforme al reglamento CE 1935/2004-MOCA						

# FRY TOP

## PIASTRA FRY-TOP CUOCIPIADINA E SALSICCIA

FRY-TOP FOR PIADINA AND SAUSAGES - GRILLPLATTE FÜR PIADINA

HACKFLEISHWURST - PLAQUE FRY-TOP POUR CUISSON DE PIADINA ET SAUCISSE -

PLANCHA FRY-TOP PARA PIADINA E SALCHICHA

	Model	kW		 (A x B x C) mm		€
Modello su vano a giorno - Model on open cabinet - Modell mit offenem Unterbau - Modèle sur meuble ouvert - Modelo abierto						
	FTSPS/1G1PK.BA	19,8	1.020	530	850	3.703,00
	FTSPS/2GK.BA	26,0	1.260	530	850	4.241,00
Con portine o scorrevoli - Closed with doors or sliding doors - Mit Tür or mit Schiebetüren geschlossen - Fermée avec portes - Con armadio con puertas						
	FTSPS/1G1PK.BC	19,8	1.020	530	850	4.131,00
	FTSPS/2GK.BC	26,0	1.260	530	850	4.754,00
K - Piastra conforme a normativa CE 1935/2004-MOCA - Plate in compliance with EC 1935/2004 Regulation-FCM - LKM-Platte konform mit CE 1935/2004 - Plaque en ligne avec le règlement CE 1935/2004-MCDA - Plancha conforme al reglamento CE 1935/2004-MOCA						

FRY-TOP

# FRY TOP

## PIASTRA FRY-TOP CUOCIPIADINA E SALSICCIA

FRY-TOP FOR PIADINA AND SAUSAGES - GRILLPLATTE FÜR PIADINA

HACKFLEISHWURST - PLAQUE FRY-TOP POUR CUISSON DE PIADINA ET SAUCISSE -

PLANCHA FRY-TOP PARA PIADINA E SALCHICHA

	Model	kW	 (A x B x C) mm			€
Versione da banco - Bench model - Auf Tischmodell - Modèle à poser - Modelo de sobremesa						
	<b>FTSPS/102EK.BB</b>	4,4 ⚡ 230V o 400V 50/60Hz	1.020	530	255	<b>3.888,00</b>
	<b>FTSPS/126EK.BB</b>	4,4 ⚡ 230V o 400V 50/60Hz	1.260	530	255	<b>4.431,00</b>
Modello su trespolo - Model with support - Modell mit Gestell - Modèle sur support - Modelo con soporte						
	<b>FTSPS/102EK.GG</b>	4,4 ⚡ 230V o 400V 50/60Hz	1.020	530	850	<b>4.173,00</b>
	<b>FTSPS/126EK.GG</b>	4,4 ⚡ 230V o 400V 50/60Hz	1.260	530	850	<b>4.762,00</b>
<b>K - Piastra conforme a normativa CE 1935/2004-MOCA - Plate in compliance with EC 1935/2004 Regulation-FCM - LKM-Platte konform mit CE 1935/2004 - Plaque en ligne avec le règlement CE 1935/2004-MCDA - Plancha conforme al reglamento CE 1935/2004-MOCA</b>						

# FRY TOP

## PIASTRA FRY-TOP CUOCIPIADINA E SALSICCIA

FRY-TOP FOR PIADINA AND SAUSAGES - GRILLPLATTE FÜR PIADINA

HACKFLEISHWURST - PLAQUE FRY-TOP POUR CUISSON DE PIADINA ET SAUCISSE -

PLANCHA FRY-TOP PARA PIADINA E SALCHICHA

	Model	kW	 (A x B x C) mm	€
Modello su vano a giorno - Model on open cabinet - Modell mit offenem Unterbau - Modèle sur meuble ouvert - Modelo abierto				
	FTSPS/102EK.BA	4,4 ⚡ 230V o 400V 50/60Hz	1.020 530 850	4.468,00
	FTSPS/126EK.BA	4,4 ⚡ 230V o 400V 50/60Hz	1.260 530 850	5.115,00
Con portine o scorrevoli - Closed with doors or sliding doors - Mit Tür or mit Schiebetüren geschlossen - Fermée avec portes - Con armadio con puertas				
	FTSPS/102EK.BC	4,4 ⚡ 230V o 400V 50/60Hz	1.020 530 850	4.897,00
	FTSPS/126EK.BC	4,4 ⚡ 230V o 400V 50/60Hz	1.260 530 850	5.628,00
K - Piastra conforme a normativa CE 1935/2004-MOCA - Plate in compliance with EC 1935/2004 Regulation-FCM - LKM-Platte konform mit CE 1935/2004 - Plaque en ligne avec le règlement CE 1935/2004-MCDA - Plancha conforme al reglamento CE 1935/2004-MOCA				

FRY-TOP



# BroilyGrill®



## CHANGE YOUR WAY TO GRILL WITH BROILYGRILL



Cos'è BroilyGrill? Finalmente la soluzione ideale, il sogno di ogni griller, un broiler a cottura diretta ad altissima temperatura, il perfect total searing in una cucina professionale. Direttamente dall'esperienza USA, il BBQ 100% Made in Italy costruito da CASTA Professional Cooking Equipment, studiato per le migliori steakhouses, hamburgerie, bracerie, pub, ristoranti, utilizza sistemi di riscaldamento sia a gas che elettrici di nuova generazione, in grado di raggiungere 850°C in pochi minuti di preriscaldamento, riducendo drasticamente i tempi di cottura tradizionali. Inoltre, il posizionamento della fonte di calore nella parte superiore consente una cottura a irraggiamento diretto, creando una reazione di Maillard immediata e un perfect total searing non riproducibile con altre tecniche, evitando la fastidiosa emissione di fumo, fiamme, e odori causati dai sistemi classici. Broilygrill rappresenta la rivoluzione professionale, un prodotto con altissimo rendimento, semplice da utilizzare, perfetto per le cucine a vista, adatto a molteplici usi.

## VANTAGGI

- **850°C in pochi minuti** di preriscaldamento
- **RIDUZIONE 50% TEMPI DI COTTURA:** grazie alle alte temperature raggiunte i tempi di cottura vengono ridotti mediamente del 50%, con conseguente incremento della produttività.
- **RIDUZIONE 80% FUMO E ODORI:** la cottura inversa con irraggiamento del calore dall'alto riduce drasticamente fino all'80% la quantità di fumo e odori che si sviluppano normalmente nei sistemi classici.
- **STOP A FIAMME:** grazie alla cottura inversa dall'alto verso il basso, non avremo più le fiamme, le bistecche bruciate o fredde al cuore, odori sgradevoli ed il fumo causati dalla pirolisi dei grassi che cadono sulla fonte di calore nei sistemi di cottura tradizionale.
- **STOP A BISTECHE BRUCIATE E/O FREDDE AL CUORE**
- **PERFECT TOTAL SEARING** I tre principi di cottura fondamentali - irraggiamento - conduzione - convezione presenti in una unica macchina. Tutte le cotture dirette - hamburger- costate- fiorentine - tomahawk - fettine a basso spessore di pollo-maiale-agnello (carne bianca e rossa) avranno una Maillard incredibile, brasature perfette e omogenee, con una succulenza ineguagliabile.
  - o **Cottura per irraggiamento:** posizionamento della fonte di calore nella parte superiore con emissione dall'alto verso il basso,
  - o **Cottura per conduzione:** le griglie ad alto spessore assicurano la conduzione dal basso verso l'alto del calore accumulato, attraverso il contatto diretto con il cibo
  - o **Cottura per convezione naturale:** la cassa del BBQ crea l'"effetto forno", una convezione naturale grazie al calore accumulato, che cuoce la corona dell'ingrediente (parte esterna laterale) in modo perfetto ed omogenea (perfect total searing). Nei sistemi di cottura tradizionale si deve appoggiare la parte laterale della bistecca, girandola più volte, direttamente sulla griglia affinché si raggiunga la doratura.
- **REAZIONE DI MAILLARD PERFETTA:** doratura superficiale della carne che avviene ad alte temperature, tra i 140°C e i 180 °C, reazione tra gli amminoacidi delle proteine e gli zuccheri. Questo significa che l'imbrunimento può avvenire solo sulla superficie della carne: internamente è sempre presente dell'acqua che le impedisce di superare i 100 °C. L'alta temperatura sviluppata all'interno della BroilyGrill sigilla immediatamente i pori degli alimenti creando una doratura esterna eccezionale ed uniforme su tutta la carne, anche sulla parte laterale, e blocca i succhi all'interno, ottenendo un prodotto succulento.
- **T&T BROILYPROCESS :** attraverso l'utilizzo del Timer e Termometro riusciamo a creare un processo di lavoro ripetibile e standardizzato in cucina, con conseguente semplificazione del lavoro. Inoltre con la semplice misurazione della temperatura interna della carne potrai decidere il punto di cottura desiderato.
- **CALO PESO RIDOTTO:** l'alta temperatura sigilla immediatamente i pori degli alimenti bloccando i succhi all'interno, riducendo al minimo il calo peso del cibo.
- **COTTURA SALUTARE E CIBO SANO:** l'assenza di fumo da pirolisi garantisce un prodotto sano, salutare, altamente digeribile, non inquinato dalla combustione di grassi e succhi che cadono sulla fonte di calore nei sistemi tradizionali di cottura.
- **VELOCITA' DI RISCALDAMENTO:** BroilyGrill raggiunge 850°C in pochi minuti. Accendo il pilota ed aspetto la comanda.
- **RISPARMIO ENERGETICO:** la velocità di riscaldamento e cottura permettono l'utilizzo della macchina solo in caso di necessità, eliminando inutili sprechi con un risparmio energetico fino al 50%.
- **VERSATILITA':** Abbinato alla CBT (cottura a bassa temperatura) o BATCH (precottura e abbattimento di cibi in linea batch) con finitura in griglia è la massima espressione della cucina gourmet e libera la creatività degli chef stellati offrendo lo strumento per cucinare pollo-maiale- bistecche ad alto spessore con osso- verdure -crostacei in modo sublime.
- **FACILE PULIZIA:** griglie di cottura e vaschette (water pans), smontabili e lavabili in lavastoviglie, pulizia della cassa interna con foro di scarico sul fondo

# BroilyGrill® BROILYGRILL

BROILYGRILL - BROILYGRILL - BROILYGRILL - BROILYGRILL

## CHANGE YOUR WAY TO GRILL WITH BROILYGRILL



### What is BroilyGrill?

It is the ideal solution, the dream of every griller, a high temperature direct cooking broiler, the perfect total searing in a professional kitchen.

Directly from the USA experience, this 100% Made in Italy BBQ is designed for the best steakhouses, burgeries, pubs, restaurants, with new generation gas burners, honeycomb ceramic plates capable of reaching 850 °C in a few minutes of preheating, drastically reducing traditional cooking times.

Furthermore, the positioning of the heat source in the upper part allows for a direct radiation cooking, creating an immediate Maillard reaction and a perfect total searing never seen before, avoiding the annoying emission of smoke, flames, and smells caused by the classic systems of cooking. Broilygrill represents the professional revolution, a very high-performance appliance, simple to use, perfect for show cooking kitchens, suitable for multiple uses.

## ADVANTAGES

- **850°C in few minutes** of preheating.
- **50% REDUCTION OF COOKING TIMES:** thanks to the reached high temperatures, cooking times are reduced on average by 50%, with a consequent increase in productivity.
- **80% SMOKE AND ODOR REDUCTION:** reverse cooking with heat radiation from above drastically reduces the amount of smoke that normally develops in classic systems up to 80%
- **STOP FLAMES:** thanks to the reverse cooking from top to bottom, we will no longer have flames, burnt or cold steaks to the heart, unpleasant smells and smoke caused by the pyrolysis of fats that fall on the heat source in traditional cooking systems.
- **STOP BURNT AND/OR COLD STEAKS TO THE CORE**
- **PERFECT TOTAL SEARING:** the three basic cooking principles (radiation, conduction and convection) are available in a single machine. All the direct cooking white and red meat (hamburger, ribs, Fiorentina steaks, tomahawk, thin slices of chicken, pork or lamb) will have a fantastic Maillard, a perfect and homogeneous brazing, with an incomparable succulence.
  - o **Cooking by radiation:** the heating source is placed in the upper part, with emission from top to bottom
  - o **Cooking by conduction:** the grids with high thickness assure the conduction of the accumulated heat from bottom to top, through direct contact with food
  - o **Cooking by natural convection:** the BBQ case creates the "oven effect", a natural convection effect thanks to the accumulated heat, that cooks the crown of the food (the outer side) in a perfect and homogeneous way (perfect total searing). In traditional cooking systems You have to place the side of the steak, and turning it multiple times to reach the browning.
- **PERFECT MAILLARD'S REACTION:** it is the superficial browning of the meat that happens between 140 °C and 180 °C, as consequence of the chemical reaction between amino acids belonging to proteins and sugars. This means that the browning may happen only on the surface of the steak: on the inside there is always water that prevents to reach temperatures higher than 100 °C. The high temperature developed inside BroilyGrill immediately seals the pores of the food creating an exceptional and uniform outer browning on all the meat, even on the sides, and blocks the juices inside, obtaining a succulent product.
- **T&T BROILYPROCESS :** through the use of the Timer and Thermometer we are able to create a repeatable and standardized work process in the kitchen, with consequent simplification of the work. Furthermore, with the simple measurement of the meat core temperature you can decide the desired cooking point.
- **REDUCED WEIGHT LOSS:** the high temperature developed inside BroilyGrill immediately seals the food pores blocking inside the food juices, obtaining a succulent product, minimally reducing the food weight loss.
- **HEALTHY COOKING AND FOOD:** the absence of a pyrolysis smoke is a warranty of a healthy and highly digestible food, untouched by the fat burning and juices dropping on the heating source like in traditional cooking systems.
- **HEATING SPEED:** BroilyGrill reaches 850 °C in few minutes. You turn on the pilot and wait for the order.
- **ENERGY SAVING:** the speed of heating and cooking allows the machine to be used only in case of need, deleting unnecessary energy waste, with an energy saving up to 50%.
- **VERSATILITY:** Combined to LTC (low temperature cooking) or BATCH (pre-cooking and temperature lowering of food in BATCH line) with grill finishing it is the maximum expression of gourmet cuisine and it boosts the creativity of starred chefs by offering the tool to cook chicken, pork, thick steaks with bone, vegetables and shellfish in a sublime way.
- **EASY CLEANING:** cooking grills and water pans are removable and dishwasher safe. It is possible to clean the internal casing with drain hole on the bottom.

## CHANGE YOUR WAY TO GRILL WITH BROILYGRILL



¿Que es BroilyGrill? Es la solution ideal, el sueño de cada griller, un broiler a cocción directa a muy alta temperatura, el perfect total searing en una cocina profesional.

Directamente de la experiencia de los Estados Unidos, es el BBQ 100% Made in Italy diseñado para las mejores churrasquerías, hamburgueserías, pubs, restaurantes; utiliza quemadores de gas de nueva generación, placas de cerámica alveolar que alcanzan los 850°C en unos minutos de precalentamiento, reduciendo drásticamente los tiempos de cocción tradicionales.

Además, el posicionamiento de la fuente de calor en la parte superior permite la cocción por irradiación directa, creando una reacción de Maillard inmediata y un sellado perfecto nunca antes visto, evitando la molesta emisión de humo, llamas y olores que provocan los sistemas clásicos.

Broilygrill representa la revolución profesional, un producto con muy alto rendimiento, simple da utilizar, perfecto para las cocinas abiertas, adecuados para múltiples usos.

## VENTAJAS

- **850°C en poco minutos de precalentamiento**
- **REDUCCIÓN DEL 50% DE LOS TIEMPOS DE COCCIÓN:** a las altas temperaturas alcanzadas, los tiempos de cocción son reducidos en media del 50%, con el consiguiente aumento de la productividad.
- **80% DE REDUCCIÓN DE HUMOS Y OLORES:** la cocción inversa con irradiación del calor desde arriba reduce drásticamente hasta el 80% la cantidad de humo que normalmente se desarrolla en los sistemas clásicos
- **STOP A LAS LLAMAS:** gracias a la cocción inversa de arriba a abajo, ya no tendremos llamas, filetes quemados o fríos hasta el corazón, olores desagradables y humos provocados por la pirólisis de las grasas que caen sobre la fuente de calor en los sistemas de cocción tradicionales.
- **STOP FILETES QUEMADOS Y/O FRÍOS HASTA EL CORAZÓN**
- **PERFECT TOTAL SEARING:** Los tres principios de cocción fundamentales (irradiación, conducción, convección) en un solo producto. Todas las cocciones directas – hamburger- costillas- Florentina- tomahawk- lonchas finas de pollo-cerdo-cordero (carne blanca y roja) tendrán una Maillard increíble, braseadas perfectamente y homogéneamente, con una succulencia incomparable.
  - o **Cocción por irradiación:** colocación de la fuente de calor en la parte superior con emisión de arriba a abajo.
  - o **Cocción por conducción:** las rejillas de alto espesor aseguran la conducción de abajo hacia arriba del calor acumulado, a través del contacto directo con los alimentos.
  - o **Cocción por convección natural:** la caja del BBQ crea el "efecto horno", una convección natural gracias al calor acumulado, que cocina la corona del ingrediente (parte externa lateral) de manera perfecta y homogéneamente (perfect total searing). En los sistemas de cocción tradicional se debe apoyar la parte lateral del filete, girándolo varias veces, directamente sobre la parrilla para que se alcance el dorado.
- **PERFECTA REACCIÓN DE MAILLARD:** es el dorado superficial de la carne que ocurre entre 140°C y 180°C, causado por la reacción química entre los aminoácidos de las proteínas y los azúcares. Esto significa que el dorado solo puede ocurrir en la superficie de la carne: internamente siempre hay agua que evita que supere los 100 °C. La alta temperatura desarrollada en el interior del BroilyGrill sella inmediatamente los poros de los alimentos creando un dorado externo excepcional y uniforme en toda la carne, incluso en los lados, y bloqueando los jugos en el interior, obteniendo un producto succulento.
- **T&T BROILYPROCESS:** a través del uso del Temporizador y el Termómetro somos capaces de crear un proceso de trabajo repetible y estandarizado en la cocina, con la consiguiente simplificación del trabajo. Además, con la simple medición de la temperatura interna de la carne podrás decidir el punto de cocción deseado.
- **REDUCCIÓN DE LA PÉRDIDA DE PESO:** La alta temperatura desarrollada dentro del BroilyGrill sella inmediatamente los poros de los alimentos bloqueando los jugos en su interior, obteniendo un producto succulento y minimizando la pérdida de peso del alimento.
- **COCCIÓN Y ALIMENTOS SALUDABLES:** la ausencia de humos de pirólisis garantiza un producto saludable, de alta digestibilidad, no contaminado por la combustión de grasas y jugos que caen sobre la fuente de calor en los sistemas de cocción tradicionales.
- **VELOCIDAD DE CALENTAMIENTO:** BroilyGrill llega a 850°C en unos minutos. Se enciende el piloto y se espera la orden.
- **AHORRO DE ENERGÍA:** la velocidad de calentamiento y cocción permiten el uso de la máquina solamente en caso de necesidad, eliminando el desperdicio de energía superfluo, con un ahorro de energía de hasta un 50%.
- **VERSATILIDAD:** Combinado con la CBT (cocción a baja temperatura) o cocina BATCH (precocción y abatimiento de alimentos en línea batch) con acabado sobre la parrilla, es la máxima expresión de la cocina gourmet y libera la creatividad de los chefs estrellados ofreciendo el instrumento para cocinar pollo, cerdo, filetes de ternera con hueso, verduras y mariscos de manera sublime.
- **FÁCIL LIMPIEZA:** Rejillas y bandejas de cocción extraíbles y adecuadas para lavavajillas, limpieza de la cámara interna con agujero de drenaje en la parte inferior.

# BroilyGrill®

**BROILYGRILL**

BROILYGRILL - BROILYGRILL - BROILYGRILL - BROILYGRILL

## CHANGE YOUR WAY TO GRILL WITH BROILYGRILL



Enfin la solution idéale, le rêve de tous les Griller, un Broiler à cuisson direct et très haute température, le perfect total searing dans une cuisine professionnelle. Directement issu de l'expérience USA, le bbq 100% Made in Italy est conçu pour les meilleurs steakhouses, chaînes de hamburgers, brasseries, pubs, restaurants. Il utilise des brûleurs à gaz de nouvelle génération : des plaques en céramique nid d'abeille capables d'atteindre 850 °C en quelques minutes de préchauffage, réduisant nettement les temps de cuisson traditionnels. En outre, l'emplacement de la source de chaleur dans la partie supérieure permet une cuisson par rayonnement direct, créant une réaction de Maillard immédiate et un perfect total searing jamais vu auparavant, évitant ainsi l'émission gênante de fumée, de flammes et d'odeurs causées normalement par les systèmes classiques. Broilygrill représente une révolution professionnelle : un produit à haute performance, facile à utiliser, parfait pour les cuisines à vue, adapté à de multiples usages.

## ADVANTAGES

- **850°C** en quelques minutes de préchauffage
- **REDUCTION 50% DES TEMPS DE CUISSON**: grâce aux hautes températures atteintes, le temps de cuisson est réduit de 50% en moyenne, ce qui permet une augmentation de la productivité.
- **REDUCTION 80% FUMÉE ET ODEURS**: la cuisson inversée avec rayonnement thermique par le haut, réduit considérablement jusqu'à 80 % la quantité de fumée et odeurs qui se développe normalement dans les systèmes classiques
- **PLUS DE FLAMME**: grâce à la cuisson inversée du haut vers le bas, nous pouvons oublier les flammes ou la viande froide au cœur, les odeurs désagréables et la fumée causée par la pyrolyse des graisses qui tombent sur la source de chaleur dans les systèmes de cuisson traditionnels.
- **PLUS DE VIANDE BRULÉE ET/OU FROID AU COEUR**
- **PERFECT TOTAL SEARING**: les trois principes de base de cuisson - rayonnement - conduction - convection - réunis dans un seul produit. Toutes les cuissons directes - hamburgers, ribs, steak florentin, tomahawk, tranches fines de poulet, porc ou agneau (viande blanche et rouge) auront un Maillard surprenant, un braisage parfait et homogène, d'une succulence incomparable.

- o **Cuisson par rayonnement** : positionnement de la source de chaleur dans la partie supérieure avec émission de haut vers le bas ;
- o **Cuisson par conduction** : les grilles de grande épaisseur assurent la conduction de bas vers le haut de la chaleur accumulée à travers le contact direct avec les ingrédients;

- o **Cuisson par convection** : le boîtier du bbq crée un 'effet four', une convection naturelle grâce à la chaleur accumulée qui cuit parfaitement et uniformément la couronne (la partie extérieure latérale) de l'ingrédient (perfect total searing). Dans les systèmes de cuisson traditionnels, la partie latérale du steak doit être placée, en la retournant plusieurs fois, directement sur la grille pour qu'elle soit dorée.

- **REACTION MAILLARD PARFAITE** : il s'agit du brunissement superficiel de la viande qui se produit entre 140°C et 180°C, causé par la réaction chimique entre les acides aminés des protéines et les sucres. Cela signifie que le brunissement se produit seulement sur la surface de la viande : à l'intérieur, il y a toujours de l'eau qui l'empêche de dépasser 100 °C. La température élevée développée à l'intérieur du BroilyGrill scelle immédiatement les pores des aliments, en réalisant une cuisson externe exceptionnelle et uniforme de l'aliment, sur la partie latérale aussi, ce qui permet de bloquer les jus à son intérieur et d'obtenir un produit succulent

- **T&T BROILYPROCESS** : À travers l'utilisation d'un minuteur et d'un thermomètre, nous réussissons à créer dans la cuisine un processus de travail reproductible et standard qui permet de simplifier le travail. En plus, avec la mesure de la température à l'intérieur de la viande, vous pouvez choisir le point choisi de cuisson.

- **PERTE DE POIDS REDUITE** : la température élevée développée à l'intérieur du BroilyGrill scelle immédiatement les pores des aliments, en bloquant les jus à son intérieur, ce qui permet d'obtenir un produit succulent et de réduire la perte de poids des aliments.

- **TIPOLOGIE DE CUISSON ET ALIMENTATION SAINES** : l'absence de fumée de pyrolyse garantit un produit sain, hautement digestible, non pollué par la combustion des graisses et des jus qui tombent sur la source de chaleur dans les systèmes de cuisson traditionnels.

- **VITESSE DE CHAUFFAGE** : BroilyGrill arrive à 850°C en quelques minutes. Il suffit d'allumer la veilleuse et d'attendre la commande.

- **ÉCONOMIE D'ÉNERGIE**: la rapidité de chauffage et de cuisson vous permet d'utiliser l'équipement seulement en cas de nécessité, en éliminant ainsi les gaspillages d'énergie et en économisant jusqu'à un 50%.

- **POLYVALENCE** : Combiné avec la CBT (cuisson basse température) ou le BATCH COOKING (pré-cuisson et refroidissement rapide des aliments comme planification) avec terminaison sur la grille, c'est le maximum de l'expression de la cuisine gourmet. Stimule la créativité des chefs étoilés grâce à un instrument pour la cuisson de poulet, porc, bifteck de grosse épaisseur avec l'os, légumes et fruits de mer dans un manière impeccable.

- **NETTOYAGE FACILE** : les grilles et les plateaux de cuisson sont amovibles et lavables au lave-vaisselle. Nettoyage de la structure intérieure à l'aide d'un trou de vidange situé au fond.





**BROILYGRILL**

	Model	 (A x B x C) mm	kW 		Dim. cooking plate mm.	Griglie mm. 232x380	€
	<b>BRL7001</b>	740x450/630x745h	 8,3	gas	470x380	2	<b>4.997,00</b>
	<b>BRE7001M</b>	800x450/630x745h	 5,0	1Nac230V 50/60 Hz 32A	470x380	2	<b>5.254,00</b>
	<b>BRE7001</b>			3Nac400V 50/60 Hz 16A			<b>5.120,00</b>
	<b>BRL8001</b>	980x450/630x745h	 12,8	gas	700x380	3	<b>5.817,00</b>
	<b>BRE8001</b>	1040x450/630x745h	 10,0	3Nac400V 50 Hz 32A	700x380	3	<b>5.942,00</b>

	Model	 (A x B x C) mm	Description	€
	BRTCS7001P	800x700x850h	Base inox chiusa con antina, con piano intermedio regolabile, con n. 1 cassetto mm.555x580x145h, su piedi / Stainless stell cabinet with door, adjustable intermediate shef, n.1 drawer mm.555x580x145h, with feet	<b>1.649,00</b>
	BRTCS7001R	800x700x860h	Base inox chiusa con antina, con piano intermedio regolabile, con n. 1 cassetto mm.555x580x145h, su ruote (n. 2 con freno + n.2 senza freno) / Stainless stell cabinet with door, adjustable intermediate shef, n.1 drawer mm.555x580x145h, with n.4 wheels (n. 2 with break)	<b>1.750,00</b>
	BRTCS8001P	1.040x700x850h	Base inox chiusa con antine, con piano intermedio regolabile, con n. 2 cassetti mm.375x580x145h, su piedi / Stainless stell cabinet with door, adjustable intermediate shef, n.2 drawers mm.555x580x145h, with feet	<b>2.152,00</b>
	BRTCS8001R	1.040x700x860h	Base inox chiusa con antine, con piano intermedio regolabile, con n. 2 cassetti mm.375x580x145h, su ruote (n. 2 con freno + n.2 senza freno) / Stainless stell cabinet with door, adjustable intermediate shef, n.2 drawers mm.555x580x145h, with n.4 wheels (n. 2 with break)	<b>2.252,00</b>
	BRTEG7001P	800x700x850h	Base inox con portateglie cap. n. 5 GN 1/1 h.100 mm (GN escluse), con piano intermedio regolabile, su piedi / Stainless stell cabinet with side runner cap. n. 5 GN 1/1 h.100 mm (GN not included) with feet	<b>1.335,00</b>
	BRTEG7001R	800x700x860h	Base inox con portateglie cap. n. 5 GN 1/1 h.100 mm (GN escluse), con piano intermedio regolabile, su ruote (n. 2 con freno + n.2 senza freno) / Stainless stell cabinet with side runner cap. n. 5 GN 1/1 h.100 mm (GN not included) with n.4 wheels (n. 2 with break)	<b>1.435,00</b>

	Model	 (A x B x C) mm	Description	€
	<b>BRTEG8001P</b>	1.040x700x850h	Base inox con portateghe cap. n. 5 GN 1/1 h.100 mm (GN escluse), con piano intermedio regolabile, su piedi / Stainless stell cabinet with side runner cap. n. 5 GN 1/1 h.100 mm (GN not included) with feet	<b>1.503,00</b>
	<b>BRTEG8001R</b>	1.040x700x860h	Base inox con portateghe cap. n. 5 GN 1/1 h.100 mm (GN escluse), con piano intermedio regolabile, su ruote (n. 2 con freno + n.2 senza freno) / Stainless stell cabinet with side runner cap. n. 5 GN 1/1 h.100 mm (GN not included) with n.4 wheels (n. 2 with break)	<b>1.603,00</b>
	<b>BRCST8001P</b>	1.040x700x850h	Base inox con portateghe cap. n. 5 GN 1/1 h.100 mm (GN escluse), con cassetiera a 3 cassetti mm.355x580x145h, su piedi / Stainless stell cabinet with side runner cap. n. 5 GN 1/1 h.100 mm (GN not included) with n.3 drawers mm.355x580x145h with feet	<b>2.438,00</b>
	<b>BRCST8001R</b>	1.040x700x860h	Base inox con portateghe cap. n. 5 GN 1/1 h.100 mm (GN escluse), con cassetiera a 3 cassetti mm.355x580x145h, su ruote (n. 2 con freno + n.2 senza freno) / Stainless stell cabinet with side runner cap. n. 5 GN 1/1 h.100 mm (GN not included) with n.3 drawers mm.355x580x145h with n.4 wheels (n. 2 with break)	<b>2.538,00</b>
	<b>BRTCB7001P</b>	800x700x850h	Base inox chiusa con antina, con supporto bombola gas 10 kG diam.270x600h (bombola esclusa) su piedi / Stainless stell cabinet with support for gas bottle cap.10 kG diam.270x600h (gas bottle non included) with feet	<b>1.103,00</b>
	<b>BRTCB7001R</b>	800x700x860h	Base inox chiusa con antina, con supporto bombola gas 10 kG diam.270x600h (bombola esclusa) su ruote (n. 2 con freno + n.2 senza freno) / Stainless stell cabinet with support for gas bottle cap.10 kG diam.270x600h (gas bottle non included) with n.4 wheels (n. 2 with break)	<b>1.202,00</b>
	<b>BRTCB8001P</b>	1.040x700x850h	Base inox chiusa con antina, con n.2 supporti bombola gas 10 kG diam.270x600h (bombole escluse) su piedi / Stainless stell cabinet with support for n.2 gas bottles cap.10 kG diam.270x600h (gas bottle non included) with feet	<b>1.347,00</b>
	<b>BRTCB8001R</b>	1.040x700x860h	Base inox chiusa con antina, con n.2 supporti bombola gas 10 kG diam.270x600h (bombole escluse) su ruote (n. 2 con freno + n.2 senza freno) / Stainless stell cabinet with support for n.2 gas bottles cap.10 kG diam.270x600h (gas bottle non included) with n.4 wheels (n. 2 with break)	<b>1.448,00</b>

	Model	 (A x B x C) mm	Description	€
	<b>BRTRE7001P</b>	800x700x850h	Trespolo inox con piano di fondo, su piedi / Stainless stell support with feet	<b>712,00</b>
	<b>BRTRE8001P</b>	1.040x700x850h	Trespolo inox con piano di fondo, su piedi / Stainless stell support with feet	<b>765,00</b>
	<b>BRTRG7001P</b>	800x700x850h	Trespolo inox con portateglie cap. n. 5 GN 1/1 h.100 mm (GN escluse), su piedi / Stainless stell support with side runner cap. n. 5 GN 1/1 h.100 mm (GN not included) with feet	<b>949,00</b>
	<b>BRTRG8001P</b>	1.040x700x850h	Trespolo inox con portateglie cap. n. 5 GN 1/1 h.100 mm (GN escluse), su piedi / Stainless stell support with side runner cap. n. 5 GN 1/1 h.100 mm (GN not included) with feet	<b>1010,00</b>
	<b>SL/BGN10750</b>	463,4x369,7x 138,7h	Griglia inox cap. nr. 15 arrosticini mod. BRL7001 - BRE7001 / Stainless steel grid cap. nr. 15 little skewers (italian arrosticini) mod. BRL7001 - BRE7001	<b>304,00</b>
	<b>SL/BGN20750</b>	703,4x369,7x 138,7h	Griglia inox cap. nr. 23 arrosticini mod. BRL8001 - BRE8001 / Stainless steel grid cap. nr. 23 little skewers (italian arrosticini) mod. BRL8001 - BRE8001	<b>358,00</b>

	Model	 (A x B x C) mm	Description	€
	<b>21/BGN00001</b>	232x380	Griglia per BroilyGrill mm. 232x380, Verticale, in tondino acciaio inox AISI 304 Ø6mm / Vertical round Stainless steel AISI 304 grid for BroilyGrill mm. 232x380 Ø 6 mm.	<b>88,00</b>
 x2	<b>nr. 2 x 21/BGN00001</b>	nr. 2 x 232x380	Completo griglia per BroilyGrill mm. 232x380, Verticale, in tondino acciaio inox AISI 304 Ø6mm (nr. 2 pz) / Vertical round Stainless steel AISI 304 grid for BroilyGrill mm. 232x380 Ø 6 mm. (nr. 2 pcs)	<b>175,00</b>
 x3	<b>nr. 3 x 21/BGN00001</b>	nr. 3 x 232x380	Completo griglia per BroilyGrill mm. 232x380, Verticale, in tondino acciaio inox AISI 304 Ø6mm (nr. 3 pz) / Vertical round Stainless steel AISI 304 grid for BroilyGrill mm. 232x380 Ø 6 mm. (nr. 3 pcs)	<b>263,00</b>
	<b>BRDOC001</b>	/	Doccia BroilyGrill professionale con flessibile inox viplato mt. 1,5 attacco girevole 1/2" / Professional faucet tap BroilyGrill with flexible stainless steel 1.5 m swivel connection 1/2	<b>324,00</b>

# TEPP ICE

NEW SHOW ICE CREAM CONCEPT





TEPP-ICE  
TEPP-ICE

	Model	 (A x B x C) mm	kw	 (A x B x C) mm	€
	<b>DROP-IN VERSION</b>				
	<b>TEMP. MAX -38°C</b>	<b>External Dimensions</b>		<b>Internal Dimensions</b>	
	<b>DP/TPICE</b>	680x610	 1,23  230V~ 50/60Hz	610x560	<b>9.481,00</b>
	<b>FEBE</b>				
	<b>TEMP. MAX -38°C</b>	<b>External Dimensions</b>		<b>Internal Dimensions</b>	
	<b>TPICE800</b>	800x750x930h	 1,23  230V~ 50/60Hz	610x560	<b>11.394,00</b>
		Carrello su ruote con inserita DP/TPICE Trolley with DP/TPICE drop-in version			
	<b>ATENA</b>				
	<b>TEMP. MAX -38°C</b>	<b>External Dimensions</b>		<b>Internal Dimensions</b>	
	<b>TPICE1200</b>	1.200x750x 930/1.430h	 1,23  230V~ 50/60Hz	610x560	<b>14.849,00</b>
		Piano in granito - Cassettiera a 3 cassetti - Nr.6 GN 1/9 - Mensola in plexiglass - Nr.4 ruote Granite top - Nr.3 drawers - Nr.6 GN 1/9 - Plexiglass shelf - Nr.4 wheels			
	<b>ATENA R</b>				
	<b>TEMP. MAX -38°C</b>	<b>External Dimensions</b>		<b>Internal Dimensions</b>	
	<b>TPICE1200R</b>	1.200x750x 930/1.430h	 1,23  230V~ 50/60Hz	610x560	<b>A RICHIESTA / UPON REQUEST / SUR DEMANDE / SOBRE PEDIDO</b>
		Piano in granito - Cassettiera a 3 cassetti - Nr.4 GN 1/9 - Nr. 4 GN 1/9 refrigerate - Mensola in plexiglass - Nr.4 ruote Granite top - Nr.3 drawers - Nr.4 GN 1/9 - Nr. 4 refrigerated GN 1/9 - Plexiglass shelf - Nr.4 wheels			

**IL NUOVO SHOW ICE CREAM CONCEPT / NEW SHOW ICE CREAM CONCEPT**

Pensata appositamente per tutti i professionisti della gelateria, della ristorazione e dello street food, TEPP-ICE è la nuova frontiera del gusto. Grazie alla sua speciale piastra refrigerata, puoi preparare **granite, cocktail frozen, smoothy frozen, decorazioni di cioccolato, ice roll, dessert e tanto altro ancora.** / Designed specifically for all professionals in the ice cream, catering and street food sectors, TEPP-ICE is the new frontier of taste. Thanks to its special refrigerated plate, you can prepare granitas, frozen cocktails, frozen smoothies, chocolate decorations, ice cream rolls, desserts and much more.





**TEPP-TWIN**  
TEPP-TWIN



Model	 (A x B x C) mm	kW	 (A x B x C) mm	€
-------	--	----	--	---



**TEPPTWIN**



TT1	1.000x850x930h			21.759,00
HOT PLATE +240°C		1,85	290x580	
COLD PLATE MAX -38°C		0,90	300x600	
EXTRACTION SYSTEM		0,20	m <sup>3</sup> /h 1.220	
POTENZA TOTALE TOTAL POWER		 2,95 230V~ 50/60Hz		



TT2	1.600x850x930h			28.403,00
HOT PLATE +240°C		5,40	550x580	
COLD PLATE MAX -38°C		1,23	560x600	
EXTRACTION SYSTEM		0,20	m <sup>3</sup> /h 1.220	
POTENZA TOTALE TOTAL POWER		 6,83 400V3N~ 50/60Hz		



**TEPP-TWIN** è una macchina composta da due piastre indipendenti affiancate, che consentono la cottura fino a +240°C (a destra) e il raffreddamento rapido fino a -38°C (a sinistra). Unica e polivalente, offre agli chef più creativi la possibilità di inventare e realizzare ricette senza utilizzare altre risorse: dall'antipasto al dolce, passando per primi e secondi, il risultato è sempre un'armonia di sapori e colori. L'utilizzo della piastra fredda (fino dall'esaltazione dei principi nutrizionali a -38°C) favorisce l'abbattimento microbico e aiuta il fissaggio di colori e proprietà dei cibi. Il passaggio dalla piastra fredda a quella calda attiva lo shock termico che esalta il colore e la consistenza degli alimenti. Il piatto si va poi a terminare su una delle due piastre, in base alla ricetta desiderata.

TEPP-TWIN funziona elettricamente, ed è dotata di un sistema di aspirazione integrato autosufficiente con filtrazione a mezzo di n.1 filtro in viledon e n. 1 filtro a carboni attivi, con scarico libero in ambiente.

Il vantaggio principale nell'utilizzo di TEPP-TWIN è cucinare e raffreddare rapidamente i cibi, grazie alla presenza di un unico piano di lavoro. Le due piastre affiancate permettono allo chef di ottenere simultaneamente e in brevissimo tempo due passaggi di temperatura caldo-freddo e freddo-caldo: questo sia in occasione di show cooking, sia nella quotidianità del backstage in cucina. Un metodo che permette la conservazione dei valori nutrizionali dei cibi, ideale per ristoranti di altissimo livello, catering e chef che vogliono gestire una cucina d'avanguardia.

**TEPP-TWIN** is an appliance composed by two independent plates placed side by side allowing to cook up to +240 °C (on the left) and fast cool down up to -38 °C (on the right). Unique and versatile, offering to the most creative chefs the possibility to invent and create recipes from appetizers up to desserts, passing through the main courses, without using other resources. The result is always a harmony of flavors and colors enhancing nutritional properties. The use of the cold plate (down to -38 °C) facilitates the microbial reduction and enhances the colors fixing and the food nutritional properties. The transition from the cold plate to the hot one activates the thermal shock enhancing the food color and texture. The dish is then finished on one of the two plates, depending on the desired recipe.

TEPP-TWIN is an electric appliance equipped with an independent and integrated extraction system, filtering through one viledon and one activated carbon filters, with unducted outlet in the environment.

The main advantage of TEPP-TWIN is the ability to cook and quickly cool food, thanks to the presence of one single worktop. The two side-by-side plates allow the chef to get simultaneously and in a short time two hot-cold and cold-hot temperature changes, both during show cooking, and in the everyday backstage life in the kitchen. A method that allows for the preservation of the nutritional value of food, ideal for high-level restaurants, caterers and chefs who want to manage avant-garde cuisine.





# **FLEXIBLE COOKING**



# Filchef



# Filchef

**FILCHEF**  
FILCHEF





## Filchef

Un nuovo concetto di flexible cooking che unisce la qualità della cottura professionale al design.

Adatta al settore Luxury Home, catering o eventi, FILCHEF viene realizzata su misura e progettata per location outdoors.

A new flexible cooking concept that combines professional cooking's quality with design.

Suitable for the Luxury Home sector, catering and events, FILCHEF is realized to measure and designed for outdoors locations.

Model	 (A x B x C) mm	kW	€
<b>FIL1600001</b>	1600x700x850h	 28,0	<b>9.885,00</b>

### VERSIONE COLORATA SU RICHIESTA / COLORED VERSION ON REQUEST

Blocco cottura mm.1600x700x850h. interamente realizzata in acciaio inox AISI 304, con:

- Piano monoblocco in acciaio inox AISI 304 18/10 spessore mm.2,0
- Piano cottura con n.2 bruciatori fuochi aperti in ghisa cromati (n.1 doppia corona 7,5kW e n.1 monocorona 4,5 kW), con termocoppia e fiamma pilota. Accensione fuochi manuale. Bacinella bifuoco raccogli goccia estraibile prof. mm. 22 per una facile manutenzione e pulizia. Griglie monofuoco smaltate nera lucida o raf.
- N.1 piano di lavoro al centro con n.1 cassetto porta utensili sottostante.
- N. 1 griglia a gas pietra lavica mm.800x700 (kW.16,0) con griglia inox a V, regolabile in altezza, per la raccolta dei grassi di cottura oppure griglia in tondino per cottura pesce (su richiesta). Canalina frontale con foro di scarico e GN 1/3 h.65 mm posizionata nel vano inferiore. Alzatina paraspruzzi su tre lati. Bruciatori gas a due tubi fiamma ad alto rendimento con rubinetto valvolato, con regolazione temperatura max-min, termocoppia e accensione piezoelettrica
- Coperchio in acciaio inox AISI 304
- Vano inferiore chiuso con antine.
- Manopole in materiale atermico.
- N.4 ruote piroettanti in nylon-poliuretano d.mm.100 di cui n. 2 con freno.

Cooking unit mm.1600x700x850h, Structure in AISI 304 stainless steel scotch bright, with:

- Work top in AISI 304 stainless steel scotch brite mm. 2,0 thick.
- N.2 Chromium-plated cast iron open burners (n.1 double crowned of kW 7,5 and n.1 single crowned of kW 4,5) with thermocouple and pilot flame. Manual ignition. Printed removable drip pans for 2 burners for an easier maintenance and cleaning, depth mm. 22. Bright porcelain enameled or raf cast iron grid for one top burner.
- N.1 working top in the with underneath n.1 drawer for tools.
- N.1 gas lava rock grill mm.800x700 (kW.16,0 with stainless steel grid for meat with a "V" shape to drain off fat or steel rod cooking grid for fish (on request). Front grease runner with hole-drain and fat collection GN 1/3 h. 65 mm positioned in the lower compartment . Splashback on three sides. High efficiency gas burners with two flames, gas safety tap, with temperature setting min./max., thermocouple and piezoelectric ignition. Knobs made of heat-resistant material. AISI 304 stainless steel adjustable feet
- AISI 304 stainless steel scotch brite lid
- Model on cabinet closed with n. 4 doors.
- N.4 wheels d.mm.100 (n.2 with breaks)
- Manufactured exclusively to measure

# СООКТЕРР





# CCOOKTEP

Le nuove isole aspiranti **CCOOKTEP** sono ideali per servizi di ristorazione e catering in assenza di impianti di aspirazione tradizionali con canna fumaria.

The new **CCOOKTEP** extraction islands are ideal for restaurant and catering services when traditional aspiration systems with an exhaust pipe are not available.

Model	 (A x B x C) mm	kW		€
CCOOKTEP800	1350x750x1800h	⚡ 11,4	aspirazione attraverso canale sinistro/ aspiration through left	20.929,00
CCOOKTEP900	1350x750x1800h	⚡ 11,4	aspirazione attraverso canale destro/ aspiration through right	20.929,00

- Interamente realizzate in acciaio inox AISI 304
- Filtrazione aria attraverso filtri in rete inox (efficienza G2), filtro ondulato sintetico (efficienza G4) e filtro a carboni attivi per abbattimento parziale di fumi e odori
- Aspiratore portata m3/h. 1.500 - kW 0,55 – AC230V 50Hz
- Aspirazione attraverso canale sinistro (CCOOKTEP800) o destro (CCOOKTEP900).
- Teppanyaky elettrica DROP-IN mm.1000x600 con n.2 zone cottura con blocchi resistenze in acciaio ad alto rendimento potenza kW 5,4 cadauno 3Nac400V 50Hz, termostato di lavoro, termostato di sicurezza. Piastra liscia in acciaio speciale al cromo duro lucido) spessore mm.15, ad alta conducibilità termica, facilmente pulibile, a basso livello di irraggiamento, con un notevole risparmio energetico. Piastra liscia con canalina perimetrale con n.1 foro di scarico liquidi, n.1 capiente cassetto raccolta residui di cottura .
- n.4 ruote (n.2 con freno)
- Costruzione su misura

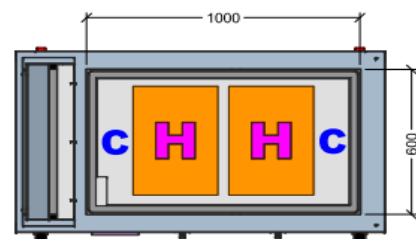

- Entirely realized in stainless steel AISI 304
- Air filtration through stainless steel mesh filters (G2 efficiency), synthetic corrugated filter (G4 efficiency) and activated carbon filters for partial fumes and odors abatement
- Aspiration capacity m3/h 1.500 - kW 0,55 – AC230V 50Hz
- Aspiration through left (CCOOKTEP800) or right (CCOOKTEP900) channel
- Electric Teppanyaky DROP-IN version, mm.1000x600 with 2 cooking zones with high efficiency steel resistance blocks, power 5.4 kW each 3Nac400V 50Hz, working thermostat, safety thermostat. Smooth plate in special polished hard chrome steel, mm. 15 thick, with high thermal conductivity, easy to clean, with a low level of irradiation and a significant energy saving. Smooth plate with perimeter channel with nr. 1 drain hole, nr. 1 large drawer to collect cooking residues
- Nr. 4 wheels (Nr. 2 with brake)
- Customisable upon request

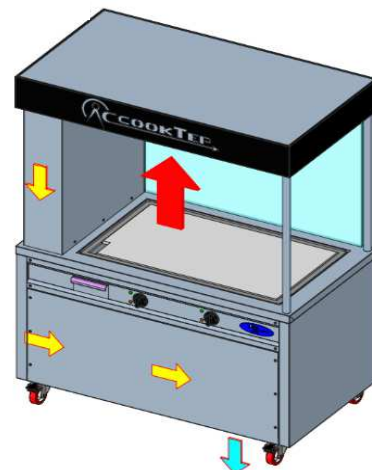

# CCOOKAIR



La nuova isola aspirante CCOOKAIR è ideale per tutte le attività di ristorazione e catering esercitate in ambienti privi di impianti di aspirazione e canna fumaria con espulsione esterna.

**CCOOKAIR2100** è dotata di **CCDEP8001**, sistema innovativo di trattamento dei fumi e degli odori derivanti dalla cottura dei cibi, brevettato, in grado di garantire un reale ed efficace abbattimento di fumi al 98% e odori al 90-95%. È in grado di soddisfare i requisiti delle normative in vigore e di garantire un ambiente di lavoro sicuro e confortevole.

Ideale per l'utilizzo con BroilyGrill.

Un sistema innovativo, che combina diverse tecnologie per ottenere un'elevata efficienza di trattamento che si avvicina quasi alla perfezione.

CCOOKAIR2100 è interamente realizzata in acciaio inox AISI 304, con n.4 ruote (n.2 con freno) per una facile movimentazione, piano di appoggio per elementi di cottura, impianto di aspirazione composto da :

- generatore di ozono che trasforma i grassi in polvere ed elimina completamente gli odori, posizionato nella parte superiore della cappa (incluso nel prezzo)
- DEPURATORE CCDEP8001, posizionato nella base inferiore della CCOOKAIR2100, con 4 stadi diversi di filtrazione, sempre più fini, in modo da catturare progressivamente le particelle di diverse dimensioni. In sequenza:
  1. filtri a labirinto posizionati nella cappa superiore
  2. filtri per alte temperature (efficienza G5) per trattenere polvere medio grossa
  3. filtri elettrostatici per abbattimento di fumi al 98% e odori al 90%,
  4. filtri a tasche rigide arricchito di carbone attivo (efficienza G7) per eliminare il residuo delle particelle odorose.
- I filtri offrono una certa resistenza al passaggio dell'aria, per cui essa deve venir forzata attraverso di essi con aspiratore ad alto rendimento portata m<sup>3</sup>/h 3100 - kW 2,2 380V 5060Hz, con espulsione superiore.

**CCOOKAIR2100 è conforme alle seguenti Normative UNI 7129:2008 (e successive modifiche) - UNI 8723:2008 - UNI 13779:2008 (e successive modifiche)**

#### **PUO' ESSERE UTILIZZATA IN AMBIENTI SENZA CANNA FUMARIA UTILIZZANDO APPARECCHI DI COTTURA ELETTRICI.**

In caso di interesse forniremo relazione tecnica dettagliata.

The new CCOOKAIR extraction island is ideal for all restaurant and catering activities carried out in rooms without suction systems and flues with external exhaust.

The **CCOOKAIR2100** is equipped with **CCDEP8001**, an innovative patented system for treating fumes and odours resulting from cooking, which guarantees a real and effective elimination of fumes to 98% and odours to 90-95%.

It meets the requirements of current regulations and provides a safe and comfortable working environment.

Ideal for use with BroilyGrill.

An innovative system, combining several technologies to achieve a high treatment efficiency that comes close to perfection.

CCOOKAIR2100 is made entirely of AISI 304 stainless steel, with 4 wheels (2 with brakes) for easy handling, support surface for cooking elements, suction system consisting of :

- ozone generator that transforms grease into powder and completely eliminates odours, located in the upper part of the hood (included in the price)
- PURIFIER CCDEP8001, installed in the lower base of the CCOOKAIR2100, with 4 different stages of filtration, progressively finer and finer, to gradually capture particles of different sizes. In sequence:
  1. labyrinth filters positioned in the upper hood
  2. high temperature filters (G5 efficiency) to retain medium to coarse dust
  3. electrostatic filters for 98% smoke and 90% odour elimination,
  4. rigid pocket filters enriched with activated carbon (G7 efficiency) to remove residual odorous particles.
- the filters offer a certain resistance to the passage of air, which is why air must be forced through them with a high-efficiency extractor fan flow rate m<sup>3</sup>/h 3100 - kW 2.2 380V 5060Hz, with top ejection.

**CCOOKAIR2100 complies with the following Standards UNI 7129:2008 (and subsequent amendments) - UNI 8723:2008 - UNI 13779:2008 (and subsequent amendments)**

#### **IT CAN BE USED IN ENVIRONMENTS WITHOUT A FLUE USING ELECTRIC COOKING APPLIANCES.**

If interested, we will provide a detailed technical report.

Model	 (A x B x C) mm	kW	€
-------	---	----	---

GENERATORE OZONO /  
OZONE GENERATOR



CCOOKAIR2100	2100x850x2000h	⚡2,2	3Nac400V 50/60 Hz 16A	27.582,00
--------------	----------------	------	-----------------------	-----------

CCOOKAIR

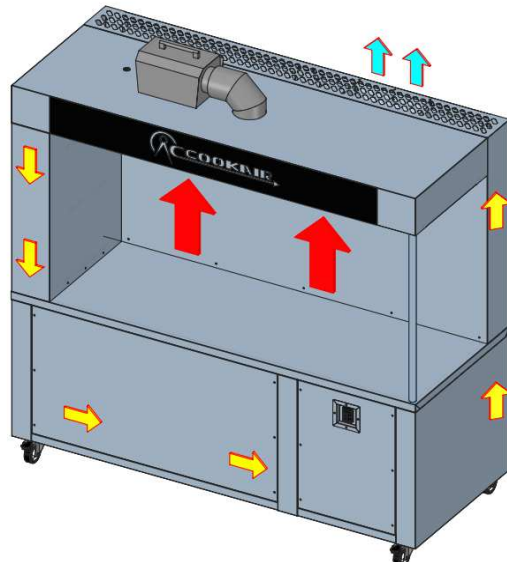





Casta 1 - Via F.lli Lumière, 11  
Casta 2 - Via F.lli Lumière, 30  
(Z.I. Villa Selva) - 47122 Forlì (FC) Italy  
Tel. +39 0543 782920 - Fax +39 0543 782925

**[www.casta.com](http://www.casta.com)**